

All rights reserved

This book is protected by copyright and all rights are reserved. No part of it may be reproduced or transmitted by any means or in any form without prior written consent from Gateway 2000.

The information in this manual has been carefully checked and is believed to be accurate. However, Gateway 2000 assumes no responsibility for any inaccuracies that may be contained in this manual. In no event will Gateway 2000 be liable for direct, indirect, special, incidental, or consequential damages resulting from any defect or omission in this manual, even if advised of the possibility of such damages.

In the interest of continued product development, Gateway 2000 reserves the right to make improvements in this manual and the products it describes at any time, without notice or obligation.

Trademark acknowledgments

AnyKey, cow spot motif, CrystalScan, Gateway 2000, HandBook, RIDE, Store-On-A-Disc, TelePath, stylized "G" design, and motto "You've got a friend in the business" are registered trademarks of Gateway 2000. ColorBook, EZ Pad, EZ Point, Family PC, Gateway 2000 Duoline, Gateway 2000 Solo, GW2K, Liberty, and Vivitron are trademarks of Gateway 2000. Intel is a registered trademark of Intel Corporation. Microsoft, MS, MS-DOS, and Windows are trademarks or registered trademarks of Microsoft Corporation. All other product names mentioned herein are used for identification purposes only, and may be the trademarks or registered trademarks of their respective companies.

FCC statement

This device complies with part 15 of the FCC Rules. Operation is subject to the following two conditions: (1) This device may not cause harmful interference, and (2) This device must accept any interference received, including interference that may cause undesired operation.

This equipment has been tested and found to comply with the limits for a Class B digital device pursuant to Part 15 of the FCC Rules. These limits are designed to provide reasonable protection against harmful interference in a residential installation. This equipment generates, uses, and can radiate radio frequency energy and, if not installed and used in accordance with the instructions, may cause harmful interference to radio communications. However, there is no guarantee that interference will not occur in a particular installation. If this equipment does cause harmful interference to radio or television reception, which can be determined by turning the equipment off and on, the user is encouraged to try to correct the interference by one of more of the following measures:

- Reorient or relocate the receiving antenna
- Increase the separation between the equipment and receiver
- Connect the equipment into an outlet on a circuit different from that to which the receiver is connected
- Consult Gateway 2000 or an experienced radio/TV technician for help.

Caution: Changes or modifications not expressly approved by the party responsible for compliance could void the user's authority to operate the equipment.

To meet FCC requirements, shielded cables and power cords are required to connect this device to a personal computer or other Class B certified device.

Cautions and warnings

CAUTION: The internal lithium ion battery used in this device can present a danger of explosion or fire if the battery is incorrectly replaced. Do not disassemble, incinerate, or heat above 60°C (140°F). Replace only with the same or equivalent type recommended by the manufacturer. Discard used batteries promptly in accordance with battery manufacturer's directions, and keep them away from children.

ATTENTION: Il y a danger d'explosion s'il y a remplacement incorrect de la batterie. Remplacer uniquement avec une batterie du même type ou d'un type recommandé par le constructeur. Mettre rebut les batteries usagées conformément aux instructions du fabricant.

CAUTION: This equipment uses a grounded power cable. Do not attempt to defeat the grounding prong. Do not remove the grounding prong. If you use a three-prong adapter, be sure to connect the ground wire to a good ground.

Replace the cord if it becomes damaged. U.S. and Canadian replacement cords must be UL-approved (CSA certified in Canada) type SPT-2, 18 AWG, 2-conductor cord with permanently attached NEMA type 5-15P plug at one end and a permanently attached connector body on the other. Cord length may not exceed 15 feet. Outside the U.S. and Canada the cord must be rated for at least 250VAC at 10 amps, and must indicate international safety agency approval. The plug must be a type appropriate for the country of use.

Obtain replacement cords at an authorized service center. The replacement must be of the same type and voltage rating as the original cord.

WARNING: Always plug the cord into an easily accessible outlet near the equipment so that unplugging the cord is an easy way to shut off power.

Do not attempt to disassemble the AC adapter. The AC adapter has no user-replaceable or -serviceable parts inside. The AC adapter has dangerous voltages that can cause serious personal injury or death. Return defective AC adapters to Gateway 2000.

The AC adapter is intended for use with a computer. Both must meet EN 60950.

Sicherheitshinweise

VORSICHT: Explosionsgefahr bei unsachgemäßem Batteriewechsel. Originalbatterien nur durch gleiche oder vom Hersteller empfohlene Batterien ersetzen. Gebrauchte Batterien an Gateway 2000 zurücksenden.

CAUTION: DO NOT OPEN. NO USER SERVICEABLE PARTS INSIDE
ATTENTION: NE OUVRIER PAS. PARTIS RÉPARABLES UNIQUEMENT À L'USINE
VORSICHT: NICHT ÖFFNEN. ENTHÄLT KEINE VOM BENUTZER ZU WARTENDEN BESTANDTEILE

VORSICHT: Diese Ausrüstung verwendet ein geerdetes Netzkabel. Den Erdungskontakt unter keinen Umständen umgehen oder entfernen. Bei Verwendung eines dreipoligen Adapters den Erdungsdraht stets an geprüften Erdungskontakt anschließen.

Beschädigte Kabel ersetzen. Ersatzkabel in den USA und Kanada müssen folgende Bedingungen erfüllen: UL-anerkannter (in Kanada CSA-zertifizierter) SPT-2 Typ, 18 AWG, 2-Leiter-Kabel mit fest installiertem NEMA-Typ-5-15P-Stecker und fest installierter Anschlußdose am anderen Ende, max. 4,57 m Länge. Außerhalb der USA und Kanada gelten folgende Bedingungen: Kabel für mindestens 250 V Wechselstrom bei 10 A, anerkannt durch internationale Sicherheitsbehörde, landesspezifischer Stecker.

Ersatzkabel nur im Fachhandel erwerben. Nur Ersatzkabel des gleichen Typs und für die gleiche Spannung (Voltzahl) wie das Originalkabel verwenden.

ACHTUNG: Netzkabel stets in eine gut zugängliche Steckdose nahe der Ausrüstung einstecken, um durch einfaches Ziehen des Steckers jederzeit die Stromversorgung unterbrechen zu können.

Den Adapter unter keinen Umständen auseinanderbauen. Der Adapter enthält keine vom Benutzer zu ersetzenden oder zu wartenden Bestandteile. Die Spannung im Adapter kann beim Auseinanderbau zu Verletzungen oder Tod führen. Beschädigte Adapter an Gateway 2000 zurücksenden.

Der Adapter ist für den Gebrauch mit einem Computer bestimmt. Adapter und Computer müssen die Norm EN 60950 erfüllen.

Environmental considerations

Your Gateway 2000 Liberty has been engineered to provide many years of reliable service. However, you should give it the same reasonable care and protection that you would any other electronic equipment. Damage caused by dropping the Gateway 2000 Liberty, impact with another object, or immersion in liquids is not covered by the warranty. Never expose the Gateway 2000 Liberty to rain, snow, or moisture. Avoid locations with high levels of dirt, dust, or smoke.

Colophon

This manual was created electronically with a Gateway 2000 486DX2/66 computer system, MS-DOS 6.22, Windows for Workgroups 3.11, Page-Maker 5.0, CorelDraw 5.0, Adobe Type Manager 3.01, and Adobe Postscript fonts including Stone Sans, Eras Book, Myriad Headline, Insignia, Gill sans, and Giddyup Thangs.



In our effort to use nature's resources efficiently and wisely, Gateway 2000 prints all manuals on recycled papers that meet the minimum requirements established by the Federal EPA in its guidelines for recycled paper products.

Printed in the United States of America

Thank you for purchasing this Factory Service Manual CD/DVD from servicemanuals4u.com.

Please check out our eBay auctions for more great deals on Factory Service Manuals:

servicemanuals4u

Contents

- 3 If you don't read manuals!**
- 4 Welcome!**
- 5 Specs**
- 6 Where it is, what it does**
 - 6 Outside
 - 7 Underside
 - 8 Inside
 - 9 Attachments
- 10 Using the Gateway 2000 Liberty**
 - 10 Your first time . . .
 - 10 Operating modes
 - 10 Restart methods
- 1 The keyboard**
 - 1 Windows 95 keys
 - 1 Double-use keys
 - 1 Keys with Fn
 - 1 Numeric keypad
 - 12 Cursor-movement keys
 - 12 The EZ Point
- 12 Using Windows**
 - 12 Customizing Windows
 - 13 The Windows Control Panel
 - 13 The Windows File Manager
 - 13 What's "File, Run"?
 - 14 Some important programs
 - 14 BattStat
 - 15 Card View
 - 15 Card Power
 - 15 Exiting Windows
- 16 Talking to the outside world**
 - 16 The floppy disk drive
 - 16 The serial port
 - 16 The IR port
 - 17 The parallel port
 - 17 Using a modem
- 17 Preventing loss**
- 18 Using the Setup program**
 - 18 Entering and leaving the Setup program
 - 18 Getting around in the Setup menu
- 18 The Setup settings:**
 - 18 Date and time
 - 18 Startup (boot) drive
 - 18 Display
 - 18 Power switch
- 19 The Password menu**
 - 19 If you lose your password. . .
- 19 The Port Assignment menu**
- 19 The Power Management menu**
 - 20 Understanding power management choices
- 21 The Miscellaneous menu**
- 21 The Keyboard menu**
- 22 Using the PCMCIA software**
 - 22 Adding a new PCMCIA device
 - 22 Windows PCMCIA software
 - 23 Card View
 - 23 Card Power
- 24 Adding memory**
 - 24 Installing the memory upgrade
- 25 Troubleshooting**
 - 25 Startup
 - 26 Communications
 - 27 Memory
 - 28 Miscellaneous
- 30 Index**

We avoided using jargon in this book, but a certain amount is inevitable.

If you look in the Gateway 2000 group in Windows, you'll find a dictionary of computer terms and jargon. If you encounter a word in this book that you don't understand, you can look it up there.

If you don't read manuals!

Here are some items that you might not discover for yourself:

- ❑ You can enter the Setup program at any time by pressing **Fn+Esc**. (Do so and take a look around.)
- ❑ You **don't** have to shut down the computer when you plug or unplug something. It supports "hot swapping" at every connector. A possible exception is a network PCMCIA card; some cannot be removed and reinserted without losing the connection. (This is a problem with the network, not the unit.)
- ❑ If you use an external keyboard, you can attach a serial mouse to the serial port and use it at the same time.

If your system has Windows 95:

You can use both a serial mouse and a PS/2 mouse simultaneously.

If your system has Windows for Workgroups:

If you attach a serial mouse, the system detects it automatically. A serial mouse disables the EZ Point while it is connected.

If you connect a PS/2 mouse instead of a keyboard, you can still use the EZ Point with the mouse connected.

- ❑ You get the best battery life if you do these:
 - Fully charge, then discharge the battery (by using it) *twice* when you first get the system.
 - Set Power Management (in the Setup program, Fn+Esc) to **Maximum Battery Life**.
 - Keep the backlight as dim as possible (the top slider next to the screen all the way down).
- ❑ Many installation programs don't work well with power management. When you install an application from a floppy, have the AC adapter connected so the system doesn't enter Suspend mode.
- ❑ Look over the "Some important programs" section starting on [page 14](#).
- ❑ If you want to do file transfers with the IR port, read the section about IR file transfers beginning on [page 16](#).

Welcome!

This little computer . . .



. . . can improve your life!

The Gateway 2000 Liberty was born from the belief that a notebook computer could be small enough to carry anywhere easily and still be able to do whatever you want to use a computer for. We think we made a *real* computer so small and useful that you'll end up taking it everywhere.

In creating this second-generation notebook, we tried to anticipate the needs of *real* users. Everyone at Gateway 2000 involved with the Gateway 2000 Liberty uses notebook or subnotebook computers in both their work and personal lives, so the product you now hold benefits from the accumulated experience of demanding users with hundreds of thousands of hours of use. We've used them in Wall Street board rooms, Alaskan fishing boats, and about everywhere in between.

We hope you agree that the Gateway 2000 Liberty achieves exactly the right balance of size and performance.

For example, we learned that people tend to expect a mouse on the right, so we put the EZ Point at the right edge where you can put your finger on it and we put the mouse buttons in a natural location under your thumb. So you have the advantage of an intuitive pointing device without having to take your hands away from the keyboard!



We also found out that notebooks running Windows 95 or Windows for Workgroups give better battery life if they have more RAM (extra RAM lets Windows do fewer swaps to the power-using hard disk). So all Gateway 2000 Liberty configurations have 8MB standard, and you can triple that if you want to obtain the best possible battery life while running large applications.

Here are some more features you should know about:

- ❑ Crash protection on the road. What do you do if the system files go bad when you don't have the floppy drive handy? Just enter the Setup program and set Emergency boot! See [page 18](#), upper right corner.
- ❑ Hard drive removal safety. Lots of portables let you remove the hard drive, but only the Gateway 2000 Liberty prevents damage or data loss by automatically forcing a suspend when you remove the drive.
- ❑ Better Suspend. You can use your computer right until the battery dies. Then you still have three days to find power before you lose data. If the battery is full, suspend lasts two weeks.
- ❑ Real IR connectivity. IR doesn't do you much good if you have nothing to connect to. We include a connector for your desktop system.
- ❑ Big screen. Not only is the screen a big 10.4 inches, but it supports resolutions up to 1024 x 768 with a virtual desktop! See [pages 14 and 18](#).

If you use Microsoft Works as your word processing, spreadsheet number crunching, and database management tool, and if you frequently off-load your files to your desktop system, you'll probably never outgrow the standard 340MB hard disk, but if you use full-power applications like Microsoft Office Professional, and if the Gateway 2000 Liberty is your main system, you'll appreciate having a 720MB drive.

Whichever Gateway 2000 Liberty you own, use it!

Take notes in meetings. When you meet with the same group in the future, there's nothing like loading the file from the last meeting and checking to see if everybody completed their action items.

Jot down those ideas that come to you at odd moments. You won't have to clutter your memory with lots of random ideas that may or may not turn out useful.

Put that book you're writing on it. You can write when you have spare moments.

Get a modem, download some magazine articles from CompuServe or America Online, and use your Gateway 2000 Liberty as a book.

If your company has a conference room with a large screen monitor or projection panel, you can put your presentation in Power Point, then use the VGA connector to connect to the big screen and *really* hammer home your ideas.

Suppose your associate across the table at a meeting has a Gateway 2000 Liberty. You can use the IR feature to communicate silently with each other.

The Gateway 2000 Liberty is so small that it isn't distracting during a meeting like bigger notebooks (and you can play Solitaire when the meeting gets boring—try that with paper and pencil!). On the other hand everyone may want to admire it—so don't be afraid to show it off!

Specs

(Specs are subject to change without notice or obligation.)

<i>Dimensions</i>	(W × D × H) 10" × 8" × 1.6"	<i>I/O ports</i>	Floppy/EPP/ECP parallel port 16550 serial port PS/2 keyboard/mouse connector video connector IR port	<i>Battery pack</i>	NiMH: 9.6VDC, 1850mAh nickel-metal hydride rechargeable; batteries can be "hot-swapped" without rebooting; Recharges in or out of system, system on or off.
<i>Weight</i>	4.1lbs with Lithium Ion battery; 4.2lbs with NiMH battery	<i>Floppy disk drive</i>	External 1.44MB 3.5-inch drive option		
<i>Keyboard</i>	78 keys, 94% scale; provides same functions as standard 101-key Windows 95 AT keyboard	<i>Hard disk drive</i>	340, 540, or 720MB IDE removable drive, depending on system		Lithium Ion: 10.8VDC rechargeable; batteries can be "hot-swapped" without rebooting; Recharges in or out of system, system on or off.
<i>Screen</i>	Backlit DSTN color LCD; 10.4" diagonal (214.2mm x 161.4mm); 800 x 600 x 256 SVGA resolution; Supports virtual screen to 1024 x 768 0.264mm dot pitch; 20:1 contrast ratio	<i>Accessories</i>	AC adapter, IR (infrared) module for desktop system, NiMH battery, Lithium Ion battery Leather carrying case, External floppy disk drive with cable		Conforms to APM 1.1 Permanent internal Lithium ion battery holds system settings about a day with battery pack removed.
<i>Video</i>	1MB video memory; C&T 65545 controller, VESA local bus with Windows acceleration; Video port supports: 640 x 480 x 16–64K colors 800 x 600 x 16 or 256 colors	<i>PCMCIA options</i>	14.4 Kbp or 28.8 Kbp data/fax modem, twisted pair or thin-net (BNC) Ethernet network, token ring network; other cards available from various sources	<i>Battery life</i>	NiMH: 17.76 watt/hours; lasts 2.5 to over 4 hours in typical usage under any Windows environment; fully charged battery lasts about two weeks in Suspend mode; your mileage may vary.
<i>Mouse/Pointer</i>	EZ Point integrated pointer; PS/2-type connector for external mouse	<i>Operating env.</i>	5–40°C; 20–80% noncondensing relative humidity		Lithium Ion: 28.8 watt/hours; lasts 4.5 to 6 hours in typical usage under any Windows environment.
<i>CPU</i>	Intel SL Enhanced 486DX4-100	<i>Software</i>	Windows 95 or MS-DOS 6.22 and Windows for Workgroups 3.11, on-line system manual, and additional applications software preloaded; master diskettes and manuals included for everything except promotional software packages	<i>Charging cycle</i>	Varies depending on battery condition; full charge usually takes about an hour
<i>Cache</i>	8K in CPU; DX4-100 has additional 256K external cache	<i>AC adapter</i>	Requires 100–240 VAC, 0.3A nominal; adapter powers system and charges battery simultaneously	<i>Certification</i>	FCC Class B, UL, CSA, TUV (approved to IEC950/EN60950), CE, VCCI
<i>CPU speed</i>	100MHz				
<i>BIOS</i>	128K; includes configuration utility with password security and power management				
<i>RAM type</i>	70ns 3.3V low power DRAM				
<i>RAM capacity</i>	8MB on board, 4, 8, and 16MB modules available				
<i>Expansion slots</i>	Two PCMCIA Type II; stacked to make a Type III slot; supports hot-swapping of most cards when system is in use				

Where it is, what it does -- Outside

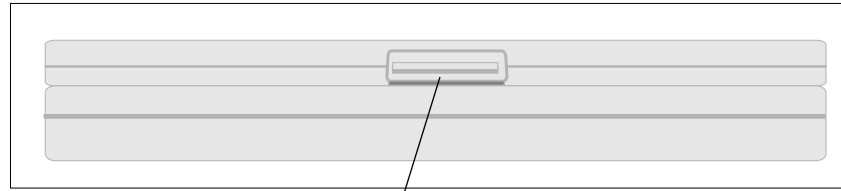

Front. (Shown closed) press the button to unlatch the lid while you open it.

Power switch. Slide it forward to power unit on or off. This switch functions **only** when the unit is open or has a keyboard and monitor attached.

Left side.

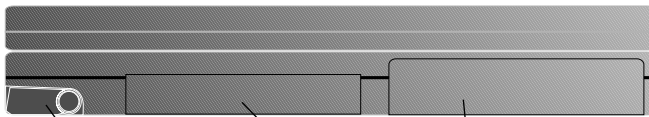

Flip-out foot. Flip it out to tilt the unit for more comfort.

Hard disk drive. See next page.

Battery pack. See next page.



Right side.

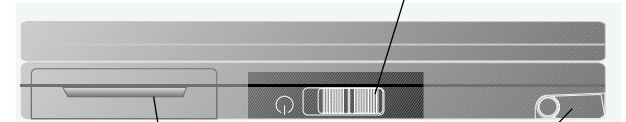

PCMCIA door. Flip it down and slide into the unit. See page 9.

Flip-out foot. Flip it out to tilt the unit for more comfort.

Back.

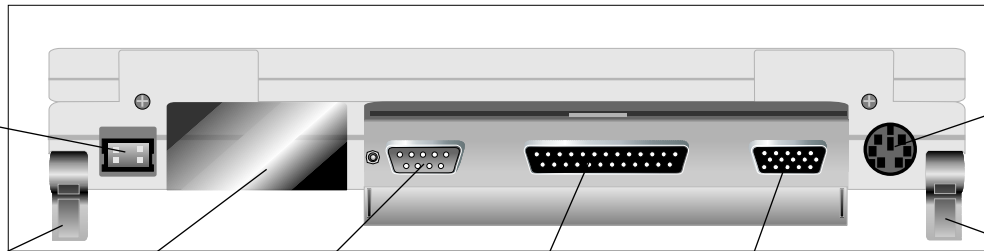

AC adapter. Keyed to fit only one way.

Flip-out foot. Shown flipped out. One on the other end, too.

IR connector. Functions like a serial port (COM2).

Serial port. Functions like a serial port (COM1).

Parallel port. Plug the floppy drive or any parallel device here.

VGA port. Connect any standard monitor here.

PS/2 connector. Connect a mouse or keyboard here.

Flip-out foot. Shown flipped out. One on the other end, too.

Underside

These pictures show the underside of the unit with the hinge at the top.

Memory compartment. Shown with the cover off. Don't open unless you are adding memory. Follow the directions elsewhere in this manual or the instructions that come with the memory module.

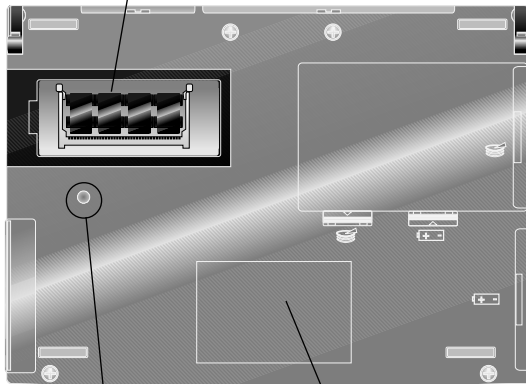

Reset switch. Press with a pen, toothpick or unbent paper clip. Use this reset when resetting from the keyboard doesn't work.

Information placard. The exact model number of your Gateway 2000 Liberty and its serial number are marked here.

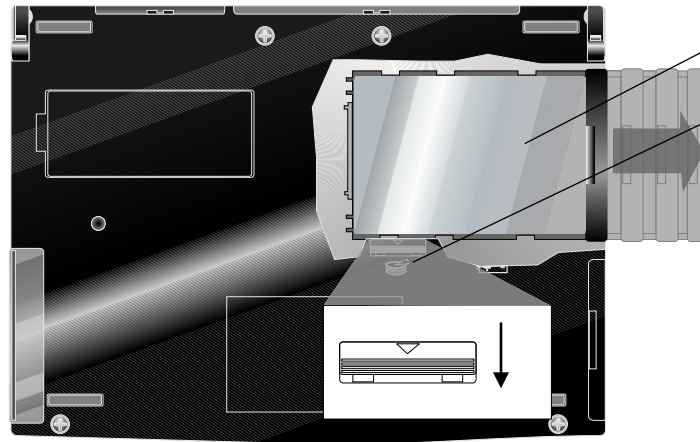

Hard drive (inside).

Hard drive release. System automatically enters Suspend when you slide the release away from the hinge.

When you reinsert a drive, system asks if you inserted the same or a different drive. If you inserted a different drive, press **F1** when prompted. The system reboots and you lose any unsaved data.

If you reinserted the same drive, press **F3** to continue. A warning appears. If you really did reinsert the same drive, press **F3** again.

Do not tell it that the drive is the same one if it isn't.

Both drive and battery pack fit only one way.

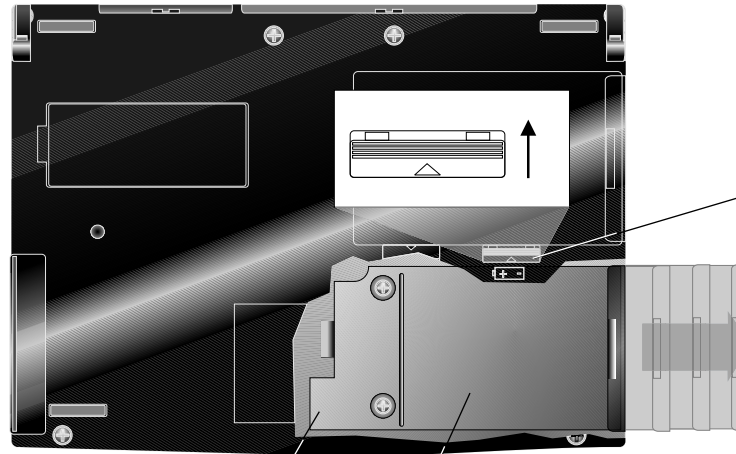

Battery release. System automatically enters Suspend when you slide the release toward the hinge. You can slide the battery out after you release it. You can leave the battery out for about a day without losing data in memory.

When the battery is out of the unit, you can plug the AC adapter into the battery here.

Battery pack.
(inside).

Where it is, what it does

Inside

LCD display. A backlit LCD screen displays 800 x 600 x 256 color SVGA; supports virtual screen up to 1024 x 768 x 256. Clean dust from the screen occasionally with a soft cloth; dampen it VERY slightly to remove fingerprints. Avoid touching the screen; it can scratch, and if you sit on it or hit it hard enough, it'll break.



Contrast and brightness. Slide to operate. Sliding the upper control down all the way saves some power.

EZ Point . Replaces mouse; put your finger on top of the button and push whichever direction you want the pointer to go; the harder you push, the faster the pointer moves. Configurable in Mouse control panel.



How to use the EZ Point . Put any finger on top of the "eraser" and push it the way you want the pointer to go. Your thumb falls naturally over the mouse buttons.

NumLk. If this light is lit, hold down Fn and you get the numbers on the numeric keypad keys. **PadLk.** If this light is lit, hold down Fn and you get the cursor movement functions of the numeric keypad keys.

If both lights are lit, you get the numeric keypad numbers without needing the Fn key.

Shows whether the Caps Lock key is active.

Charger light. Green=fully charged, Orange=charging, Red=loose connection

Mouse buttons. Your thumb goes here.

PCMCIA door .

Battery light. Lit when you're using the battery. Green=OK, Orange=running low, Blinking=very low.

Disk activity lights. Lit when the hard or floppy drive is in use



Where it is, what it does

Attachments

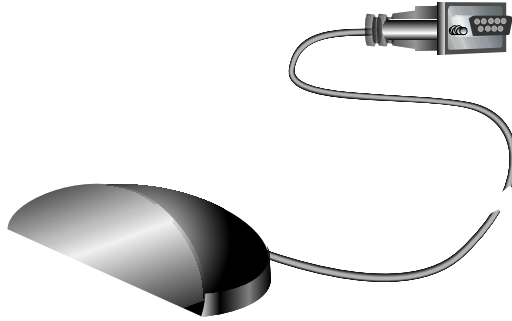

IR module. Attach this to the serial port on a desktop system and put it where the IR port on the back of the Gateway 2000 Liberty can see it. Use it for file transfers. The module you get may look different.

This end connects to the computer or to a battery pack. It fits only one way.

Light is lit whenever adapter is plugged in.

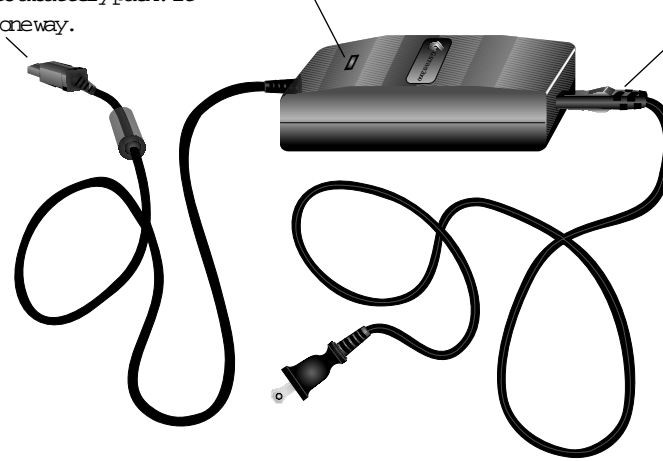

Power cord. Unplugs from the adapter so you can switch to a European-style cord if necessary.

AC adapter. The square plug connects to a Gateway 2000 Liberty battery pack; it can simultaneously power the system and charge the battery in about an hour, or you can charge one battery away from the computer while another one runs the unit.

The AC power cable is removable. As long as you have a power cable with a connector that fits the local wall outlet, you can connect the adapter to any power source between 100 and 240 VAC; the AC adapter adjusts automatically.

PCMCIA slots. Two Type II slots behind door.

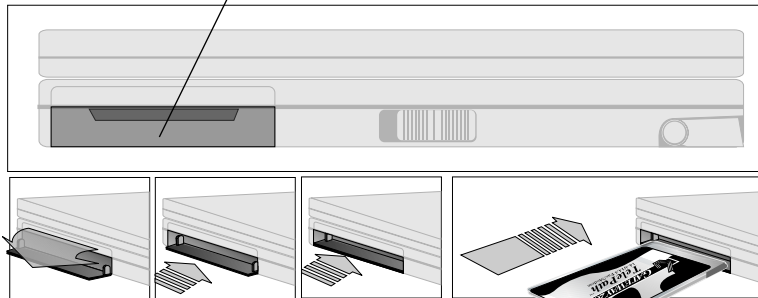

PCMCIA cards. Behind this plastic door is a socket for two Type II or one Type III PCMCIA card.

To open the door, flip the top down and slide it into the unit. Keep it closed when you aren't using it to keep it clean.

Note: Put the PCMCIA card into either socket. The system detects the card automatically in either location.

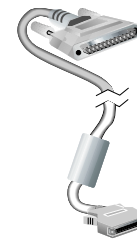

Drive cable. Connects the drive and parallel port. (The port automatically detects that it's not a printer).

Slide button. Ejects diskette.



Using the Gateway 2000 Liberty

Your first time . . .

1. The Battery pack may be dead when we ship the system from the factory, so the first time you use the Gateway 2000 Liberty, connect the AC adapter to the computer. Go ahead and use the system while the adapter charges the battery; it charges just as fast whether you use the system or not, taking about an hour (look for the charger light to change from orange to green). The adapter cannot overcharge the battery.

We recommend that you run the battery all the way down then fully recharge it twice. The battery gauge software will be more accurate, and **battery life will increase greatly.**

2. To open the Gateway 2000 Liberty, hold in the button on the front while you lift the front edge of the cover. Adjust the screen for a comfortable viewing angle.



Cover Latch on front (push in)

3. The power switch is in the middle of the right side. Slide it toward you to switch the Gateway 2000 Liberty on; slide it toward you again to switch it off. You can set this switch to be a true on-off switch or a suspend-resume switch. Refer to the section about the Setup program.

The power switch only operates when the unit is open so you don't accidentally drain the battery. However there's an exception to this: if you connect an external keyboard and a monitor, you can use the switch to power up the system without opening it.

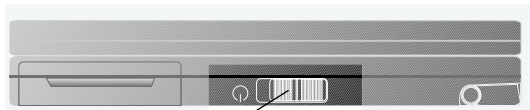

Power switch on right side (slide toward you).

4. Watch the screen. You'll either see your Windows operating system immediately, or assorted messages as the system starts up and then loads Windows. If the screen is dim, adjust the contrast and brightness controls.

That's it—your Gateway 2000 Liberty is ready to use!

Operating modes

- ❑ **On (normal operation):** We don't need to explain this, do we?
- ❑ **Standby:** If you stop using the keyboard and mouse for a while, the screen goes blank, the hard disk drive spins down, and the leftmost LED is lit. This is Standby mode. Press a key to resume normal operation. After about a minute of inactivity, the Gateway 2000 Liberty automatically goes from Standby into Suspend mode.
- ❑ **Suspend:** When you close the lid (if so configured), slide the power switch, or just wait long enough, the Gateway 2000 Liberty switches to Suspend mode. Suspend mode uses almost no power, but it keeps your work right where you left off for up to three weeks, saving you the inconvenience of rebooting when you are ready to use the Gateway 2000 Liberty again.

The computer also suspends when you move the switch that releases the hard drive or the battery.

If the serial port is active, the unit does not suspend even if you shut the lid. This protects file transfers. But it also means you should close (not just minimize) the IR file transfer software when you're not using it.

To leave Suspend mode, slide the power switch. The Gateway 2000 Liberty resumes exactly where you left off. Just to be safe however, we recommend that you always save any data you don't want to lose before you enter Suspend mode. You *don't* need to exit your programs. In most Windows applications, just go to the File menu and select Save.

- ❑ **Total shutdown:** You can set the power switch to completely shut off the computer. (In the Setup program, reached by pressing **Fn+Esc.**) When it is set to ON/OFF, the computer reboots when you switch it on.

Restart methods

You seldom need these, but you should know how:

- ❑ **Ctrl+Alt+Del:** Also known as the three-fingered salute. Press these three keys simultaneously. If it was a typical hang, the computer will restart.
- ❑ **Fn+Alt+Del:** This is the equivalent to pressing the reset button on a desktop system. If the system hangs badly enough, you may need to do this.
- ❑ **Reset switch (on bottom of computer):** If you don't realize the computer has hung, you may keep typing until the keyboard buffer doesn't take any more keystrokes; then **Fn+Alt+Del** won't work. If that happens, or if you feel better doing an actual hardware reset, press the reset button on the bottom of the system with a pen, toothpick, or paper clip. **Nothing happens at first;** then the screen flashes a couple of times. Eventually, a memory test starts and you're back in business.
- ❑ **Super reset:** The reset button doesn't work if the lid is closed. If you ever want to force a reset no matter what, hold in the reset button and flip the power switch.

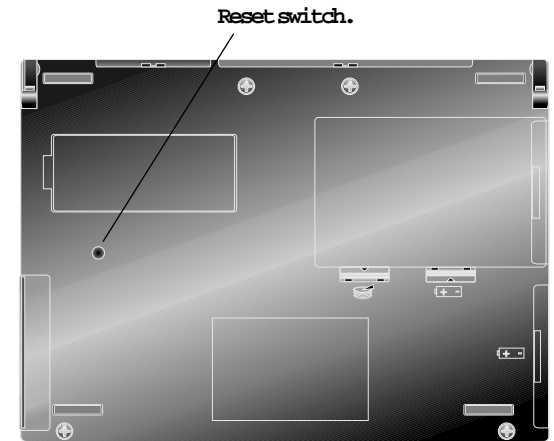

The keyboard

The Gateway 2000 Liberty keyboard is not much different from any other computer keyboard you've used in the past. However, there *are* a few features you should know about.

Windows 95 keys

Two keys have been assigned as Windows 95 shortcut keys. Press the key with the Windows logo to automatically click on the start button in Windows 95. Press the key with the menu symbol to access menus within a Windows 95 application. See your Windows 95 documentation for additional information.

Double-use keys

To save space, some keys have more than one function.

Keys with Fn

- ❑ **Fn:** Hold down the Fn key while you press keys with blue labels to access the functions indicated by the blue labels. If the key has blue labels on top and on the front, you get the function on the front.
- ❑ **Esc/Setup:** Fn+Esc gets you to the Setup program, described later in this manual. You can do this at any time, during any program except, perhaps, when you are transmitting with a modem or network card.
- ❑ **F1/F11 and F2/F12:** Use Fn+F1 or F2 to get F11 or F12, respectively.
- ❑ **F3/monitor:** Fn+F3 rotates among the three display options, LCD panel only, external monitor only, and both.
- ❑ **F4/Pause:** Fn+F4 accesses the Pause function.
- ❑ **F5/Break:** Fn+F5 accesses the Break function.
- ❑ **F6/Prt Sc:** Fn+F6 accesses Print Screen.
- ❑ **F7/Sys Rq:** Fn+F7 accesses System Request.
- ❑ **F9/Num Lk:** Fn+F9 accesses the Num Lock function. Now if you hold down the Fn key while you type a keypad key, you get the function of the blue label on top.
- ❑ **F10/Pad Lk:** Fn+F10 changes the keypad keys to their cursor-movement functions.

Numeric keypad

Some regular keys have extra labels on their tops. These keys can function as a numeric keypad.

To use the numeric keypad:

- ❑ Press **Fn+Num Lk** key so its indicator light is on. Now when you hold down the Fn key, you get what the blue labels on the tops of the keys indicate.
- ❑ If you want the keys to act as a numeric keypad without having to hold down the Fn key, press **Fn+Num Lk** and **Fn+Pad Lk**. (Both lights are lit.)
- ❑ When either or both lights are lit, you can switch these keys to their other functions with combinations of the Shift and Fn keys.

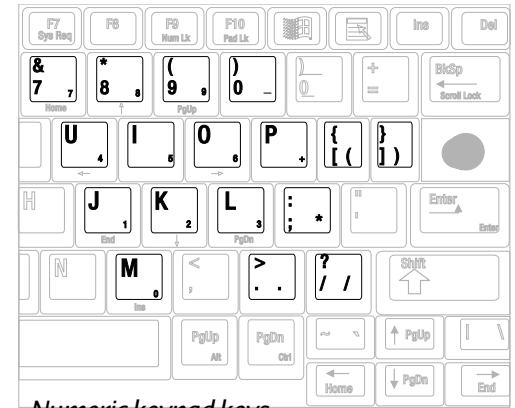

Numeric keypad keys



EZ Point. Operate the EZ Point right-handed, with a finger on the top of the "eraser" (the rubber cover is replaceable) and your thumb on the buttons. Sorry—we don't have a version for lefties!

Important: Never try to remove the keyboard keycaps—you'll break the keyboard.

Mouse buttons (left and right)

Cursor-movement keys

The arrow keys expand to page up, page down, home, and end if you hold down the **Fn** key while you press the appropriate arrow key.

You get the cursor movements normally associated with shifted numeric keypad keys by holding down **Fn** while you press the key.

The EZ Point

The eraser-shaped button just above the Enter key, called the EZ Point, works like a joystick. Put a finger on it and tilt it the direction you want the pointer on the screen to go. The harder you tilt, the faster it moves.

The pointer is that arrow that moves around the screen in Windows when you tilt the EZ Point.

The two long diagonal buttons in the front of the keyboard are the left and right EZ Point "mouse buttons." A lot of first-time users forget about these buttons—they point at something they want, but then press the Enter key. Usually, the wrong thing happens when you do this. Remember that after pointing at something with the EZ Point, you select it by pressing the left mouse button, not Enter!

You can adjust lots of settings for the EZ Point in the Mouse control panel in Windows.

Using Windows

Either Microsoft Windows 95 or Microsoft Windows for Workgroups is pre-installed on your Gateway 2000 Liberty and starts automatically when you reset the unit. If Windows **does not** load automatically, type:

```
win
```

at the C:\> prompt and then press the **Enter** key.

There are not many apparent operating differences between the two Windows operating systems. Most of the differences that will effect you are organizational and visual. We will show screens from both Windows packages; the Windows 95 screen first, followed by the Windows for Workgroups screen. See your Windows 95 documentation for additional information. From now on, unless specified, the reference "Windows" applies to either operating system.

A lot of things are accomplished in Windows by "double-clicking." Double-clicking is when you position the mouse pointer on top of something and then click the left mouse button twice quickly, *without moving the pointer between clicks*.

Windows is an electronic desktop. It's great for organizing files and running programs. Notice that the desktop has several *icons*, small pictures that expand into a window if you double-click on them. A window is a framed rectangular region on your screen.

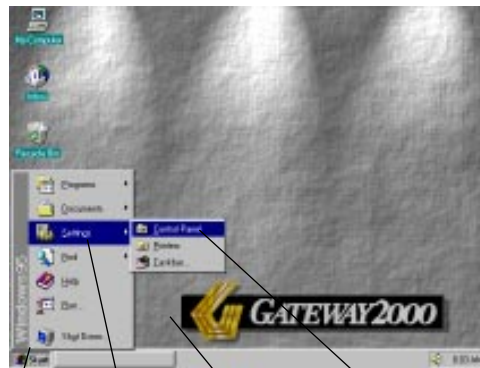

Window Group icon Desktop Program icon

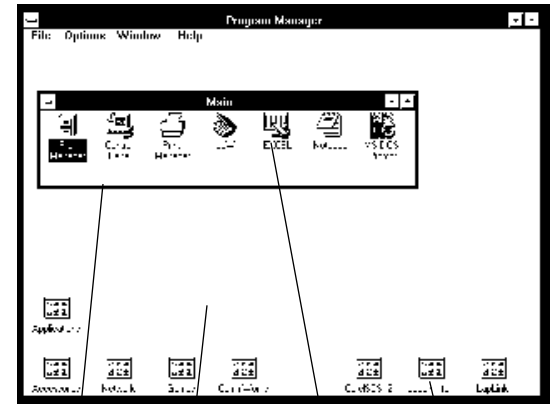

Window Desktop Program icon Group icon

Inside each window are more icons, each standing for a program or a document. To start a program, move the pointer to its icon and double-click on it. If you double-click on an icon that represents a document, you open the document in the program that goes with that document.

One click highlights an icon, but does not expand the window or start a program.

Customizing Windows

Windows organizes your programs into groups. Each group has its own icon. Your Gateway 2000 Liberty is delivered with a lot of pre-installed software, so you'll find several groups that organize your software by type. Double-click on a group icon to see what's in it. You can drag icons (hold down the mouse button while you move the pointer) from one group to another to organize them however you like.

You can resize any window by grabbing an edge with the pointer (it changes into a double arrow) and holding down the mouse button while you move the EZ Point.

This is one of a zillion ways you can customize Windows. For instructions on how to do more customizing, refer to your Windows manual shipped with your Gateway 2000 Liberty.

Some important programs

Some programs are shipped with your Gateway 2000 Liberty that deserve special mention.

In the Control Panel group is a control panel icon labeled **Power**. Double-click on it to open it. Set the power management to Advanced if it is not already there.

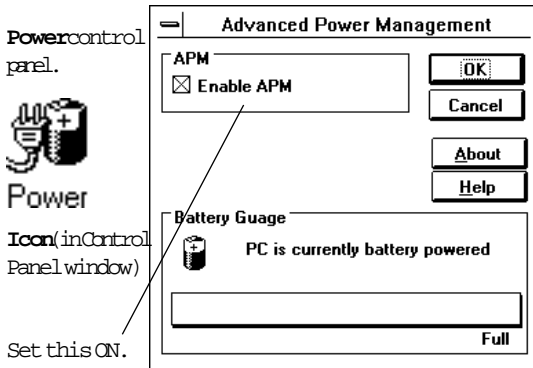
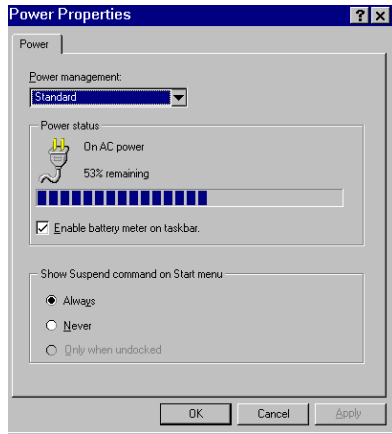

Power control panel.



Power

Icon (in Control Panel window)

Set this ON.

In Windows for Workgroups you also get a video control panel that works in addition to the video setting available in the Setup program. It's called **ChipsCPL**. Choose the settings you want, then restart Windows.



Icon (in control panel window)

You get a virtual desktop with any size over 640 x 480 if the LCD screen is active.

A **virtual desktop** is when you see 800 x 600 pixels at a time, but you can scroll around a larger area by moving the pointer against the edge of the screen.

Display area is equivalent to the Display item in the Setup program or pressing Fn+F3.

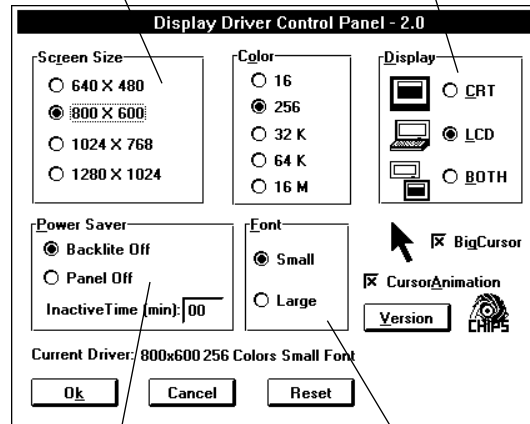

This section is inactive. The internal power management overrides it.

Large fonts are easier to read at high resolutions on a monitor. **Small fonts** take up less space at low resolutions and on the LCD screen.

To locate the window to change the LCD display in Windows 95, click on Settings, Control Panel, and Display.

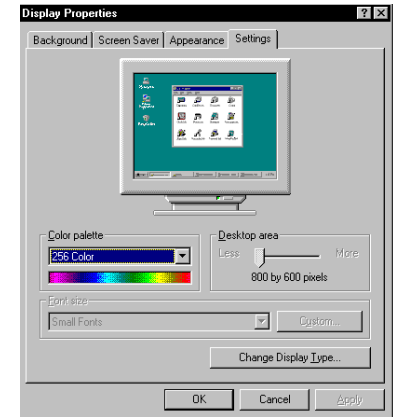

BattStat

To locate battery status information in Windows 95, click on Settings, Control Panel, then Power (see the Power Properties window on this page).



Battstat

An important utility in Windows for Workgroups (it's in the Startup group, so it runs automatically) is called **BattStat**. It shows how much battery you have left. It will be most accurate if you fully charge, then fully run down the battery twice when you first get your system. If you don't want this program to run automatically, drag its icon to another group. To run BattStat (if it's not in the Startup group) double-click on its icon.



BattStat

When BattStat is running, you see an icon in the lower left corner of the screen. If the AC adapter is connected, you see a plug.



BattStat

If you're running with battery power, you see a little battery with a ruler under it. The ruler shows how much power you have left. The icon changes from green to orange to red as battery life decreases.

Minimize button

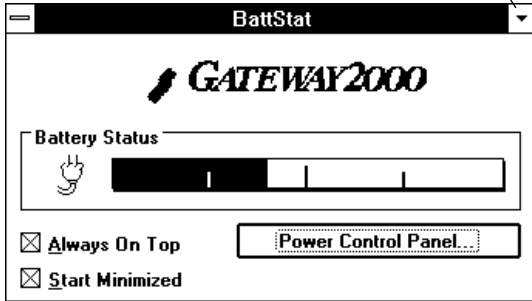

To see an enlarged view of the battery ruler and a few settings, double-click on either icon.

If your system starts up with BattStat large like this, click on the **Start Minimize** button to create the icon.

When you plug or unplug the AC adapter, the icon changes after about half a minute, when the software checks the status of the battery.

If you ever need to reinstall BattStat (only operational in Windows for Workgroups), copy BATTSTAT.EXE from the Cardpower diskette onto the hard drive, then create an icon for it in the Startup group.

Card View



Windows for Workgroups has an excellent and easy to use utility called Card View that shows you what PCMCIA cards you have installed, if any. It is described on [page 23](#).

Card View

Card Power



Windows for Workgroups has a utility called Card Power which prevents problems caused by PCMCIA cards wanting to operate when the system wants to enter Suspend. It is described on [page 23](#).

Card Power

Exiting Windows

For Windows 95:

1. Close any programs that are running.
2. Click on the **Start** button. The Windows 95 menu appears.
3. Click on the **Shut Down...** item at the bottom. You are asked if you want to shut down the computer.
4. Click on **Yes**. A screen appears telling you it is now safe to power down your system.

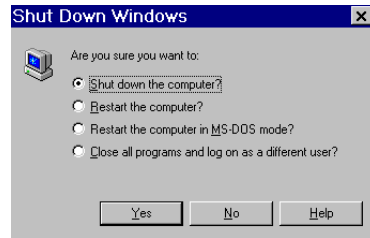

In Windows for Workgroups:

1. Close any programs that are running.
2. Click on the **File** pull-down menu option in the Program Manager window. The File menu appears.
3. Click on the **Exit Windows...** item at the bottom. You are asked if you want to end your Windows session.
4. Click on **OK**. The MS-DOS prompt appears, which looks like this:

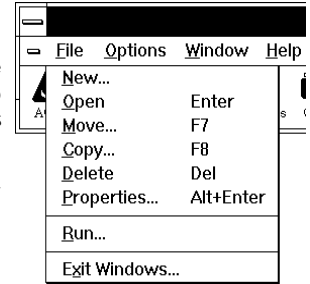

C : \ >

If you are running Windows for Workgroups in conjunction with MS-DOS, when you reset your Gateway 2000 Liberty, it loads DOS. Then the system looks for the CONFIG.SYS and AUTOEXEC.BAT files, and executes the commands it finds in them. For information about these files and how to edit them, refer to the *MS-DOS User's Guide* manual included with your system. If you do something to either of these files that prevents the computer from starting up, you can bypass them by pressing F5 (or step through them by pressing F8) briefly when "Starting MS-DOS..." appears on the screen after a reset. When you reset your Liberty

Talking to the outside world

Computer users need to get info out. Here are some ways:

- ❑ Attach the floppy drive and copy your file onto a floppy; take this floppy disk to another computer.
- ❑ Attach a printer to the parallel port; print your work.
- ❑ Use a serial or parallel cable or the IR connector to connect the Gateway 2000 Liberty to another computer, then use file transfer software to exchange files between the two computers.
- ❑ Use a PCMCIA modem to communicate with another computer over telephone lines or a cellular phone; you can send your work as a data file or fax it to another computer or fax machine.
- ❑ Use an Ethernet card to connect the Gateway 2000 Liberty to your office network.
- ❑ Connect the Gateway 2000 Liberty to an LCD overhead projector panel or video display through the video port.

Printing your work is probably easiest, provided your recipient is satisfied with a paper copy. Exchanging files on a floppy disk is the handiest way to move your actual data; a fax/modem card is a close second.

If you do a lot of exchanging of files between your Gateway 2000 Liberty and another computer, we recommend the TranXit file transfer software and the included IR connector. Infrared communication is a new technology that provides wireless file transfer. It should be more convenient and easier to use than cables. You can use a serial or parallel cable, too. If you make a habit of this sort of exchange, consider connecting to your office network with a PCMCIA Ethernet card—this sort of transfer is unbelievably fast.

The floppy disk drive

Use the floppy disk drive just as you would on any other computer. (Of course, you have to remember to connect it first!) You can connect and remove the drive anytime; you don't have to shut down the system.

Always insert a diskette label side up (up on the drive is the side with the eject switch). Don't remove it when the activity light is lit.

If you have one, you can use the floppy drive from a HandBook⁴⁸⁶. However, you need to use your unit's cable.

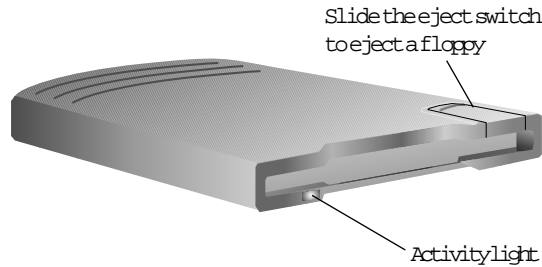

Note: Power management doesn't mix well with many installation programs. When you install an application from a floppy disk, it's best to have the AC adapter connected so the unit doesn't enter Suspend mode.

The serial port

Windows 95 has a direct cable connection option. Refer to your Windows 95 documentation.

If you have a null modem serial cable, you can connect the Gateway 2000 Liberty to another computer through the serial port. You can use Interlnk software (it's part of DOS) to transfer files, or you can use the supplied file transfer software. For information on using Interlnk, go to the DOS prompt, type:

```
help interlnk
```

and press **Enter**. For the supplied file transfer software, follow the directions in its manual.

The serial port behaves like a serial port on any other computer, which means you can also use it to connect a mouse, ham radio TNC, or any other serial device. We configure the port as COM 1 at the factory; you can change it or disable it in the Setup program (Fn+Esc). If these settings are ever changed, press **Fn+Alt+Del** after exiting the Setup program to allow the system to fully integrate the new settings.

The IR port

The infrared connector at the back of the Gateway 2000 Liberty is really another serial port, and you use it exactly as if it were an ordinary serial connector. It has a range of just over a yard, strictly line of sight. For the technically oriented, we should mention that we designed it according to IRDA specifications.

The separate IR module is new technology, so it has a range of only about nine inches. Connect it to a serial port on your desktop system and use it to save yourself from having to rummage around at the back of your system every time you need to transfer files.

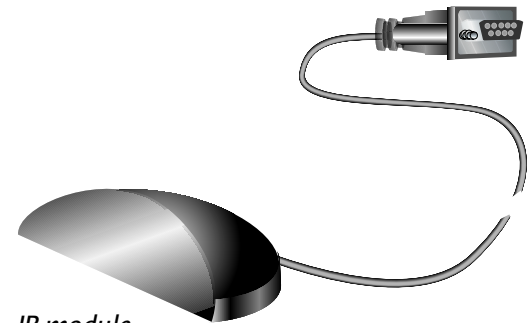

IR module

Most of the information you need for using the IR feature is in the manual that comes with the external IR module. However, here are a few tips:

Attach the IR module to the serial port on the desktop system. Place the business end of the IR module about 6–9 inches from the IR connector on the back of the Gateway 2000 Liberty, and facing it.

On the Gateway 2000 Liberty:

Run TranXit, in the TranXit group. When the program opens, choose the Setup item in the Connection menu, Choose **Infrared** and **Turbo Mode**, then click on **Change Connection Settings**.

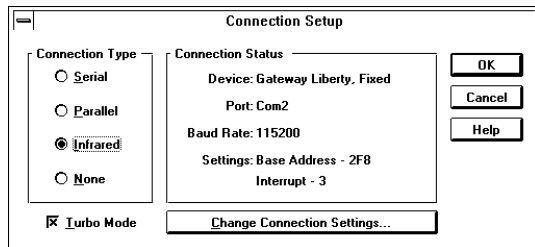

In the Infrared Settings dialog box that appears, choose **Gateway Liberty** for the Model, **Fixed Mode**, **115200** Baud Rate, and whatever COM port, Base I/O address and IRQ is set for the IR port in the Setup program. (To find out, press **Fn+Esc** to enter the Setup program, then choose Port Settings.)

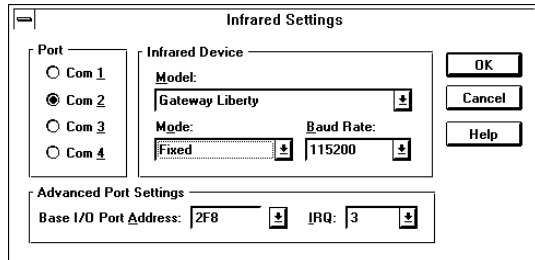

Click on **OK** twice to return to the main TranXit window.

On a desktop system:

If you haven't already, install TranXit on the system. (Use **F11**, **R** to run its setup program.) Open it and choose the same settings as you did on the Gateway 2000 Liberty, **EXCEPT**:

- Choose **Extended Systems** instead of Generic for the Model, and
- Choose the appropriate settings for the serial port the IR module is connected to, which may be different from the Gateway 2000 Liberty's port setting.

Connection is automatic. You are ready to go!

If you ever need to reinstall TranXit on your Gateway 2000 Liberty, insert its diskette into the floppy drive and use **F11**, **R** to run **A:\setup**. You can find detailed reinstallation instructions in the Software Reinstallation Guide.

The parallel port

Parallel ports are most often used for connecting to a printer. You can also connect a parallel data cable for very fast file transfers between the Gateway 2000 Liberty and another computer.

If you connect a scanner or other two-way device to the parallel port, make sure the port is set for bidirectional operation. Bring up the Setup program by holding down the **Fn** key and then pressing the **Esc** key. Then go to the Port Assignment section and set Parallel Port Type to Bi-Directional.

Using a modem

A modem is a practical and versatile way to exchange data and files with fax machines and computers at remote locations. Just plug in a PCMCIA modem, load your communications software, and away you go!

Note: Do not use your PCMCIA modem on a digital phone line! Modems convert digital signals into analog signals that are sent on normal, analog telephone lines. If you attempt to use a line that is already digital, the modem will not work and could blow a fuse and become unusable. If you are in doubt about the type of line you have, ask your phone service supplier.

OK, so it's not always quite that simple. Here are some tips:

- When you plug in the modem, you should hear two beeps that ascend in pitch. This is called the "happy beep." If you don't hear this, somebody may have changed the PCMCIA software we loaded at the factory. Run CONFIG (**does not apply if you have Windows 95**) as described on [page 22](#).

- If not already there, add the following to the end of the EMM386 line in your CONFIG.SYS file (**does not apply if you have Windows 95**), all on the same line, separated by spaces:

```
noems x=c800-cbff x=d000-dfff  
x=ec00-ffff
```

- If the modem *still* doesn't work, see the troubleshooting communications section near the end of this book.



A dependable, fast, and inexpensive PCMCIA modem

Preventing loss

If you are a portable computer user, you probably already know this, but we're going to mention it anyway:

1. Make backup copies of your data files.
2. Store backups in a safe place.
3. Be careful about where you keep your Gateway 2000 Liberty, so it won't get stolen.
4. If you travel, encrypt your data files. If it gets stolen, they still can't get your data.

Strange but true:

Our technicians field phone calls from time to time for support of what turns out to be a stolen computer. Sometimes the culprit actually identifies himself and gives a valid address!

We suggest, therefore, that you notify Gateway 2000 as soon as possible if your Gateway 2000 Liberty is ever lost or stolen. We might be able to help.

Using the Setup program

The Setup program is built right into your Gateway 2000 Liberty, in a part called the ROM BIOS. You use it to make changes that affect the way the Gateway 2000 Liberty works.

Some of the things you can change or adjust with the Setup menu:

- The system password
- Power management settings
- Serial and parallel port assignments
- The system date and time.

Entering and leaving the Setup program

You can enter the Setup program while running most programs (don't run it while you're using the modem). Then:

- To *enter* the Setup program, hold down the **Fn** key and press the **Esc** key. The main menu appears.
- To *leave* the Setup program, press **Esc** one or more times, until a message appears asking if you want to save the changes. Then press **F10** to save and exit, or **Esc** to exit without saving. When changing port settings, press **Fn+Alt+Del** to reboot the system. This allows the system to fully integrate the new settings.

Getting around in the Setup menu

The Setup program shows all the instructions you need to get around in it at the bottom of the screen, but if you need a little help getting started, here are some tips:

- Press an **Arrow** key or the **tab** key to move the highlight from item to item.
- If an item has two or more choices, press the **Spacebar** to rotate the choices until the desired choice is highlighted. (The choices rotate the other way if you press the **BkSp** key.)
- Press **Enter** to move one level deeper into a series of related menus. However, if there is no deeper menu level available from the menu on the screen, pressing **Enter** moves you back *out* one level.
- Press **Esc** to back out one menu level.

The Setup settings:

Date and time

This item is highlighted when you enter the Setup program.

1. Press the **Spacebar** to move to the time editing area.
2. Type the time you want or use the Right and Left Arrow keys to move to a specific number you want to change.
3. Press **Enter** when the time is what you want.
4. Setting the date works the same way. (Use the Arrow to move to the word Date first.)

- HDD**—The Gateway 2000 Liberty starts from the hard drive without trying the floppy drive first. This is the best choice for normal operation.
- EMERGENCY**—The Gateway 2000 Liberty boots from a floppy or from a hidden partition that contains DOS file recovery files, identified as drive C:. The normal drive C: becomes drive D:.

Display

(You can set this with **Fn+F3**, too.) Set this item to enable or disable the video connector at the back of the system. **CRT** means you have to connect a monitor to see anything. It tells the system to allow you to use the power switch with the lid closed. **LCD & CRT** is for when you want to see the screen while you use a monitor. **LCD** disables the video port at the back.

Even though the screen itself shows "only" 800 x 600, you can set it to a virtual screen as large as 1024 x 768 (see page 14). Any attached monitor shows the same virtual screen. However, if you set the Display to **CRT**, the monitor shows the whole desktop.

Power switch

You can set the power switch (on the right side of the unit) to operate as a true on-off switch (in which case you boot up when you start up) or as a suspend-resume switch (you resume right where you left off.) If you start with a full battery, the system lasts about **two** weeks in Sus-

pend mode. **Set this to ON/OFF when you upgrade the memory.**

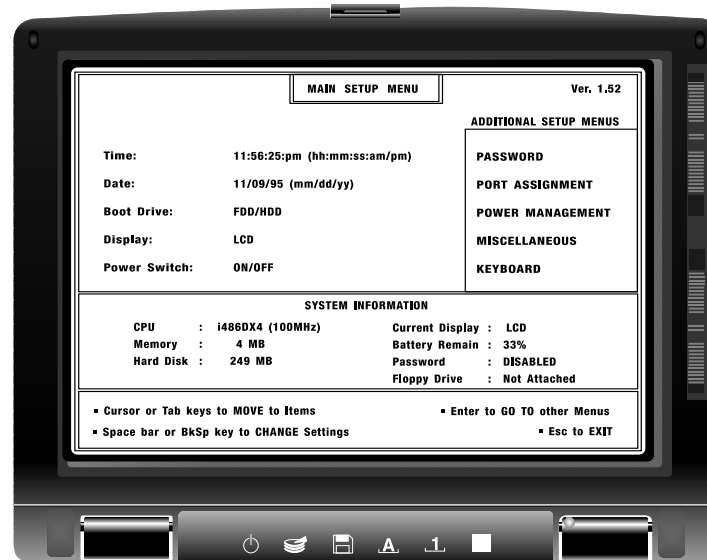

Startup (boot) drive

Highlight the Boot Drive item. Press the **Spacebar** to select one of three choices:

- FDD/HDD**—The Gateway 2000 Liberty looks for a floppy to boot from, and if it doesn't find one, it looks for the hard drive.

The Password menu

Highlight the **PASSWORD** item on the main menu and press **Enter**. Then:

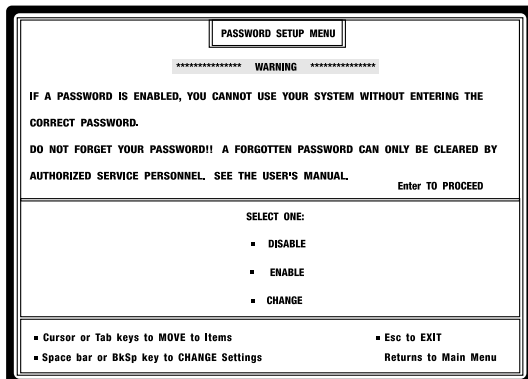

1. If a password is not already set, the **ENABLE** item is highlighted. Press **Enter**.
2. Type a password and press **Enter**. You can enter as many as eight characters. The characters do *not* show up on the screen when you type them. Passwords are case sensitive (upper- and lowercase matters).
3. The system asks you to enter the password again to confirm it. If you enter the same password both times, the message "Password Accepted" appears and you return to the main menu.

From here on, you can't access your Gateway 2000 Liberty without first entering the password.

To change the password:

1. Select the **CHANGE** item in the password menu. A window appears for you to type the old password.
2. Type the old password and press **Enter**. The highlight moves to the **ENTER NEW PASSWORD** field.
3. Type the new password, then press **Enter**. Retype the new password to confirm it. Press **Enter**.

To disable the password:

1. Select the **DISABLE** item on the password menu. A window appears for you to type the old password.
2. Type the password and press **Enter**. You return to the main menu.

If you lose your password. . .

Don't forget your password! The only way to remove a forgotten password and regain access to your Gateway 2000 Liberty is to return it to Gateway 2000.

The Port Assignment menu

Highlight **PORT ASSIGNMENT** on the main menu and press **Enter**.

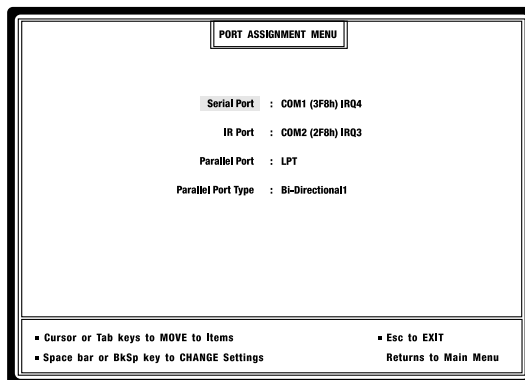

Highlight the item you want to change and press the **spacebar** to change the setting.

The serial and IR ports can be set to COM 1, 2, 3, 4, or Disabled. **COM 1** is the default for the serial connector; **COM 2** is the default for the IR port. You cannot change from the standard memory addresses and IRQs. (Serial devices in the PCMCIA slots default to COM 3 and 4.)

The parallel port is always LPT1, but you may set its type to **AT** (normal) or **Bi-Directional** (ECP/EPP).

The parallel port also functions as a floppy disk drive port. The port automatically switches to that function when you connect the floppy drive.

The Power Management menu

Highlight the **POWER MANAGEMENT** item on the main menu and press **Enter**.

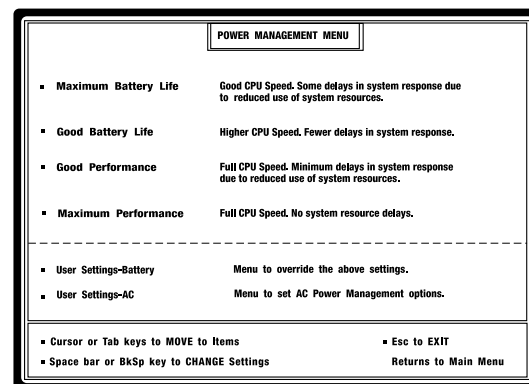

The power management menu has four preset battery power settings that cover most situations. However, you may be able to significantly improve battery life by customizing the settings for your particular needs.

To select a preset setting, highlight the desired setting in the upper section of the screen and press **Enter**. The setting is selected and you return to the main menu. Press **Esc** to exit without keeping any changes.

To customize the power control settings, highlight whichever of the User Settings items you want and press **Enter**. You have two options: one for the settings for when the computer is plugged into the AC adapter, and the other for when the battery is in use.

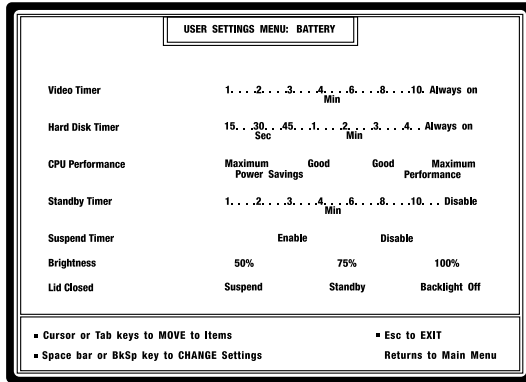

1. Move the highlight to the item you wish to change.
2. Press the **Spacebar** or **BkSp** key until the desired setting is highlighted. Not all choices may be available.
3. Move to the next item. When you finish, press **Enter** or **Esc**. You return to the power management menu. Press **Esc** again to return to the main setup menu.

To disable the Power Manager:

1. Enter the **Control Panel** under Program Manager in Windows.
2. Double-click on the **Power** icon to open the Power Management utility window.
3. Click on the **Enable APM** option once to remove the X and disable the Power Management feature.

Understanding power management choices

- Video Timer:** Sets the number of minutes of inactivity that elapse before the light behind the screen shuts off.
- Hard Disk Timer:** Determines how long the hard disk motor runs before shutting down. The longer it runs, the less often you wait for the hard disk to spin up when you access it. However, running the motor consumes power. If your software makes frequent hard disk accesses, set the spin-down to a longer time. It takes less power to keep the disk going than to spin it up frequently. For accesses that are typically two minutes or more apart, set spin-down to 30 seconds. For accesses less than two minutes apart, set spin-down to one minute.
- CPU Performance:** The faster the computer runs, the more power it consumes.
 - **Maximum Power Savings** runs the CPU at its slowest, power-saving speed at all times.
 - **Good Power Savings** runs the CPU at a moderate speed during use and at its lowest speed during periods of inactivity.
 - **Good Performance** runs the CPU at full speed during use and at its lowest speed during periods of inactivity.
 - **Maximum Performance** runs the CPU at full speed at all times.
- Standby Timer:** Determines how long the keyboard and other input and output must be inactive before it automatically enters Standby mode. Standby shuts off the screen backlight and spins down the hard drive. If you make infrequent entries but want to have the computer ready instantaneously (for example, taking notes at a meeting), set the Standby timer to a longer time.

- Suspend Timer:** Determines whether computer enters Suspend mode automatically. If you set it to Enable, Suspend starts automatically about a minute after Standby begins. Suspend shuts off the screen entirely, spins down the hard drive, saves the contents of memory, and powers down the CPU. Once the system is in Suspend mode, the only way to turn it back on is to press the power switch.
- Brightness:** Determines how much power is consumed by the backlight lamp. Even though it is as efficient as current technology can make it, it consumes a lot of power compared to a computer chip. The dimmer, the less power it uses.
- Lid Closed:** Determines what happens when you shut the lid. *Suspend* saves the most power, but you must press the suspend-resume button to reactivate the computer when you open the lid. Standby only requires you to press a key. *Backlight Off* saves the least power, but allows the computer to continue whatever it is doing, such as printing, performing a large calculation, or downloading. If you have the power switch set to ON/OFF and Lid Closed set to Suspend, you can still use the power switch to **resume** when you first open the lid. The rest of the time it is an on-off switch.

The Miscellaneous menu

To use the Miscellaneous menu, highlight the **MISCELLANEOUS** item on the main menu and press **Enter**.

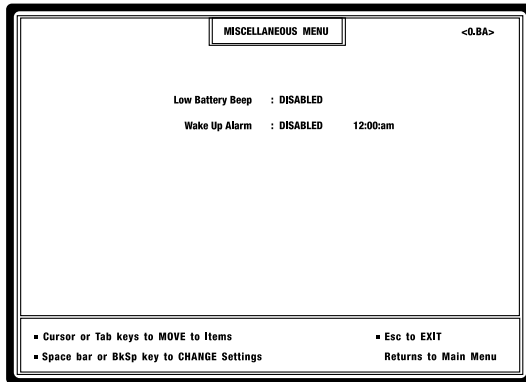

- Low Battery Beep:** When enabled causes the system to beep at you when the battery gets low. This is a good safety measure.
- Wake Up Alarm:** Starts the unit at the time you set and makes it beep. This enables you to use your computer as a very expensive alarm clock, but it is also handy if you need to automatically *transmit* files at a certain time. The unit shuts down automatically after a certain period of inactivity.

The Keyboard menu

To use the Keyboard menu, highlight the **KEYBOARD** item on the main menu and press **Enter**.

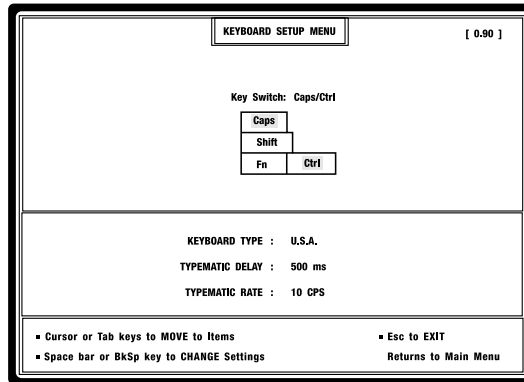

Press the **Spacebar** to exchange the function of the Ctrl and Caps Lock keys. When you have the setting you want, press **Enter** or **Esc**. You return to the main menu, and the Caps Lock and Ctrl keys assume the positions you set. Press the **Up** or **Down Arrow** key to access the lower part of the screen.

- Keyboard Type:** Toggles between USA and Europe.
- Typomatic Delay:** Lets you choose how long you must hold down a key before it begins to repeat.
- Typomatic Rate:** Sets how fast a key types when it is repeating.

Important: Never try to remove the keys from the keyboard—you'll break the keyboard.

Using the PCMCIA software

The advantage of a PCMCIA connector is that you get the power of the latest in technology—you can use and swap little cards that perform any of a wide variety of tasks that make your computing life easier. The disadvantage is that the software that sets up the PCMCIA connector is not yet easy to use.

We did our best to set up your Gateway 2000 Liberty so you will never have to mess with the PCMCIA software. You just plug in your card and go. So, unless you know what you're doing, we strongly recommend that you don't change this software.

If the PCMCIA stops working after you change your system, look at the section on the next page "When you change your system" before you reinstall.

If you ever do need to reinstall the PCMCIA software, you can find detailed instructions in the Software Reinstallation Guide.

Adding a new PCMCIA device

The Windows 95 operating system supports "Plug and Play" hardware. Refer to your Windows 95 documentation for additional information about new hardware installation.

When you first get a new card, try to use it without running third party installation software. If the card works, don't install the third party software. The drivers we install at the factory work with most modem, network, and SRAM cards. If you're installing a network card, use the network driver supplied with the card, but not the PCMCIA software supplied with the card.

The following information applies **only** to Windows for Workgroups users.

To enable drivers for new devices:

1. Use any editor to open the CONFIG.SYS file. You will see several lines that start with "REM DEVICEHIGH."
2. Delete the "REM" from whichever lines apply to your new device. Refer to the following descriptions.

This list explains the PCMCIA lines in the CONFIG.SYS, including the ones that we didn't put "REM" in front of:

- SSCIRRUS.EXE:** Enables the system to communicate with the socket. This file is always necessary!
 - CSALLOC.EXE:** Manages card IRQ, memory, and address. This file is always necessary!
 - ATADRV.EXE:** Generic hard disk driver. Only necessary if you use an ATA hard drive card.
 - MTAA.EXE:** For AMD Type A flash memory card.
 - MTAB.EXE:** For AMD Type B flash memory card.
 - MTI1.EXE:** For Intel Series 1 flash memory card.
 - MTI2P.EXE:** For Intel Series 2 or 2 plus flash memory card.
 - MTATM.EXE:** For an AMTEL flash memory card.
 - MTSRAM.EXE:** Generic RAM card driver. Necessary only if you use an SRAM card.
 - MTDDRV.EXE:** Necessary only if you use a flash or an SRAM card.
 - SSMSFLSH.SYS:** Necessary only if you use a flash card.
 - CARDID.EXE:** Identifies the card to the system. This file is always necessary!
3. Save and exit the editor; reboot.

Your new PCMCIA device should work.

But if the new card still doesn't work, don't install the third party software yet. You may have an unusual software configuration, and you may be able to solve your problem by running CONFIG.EXE. This allows you to modify certain system settings in the PCMCIA software by modifying a file called CARDID.INI. (We run CONFIG.EXE at the factory for the cards we sell, so this is not necessary for cards you buy from us.)

To run CONFIG.EXE:

1. From the CARDSOFT directory, type:

```
config
```

and press **Enter**. Press **Enter** again to get past the title screen.

2. Choose **Edit Configuration** from the File menu. A list of card types appears.
3. Choose the card type that most closely matches your card. A screen appears in which you can set applicable parameters. Choose settings that agree with the information supplied with your card. Avoid choosing settings that conflict with the system's configuration. In other words, if a COM port, IRQ, or I/O address is already in use by another device, don't try to assign it again. Look in the system menu to see which resources are already in use.
4. Save the settings and exit. Reboot the system. Try the card. It should work. If not, back up your current files and install their software.



PCMCIA card

Windows PCMCIA software

You need this software to insert, remove, or change PCMCIA devices while in Windows for Workgroups. The software allows you to plug and unplug the device while Windows is in operation. **Do not change PCMCIA cards while in Windows if the Windows PCMCIA software is not installed.**

We installed this software at the factory. However, if you reinstall Windows, you also need to reinstall the Windows PCMCIA software.

Note: Put the PCMCIA card into either socket. The system detects the card automatically in either location.

1. Remove any PCMCIA device that may be in the PCMCIA socket. Put the Gateway 2000 Liberty system diskette in the floppy drive.
2. Run Windows and open the Program Manager. Insert the fourth system diskette, labeled Card View/Card Power into the floppy drive.
3. Select **Run** from the File menu.
4. Type

```
a:\setup
```

 and click on **OK**. Press **Enter** at each dialog box to choose the defaults.
5. If you run EMM386, add the following address range to the EMMExclude= line in the [386enh] section of your SYSTEM.INI file. Create the line if it doesn't exist.

```
emmexclude=d000-dfff
```

6. When the installation is finished, exit and restart Windows before you use a PCMCIA device.

If you ever need to reinstall Card View, insert its diskette into the floppy drive and use File, Run to run **A:\setup**. Detailed instructions on reinstallation are in the Software Reinstallation Guide.

Card View



Card View

Card View is a Windows program that tells you what PCMCIA cards you have installed, if any. Keep its icon in the Startup group if you ever use a PCMCIA card. If you don't use the PCMCIA features, or don't need to be shown what you have installed, you can drag the icon into another group.



CardView

When Card View is running, you have an icon in the lower left corner of the screen that shows what is in each PCMCIA slot.

Double-click on this icon to enlarge it to a window and see more details about the PCMCIA card, as illustrated at the top of the next column.

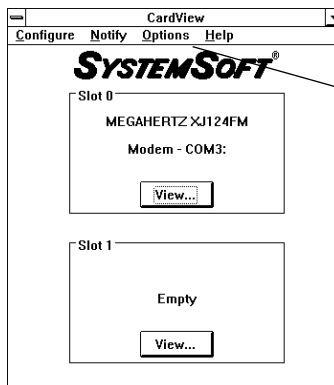

If the system starts up with CardView full size as shown, open the **Options** menu and choose **Run Minimized**.

Click on **View** and you get even more details. The program has an extensive and useful help function.

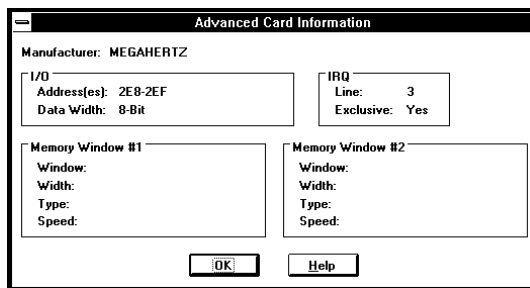

If you ever need to reinstall Card View, insert the Card View diskette into the floppy drive and use File, Run to run **A:\setup**. Detailed instructions on reinstallation are in the Software Reinstallation Guide.

Card Power

Card Power appears automatically whenever you start Windows. It manages the power requirements of PCMCIA cards when the system is in Suspend mode.

Some PCMCIA cards require constant power to retain their settings. Hence, the system does not shut down power to the PCMCIA socket when a card is in the socket. Card Power allows the system to disconnect power to the PCMCIA slot without causing problems. An added benefit is that it restores a modem's settings when you resume from Suspend mode.

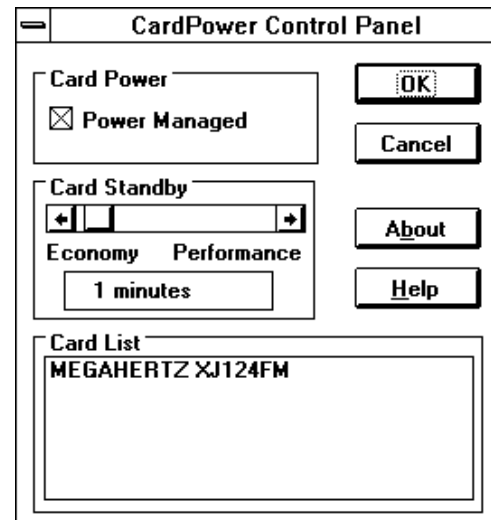

When you start Windows, Card Power appears full size. If the settings are what you want, press **Enter** to minimize it.



Card Power

If you don't use PCMCIA cards, you can drag Card Power's icon out of the Startup folder.

If you ever need to reinstall Card Power, run the Setup program on System disk 4 that came with your Gateway 2000 Liberty. Detailed instructions on reinstallation are in the Software Reinstallation Guide.

Adding memory

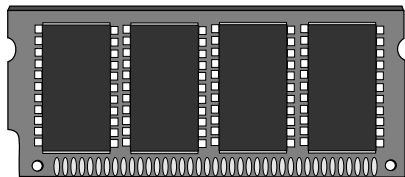

Memory module

You can easily upgrade the memory in your Gateway 2000 Liberty. There are lots of good reasons to add more memory: some programs simply won't work at all without more than 4MB, while others show a noticeable performance improvement with 8MB or more. You will enjoy slightly better battery life under Windows with 8MB or more of RAM, since Windows doesn't have to swap to the power-hogging hard disk as often.

Depending on your system, you can add a single 4MB or 16MB SIMM to the existing memory.

Installing the memory upgrade

IMPORTANT INFORMATION!

You **MUST** turn the power off **EXACTLY** as described below, or **you WILL destroy your RAM upgrade** when you install it.

1. Enter the Setup program (Fn+Esc) and **set the power switch to ON/OFF.**
2. Exit, saving the change (Esc, then F10).
3. Slide the power switch to shut down the system.

4. Close the unit and turn it over.
5. [Disconnect the AC power and remove the battery \(see page 7\).](#)
6. Remove the memory expansion socket cover on the bottom of the unit to expose the socket.
7. Make sure you are grounded to the computer by touching the metal part of the parallel or serial port.
8. Carefully insert the memory module into the socket. It goes in only one way.
9. Replace the memory socket cover.
10. [Reinstall the battery and reconnect the AC power.](#)
11. Turn the computer right side up and open the lid. Push the power switch. The Gateway 2000 Liberty restarts and automatically recognizes the new memory.

If the memory test during start-up shows errors, or if the setup program shows the wrong amount of memory, repeat the installation steps; remove and replace the memory card. If the problem persists, contact Gateway 2000 for repair or replacement.

Opening for memory module
(your's may look different)

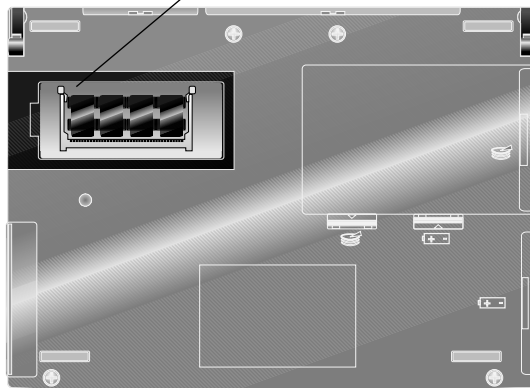

Underside of system; hinge at top.

Troubleshooting

If your Gateway 2000 Liberty is misbehaving, read through this section before you call Gateway 2000 Customer Support. The problem may be something simple that you can quickly solve yourself, and you may save yourself some time on hold.

If nothing here helps you, call us! The Warranty supplied with your Gateway 2000 Liberty describes several ways to contact us, from a traditional voice telephone call to a message on CompuServe or AOL.



The system is dead. Battery light is not lit, no whirring noise from hard disk. Indicator lights below the screen are not lit.

- ❑ **Is the battery charged?** Plug in the AC adapter. The computer does work if the battery is dead.
- ❑ **Is there power at the outlet?** Plug something you know works into the outlet. If it doesn't work, suspect a faulty wall outlet or blown circuit breaker or fuse.
- ❑ **Could something have damaged the power cable,** such as a big yank or getting caught in something?
- ❑ **Is the AC adapter functioning?** Plug in the AC adapter. If the indicator on the AC adapter itself (not the one on the battery) lights up, the adapter is getting AC. If the battery indicator doesn't glow green or orange, try another battery. If it doesn't work either, the AC adapter is defective.

If just one of your batteries doesn't glow green or orange when connected to the AC adapter, that battery is defective.

The AC outlet, AC adapter, and battery check out OK, but the Gateway 2000 Liberty is still dead.

Try pushing the reset button on the bottom of the computer with a toothpick or unbent paper clip. (A ball point pen works, but it may gum up the switch with ink.) After resetting, be sure to wait for a full boot cycle; it can take a long time.

The system is hung when I attempted to reactivate with power switch.

- ❑ If this problem happens very rarely, it might be caused by a static electricity discharge. There's not much you can do about this; the unit is very well protected against static electricity, but any computer will hang or reboot if it gets zapped. This is inconvenient, but as long as you remember to save your work before closing the lid or operating the power switch, you'll never lose anything.

Screen is blank, but the light on the battery is green, and the drive lights blinked.

- ❑ Try adjusting the brightness and contrast controls.
- ❑ Give the system enough time to fully boot, to be sure the screen really is blank. The only thing on the screen might be the C:\> prompt, which is inconspicuous.
- ❑ Finally, call Gateway 2000 Customer Support.

The system boots from floppy disk, but doesn't boot from hard disk.

The hard disk boot track may have been scrambled. It was probably caused by a transient problem such as static electricity or physical shock. Try reinstalling the system files with the SYS command as described in your MS-DOS manual.

If the hard disk still won't boot, but you can read data and other files, back up the files and then reformat the drive as described in the DOS manual. Restore your data and applications.

I changed my AUTOEXEC.BAT or CONFIG.SYS file, and now the computer won't restart.

- ❑ If you have a floppy drive, you can boot with it and the MS-DOS disk shipped with your Gateway 2000 Liberty.
- ❑ Press **F8** briefly when the "Starting MS-DOS..." appears on the screen after a reset. This allows you to step through the items in CONFIG.SYS and AUTOEXEC.BAT and choose whether to run or skip each item.
- ❑ Or you can bypass these files entirely by pressing **F5** briefly when "Starting MS-DOS..." appears on the screen after a reset. Then use the Edit program to correct the file.
- ❑ Another approach is to use the Emergency Boot Drive option. Press **Fn+Esc** to enter the Setup program. Change the Boot Drive option to **EMERGENCY**. Exit saving changes. When the system reboots, your C: drive is a special 2MB partition with several backup files and utilities. Your normal drive C: is drive D:. Now you can copy or edit your system files to recover the drive. Be sure to enter the Setup program when you are done change the boot drive option back to its former setting.

11 Communications

When I resume, the screen lights up and Windows is OK, but the modem doesn't work any more.

This often occurs with communications programs like WinCIM and AOL. After turning the computer back on, pop the modem out and put it back in again. You'll hear two beeps (the "happy beep"). Restart the software. Now the software should work.

If the software still doesn't recognize the modem, exit the program and restart the system by pressing **Fn+Alt+Del**.

When I use Windows Terminal or another communications application, it can't find my modem.

Remove and reinsert the modem, listening for the "happy beep." If you hear this, the modem is probably working OK—check your software and make sure it is set for the right COM port. As shipped from the factory, the modem is configured for COM 3. Somewhere in your program is an option to configure the COM port. Make sure it is set for COM 3.

Sometimes I have a problem transmitting faxes with my Gateway 2000 Liberty and a PCMCIA modem.

You may have better success if you disable the Power Management feature on your computer.

1. Enter the **Control Panel** under Program Manager in Windows.
2. Double-click on the **Power** icon to open the Power Management utility window.
3. Click on the **Enable APM** option once to remove the X and disable the Power Management feature.

4. Complete your fax transmission. You don't need to reboot windows before faxing. The change in the Power Management utility automatically takes effect.
5. After completing your fax, return to the Power Management utility and click once on the **Enable APM** option to enable the Power Management feature.

If you continue to experience problems, contact Gateway 2000 Portables Technical Support.

Sometimes when I try to send a fax, it can't find my modem, even though I just used it a couple of minutes ago with another program.

Do you have another communications program loaded? Communications programs tend to seize complete control of the system's COM port when you load them. When the next communications program (say, your fax application) comes along, the first program won't let go of the COM port. In technical terms, we call this "device contention."

There is no elegant solution to this problem. The easiest thing to do is to close all communications programs before you try to send a fax. Some communications programs are written to coexist peacefully with fax software. You might try one of these.

I can't make my PCMCIA modem work.

Be sure the regions C800-CBFF, D000-DFFF, and EC00-EFFF are excluded in the EMM386 line in CONFIG.SYS. (Look in the file and see if the EMM386 line has $x=C800-CBFF$ etc. in it.) If you purchased a PCMCIA device with your Gateway 2000 Liberty, this has already been done.

Note: Do not use your PCMCIA modem on a digital phone line! Modems convert digital signals into analog signals that are sent on normal, analog telephone lines. If you attempt to use a line that is already digital, the modem will not work and could blow a fuse and become unusable. If you are in doubt about the type of line you have, ask your phone service supplier.

My PCMCIA card stopped working.

Did you make any changes to the PCMCIA software? If so, you may need to reconfigure the PCMCIA software. If you know this isn't the problem, you may have simply changed your system configuration. Each time you change system configuration, such as making a change to your EMM386 settings, you need to run CONFIG ([only applies to Windows for Workgroups users](#)) again. To run CONFIG:

1. Restart the system by pressing **Fn+Alt+Del**.
2. If necessary, exit Windows; type:

```
cd\cardsoft
```

and press **Enter**.
3. At the DOS prompt type:

```
config
```

and press **Enter**.
4. Choose **Edit Configuration...** from the File menu. A list of types of cards appears.



- Select your type of card from the menu. A screen for changing settings appears. The screen for a modem card is shown below.



- Change parameters as necessary to remove conflicts with the rest of the system. You can press **Fn+Esc** at any time to see the settings in the Setup program. You can also view many settings by choosing Resource Allocation from the Utility menu.



My PCMCIA card stops working after the Gateway 2000 Liberty goes into Suspend mode.

This may happen when using communication programs such as WinCIM in Windows. After you press the resume button (and enter the password if you have one) if you don't hear the "happy beep" indicating that the card has been recognized, eject the card then reinsert it. Restart the software. Now it should work.

Network cards are a different matter. Configure your Gateway 2000 Liberty power management so it never goes into Suspend mode. You may have to reboot to access the network. Remember to re-enable Suspend when you remove the card.

If you keep the Card Power icon in your Startup group, most of these problems will go away (doesn't effect network cards).

I Memory

When using Windows, I receive one of the following out of memory errors:

Application Execution Error

Insufficient memory to run this application

There is not enough memory available.

We wish there was a simple solution we could give you. Unfortunately, these error messages could be caused by one of any number of problems, and you may have to try quite a few things before you discover the solution. All we can do is point you in the right direction:

- Close one or more applications. In general, you should keep as few applications running as possible.
- Minimize seldom-used groups and make open windows large enough to eliminate scroll bars.
- Increase the size of your permanent swap file.
- Do not use wallpaper, or use a small bitmap and tile it.

- Try not to open groups that have lots of icons. (Make more groups with fewer icons each.)
- Don't load fonts that you don't need.
- Some applications (usually older ones), don't give system resources back until you restart Windows. If you have an application like this, keep it open instead of closing and reopening it many times.
- Optimize conventional memory, using the MemMaker program. Try changing the order in which programs or drivers load: Put bigger ones first.
- Disable applications that start automatically when you start Windows. (Check WIN.INI and the Startup group).
- Use the Program Manager (PROGMAN.EXE) as your Windows shell. Other shells from third parties may take more memory than Program Manager.

I only have about 540K of conventional memory left. This causes a lot of problems.

No kidding! You may simply be loading too much stuff, and the only thing to do is get rid of some of it. However, if you don't use the PCMCIA slots, run the DOS MemMaker program. MemMaker is magic, and if anything can be done to free up more conventional memory, it will do it. If MemMaker fails to help, try rearranging the order of devices in your CONFIG.SYS file. Put bigger devices first.

If you use the PCMCIA slots, do not run MemMaker. For the technical: MemMaker changes or removes excluded memory areas used by the PCMCIA drivers. If you run MemMaker, protect these exclusions.

If you don't need the memory and PCMCIA at the same time, try using two configurations, one for PCMCIA sessions, one for lots of conventional memory.

II Miscellaneous

The EZ Point mouse moves too fast (or too slowly).

You can adjust pointer acceleration (and a lot of other interesting things) in the Mouse Manager program, which you can get to by clicking on **Control Panel** in the Windows Main program group, and then clicking on Mouse. Notice that you can make the pointer bigger or smaller, make it reverse, and make it snap to the default button in a dialog box (very handy!).

The system date says January 1, 1980.

The internal battery that keeps the clock/calendar going ran completely down. This can happen if you leave the battery pack out of the Gateway 2000 Liberty for a day or more. To correct the problem, reset the date in the Setup program or in the Date/Time control panel. Plug the AC adapter into the computer first and leave it attached for an hour or so.

The system clock loses time when it is in Suspend mode.

Make sure the file PMEXT.SYS is in the CONFIG.SYS file and that the file itself has not been deleted from the hard drive. The line may look something like one of these:

```
DEVICE=c:\UTILS\PMEXT.SYS
```

Why doesn't the DOS manual have a command reference anymore?

Those huge DOS manuals that most of you never read were making a big dent in the tree supply. So we put the same information that was in the paper manual on disk instead. Go to the DOS prompt and type **HELP**. You can take it from there.

I just deleted my CONFIG.SYS and AUTOEXEC.BAT files.

No problem. We stored backups of the files in the C:\BACKUP directory. Just copy them into the C:\ directory, and you're back in business. Of course, keep in mind that the files are set up at the factory—any changes you made since you got the Gateway 2000 Liberty are history. You might still get lucky, though. Look in the C:\ directory for backup copies of the files made when you installed a new option or application. They'll be named something like AUTOEXEC.OLD, AUTOEXEC.001, CONFIG.BAK, CONFIG.002. Rename them to AUTOEXEC.BAT and CONFIG.SYS.

An error message appears on the screen:

General Failure reading drive C:

Try rebooting a couple times. Be sure the unit isn't too cold. If nothing works, call Gateway 2000 Customer Support.

Non-system disk or disk error reading drive A:

You have a non-bootable disk in drive A: (the external floppy disk drive). Remove it and press any key.

Bad command or file name

You may have mistyped a DOS command or there may be a bad command in the AUTOEXEC.BAT file. Retype the command. If you know what you're doing, edit the AUTOEXEC.BAT to correct the error. Or press **F8** during the boot and step through the boot commands. If you don't know anything about the AUTOEXEC.BAT file, find someone who can help you.

For information on other error messages, refer to the DOS or Windows manuals.

All of a sudden, the system won't accept my password.

Check the indicators for Caps Lock, Num Lk, and Pad Lk. If any of them are on, turn them off. (You can do this before entering the password.) Then try retyping the password.

I forgot my password.

Try to prevent this! We made the password feature very secure and there is no easy way to erase a forgotten password. You have to return your Gateway 2000 Liberty to Gateway 2000 for a time-consuming repair. Call Gateway 2000 Customer Support. Or think until you remember it.

I bought this thing because I wanted great performance. I'm not impressed.

Before you give up, remember that most notebooks are set up to provide a reasonable compromise between battery life and performance. Your computer is loaded with power management software that extends the amount of time you can work off of the battery. There's no free lunch though; that extended battery life comes at the expense of performance.

We tried to choose settings that give the best compromise, and we tested these settings on heavy-duty programs like Excel and PageMaker. But if our settings don't work for you, you can customize the degree of power management your Gateway 2000 Liberty uses by changing the power management settings in the system Setup program (described elsewhere in this book). You don't have to *completely* disable power management to improve performance—try moderate changes at first. Also, remember that the system Setup program lets you select separate settings for battery and AC operation. There's no reason not to completely disable all the power management features when running with AC.

I bought the Gateway 2000 Liberty because I wanted great battery life. I'm not impressed.

Fully discharge the battery twice when you first get it. (Give it a full charge before each discharge.)

You can do several additional things to save battery life, although they might cost you a little in terms of performance. You may never notice the performance difference—experiment!

Things that improve battery life:

- ❑ Accessing the hard drive and powering the backlight take the most power. The more you reduce these, the longer your battery lasts between charges.
- ❑ Use the Suspend mode often. It doesn't take long or use much power to reactivate, and Suspend saves battery power.
- ❑ You may have heard about using POWER.EXE for power management—**don't!** The power management features built into the unit work better than POWER.EXE.
- ❑ Go to the Power option in the Windows control panel. Make sure that power management is set to Advanced.
- ❑ In Windows, the fewer applications you have open, the fewer disk accesses the system makes. Don't get in the habit of automatically opening every possible application you might use—just open the ones you need.
- ❑ Consider using Microsoft Works instead of Word and Excel. The files are compatible, and Works requires fewer memory swaps to the hard disk, reducing disk accesses and saving power.
- ❑ DOS and Windows consume the same amount of power. However, because DOS in a window has better *memory* management than regular DOS, you can sometimes reduce disk accesses by running DOS programs in a DOS window within Windows, instead of directly from DOS. (Disk accesses take lots of power, so anything that reduces them lengthens battery life.)
- ❑ Use the Contrast, *not* the Brightness control to adjust the screen. Keep the brightness control set low.

My screen looks a little dark in Windows.

This is often caused by someone changing the Color settings in the Windows Control Panel.

To change color settings in Windows 95, double click on the **Display** icon in the Control Panel. Click on the **Appearance** tab. Select the option labeled Windows Standard.

To change color settings in Windows for Workgroups, double-click on the **Color** icon in the Control Panel. (It looks like three crayons.) Select the option labelled Windows Default from the drop-down list. (It's usually first in the list.)

I can't install new software from the floppy disk drive—the computer keeps hanging.

Power management doesn't mix well with Windows setup programs. When you install a new application from a floppy disk, it's best to have the AC Adapter connected.

I hooked up a scanner to the parallel port and installed its software, but I can't make it work.

The parallel port is probably not set for bidirectional mode, which is required for many scanners. Bring up the Setup program by holding down the **Fn** key and then pressing the **Esc** key. Then go to the Port Assignment section and set the parallel port to Bi-Directional.

The battery indicator glows bright red when I plug in the AC Adapter.

The adapter has detected a fault condition. Usually a plug is loose. Unplug all three plugs and then plug them in again. The indicator should glow orange now.

I don't like the EZ Point!

Be honest now, how much time have you spent using it? OK, now how long did it take you to learn how to ride a bicycle? Seriously, give it a chance! It takes most people several hours to get it, but once they do, they like it.

A

AC adapter
3 6 8 9, 10, 16, 20, 25, 28
AOL 26
arrow keys 12
ATA hard drive 22
AUTOEXEC.BAT 15
autoexec.bat 25

B

back-up copies 17
backlight 29
Battery 7, 19, 28
battery charger 8
battery life 4
Battery light 8
Battery pack 6, 7
BattStat 14
Baud Rate 17
BkSp 18
boot problems 25
Break 11
Brightness 29
brightness 8, 25

C

CapsLock 8, 28
Card Power 15, 23, 27
card services 22
CardView 15, 23
CardID 22
CARDID.INI 22
cardsoft 26
Chargerlight 8
ChipCRT 18
ChipsCPL 14
Cirrus Socket Services 22
COM 1 19
COM 2 19
COM port 17, 22
com port 26
COM ports 19
COM1 16
COM3 26
CONFIG.SYS 15, 28
config.sys 25, 27
Contrast 8, 29
contrast 25
contrast control 10
Control Panel 13, 29
conventional memory 27
CPU 20
CPU performance 20
CRT 18
CSALLOC 26
CSALLOC.EXE 22
Ctrl+Alt+Del 10
cursor 12

D

database 4
desktop 12
device contention 26
Disk activity lights 8
DOS 13, 25
double-clicking 12
Drive cable 9

E

ECP/EPP 19
EMERGENCY 18
Emergency boot 4
Emergency Boot Drive 25
EMM386 23, 26
Esc 18
Ethernet 16
exchanging files 16
external keyboard 3, 10
EZ Point 8, 11, 12, 28

F

F10 18, 24
F5 15, 25
F8 15
fax 26
FDD/HDD 18
File Manager 13
File, Run 13
file transfer 16
flash memory card 22
floppy disk drive 16
floppy drive 19
Fn key 11
Fn+Alt+Del 10, 26
Fn+Esc 11, 24
Fn+F3 11, 14
Fn+F4 11
Fn+F5 11
Fn+F6 11
Fn+F7 11
fonts 27
foot 6

G

groups 12

H

ham radio TNC 16
HandBook486 16
hard disk 4
Hard disk drive 6
hard disk timer 20
Hard drive 7
HDD 18
hot-swapping 3

I

I/O address 22
icons 12
InterLink 16
IR 4, 16, 19
IR connector 6, 16
IR module 9, 16
IR port 3, 16, 17, 19
IRDA 16
IRQ 22
IRQs 19

J

joystick 12

K

keyboard 10, 11
Windows 95 11
keyboard menu 21
keycaps 11

L

large screen TV 4
LCD 11, 18
LCD & CRT 18
LCD display 8
LCD overhead projector
panel 16
lid closed 20
LPT 1 19

M

MemMaker 27
Memory 7
memory 24
memory expansion socket
24
memory test 24
modem
16, 17, 18, 26, 27
monitor 10, 16
Mouse buttons 8
mouse buttons 11, 12
MTAA.EXE 22
MTAB.EXE 22
MTATM.EXE 22
MTDDR.VEXE 22
MTI1.EXE 22
MTI2.PEXE 22
MTSRAM.EXE 22

N

network card 22
Network cards 27
network PCMCIA card 3
notebook 4
nulmodem 16
Num Lk 8, 11, 28
Num Lock 8, 11
numeric keypad 8, 11

O

on-off switch 6, 10

P

Pad Lk 8, 11, 28
padLock 8
page down 12
page up 12
parallel cable 16
parallel port 6, 17
parallel port 9, 19, 29
password 19, 28
change 19
disable 19
Pause 11
PCMCIA 6, 9, 16, 17, 26
PCMCIA cards 23
PCMCIA connector 22
PCMCIA door 8
PCMCIA modem 17
PMEXT.SYS 28
Power 29
power cable 25
Power control panel 14
power management
14, 19, 28
Power switch 6
power switch 10, 18
POWER.EXE 29
printer 16
Program Manager
13, 15, 27
projection panel 4
PS/2 connector 6
PS/2 mouse 3

R

- RAM 4
- reinstall Card View 23
- reinstallTranXit 17
- Reset 10
- Reset switch 7, 10
- ROM BIOS 18

S

- scanner 17
- serial port 16
- serial cable 16
- serial mouse 3
- Serial port 6
- serial port 19
- setup menu 17, 18, 29
 - entering 17, 18, 29
 - leaving 18
 - selecting items 18
- Setup program 18
- spacebar 18
- Speaker 11
- Specs 5
- spreadsheet 4
- SRAM 22
- SRAM card 22
- SSMSFLSH.SYS 22
- Standby 10, 20
- standby timer 20
- Startup group 27
- static electricity 24, 25
- subnotebook 4
- Suspend 10
- suspend 18, 20
- suspend timer 20
- suspend-resumeswitch 18

T

- TechnicalSupport 25
- tic electricity 25
- tool bar 13
- TranXit 16
- troubleshooting 25
- typematic functions 21

V

- VGA 8
- video 18
- video control panel 14
- Video port 6
- video timer 20

W

- WIN.INI 27
- WinCIM 27
- Windows 4, 12, 22
- Windows 95
 - 4, 5, 12, 13, 15, 22
 - keys 11
- word processing 4

