HP F1381A Port Replicator for the HP OmniBook 3000

— User's Guide

Notice

This manual and any examples contained herein are provided “as is” and are subject to change without notice. Hewlett-Packard Company makes no warranty of any kind with regard to this manual, including, but not limited to, the implied warranties of merchantability and fitness for a particular purpose. Hewlett-Packard Co. shall not be liable for any errors or for incidental or consequential damages in connection with the furnishing, performance, or use of this manual or the examples herein.

Consumer transactions in Australia and the United Kingdom: The above disclaimers and limitations shall not apply to Consumer transactions in Australia and the United Kingdom and shall not affect the statutory rights of Consumers.

© Copyright Hewlett-Packard Company 1997. All rights reserved. Reproduction, adaptation, or translation of this manual is prohibited without prior written permission of Hewlett-Packard Company, except as allowed under the copyright laws.

The programs that control this product are copyrighted and all rights are reserved. Reproduction, adaptation, or translation of those programs without prior written permission of Hewlett-Packard Co. is also prohibited.

Portions of the programs that control this product may also be copyrighted by Microsoft Corporation, SystemSoft Corp., Crystal Semiconductor Corporation, Phoenix, and Neo Magic. See the individual programs for additional copyright notices.

Microsoft, MS, MS-DOS, and Windows are registered trademarks of Microsoft Corporation.

Pentium and the Intel Inside logo are U.S. registered trademarks and MMX is a U.S. trademark of Intel Corporation.

For warranty information, see the *Support and Service* booklet.

Hewlett-Packard Company
Mobile Computing Division
19310 Pruneridge Ave.
Cupertino, CA 95014

HP Software Product License Agreement

Your HP OmniBook PC contains factory-installed software programs. Please read the Software License Agreement before proceeding.

Carefully read this License Agreement before proceeding to operate this equipment. Rights in the software are offered only on the condition that the customer agrees to all terms and conditions of the License Agreement. Proceeding to operate the equipment indicates your acceptance of these terms and conditions. If you do not agree with the terms of the License Agreement, you must now either remove the software from your hard disk drive and destroy the master disks, or return the complete computer and software for a full refund.

Proceeding with configuration signifies your acceptance of the License Terms.

Unless otherwise stated below, this HP Software Product License Agreement shall govern the use of all software that is provided to you, the customer, as part of the HP computer product. It shall supersede any non-HP software license terms that may be found online, or in any documentation or other materials contained in the computer product packaging.

Note: Operating System Software by Microsoft is licensed to you under the Microsoft End User License Agreement (EULA) contained in the Microsoft documentation.

The following License Terms govern the use of the software:

Use. Customer may use the software on any one computer. Customer may not network the software or otherwise use it on more than one computer. Customer may not reverse assemble or decompile the software unless authorized by law.

Copies and Adaptations. Customer may make copies or adaptations of the software (a) for archival purposes or (b) when copying or adaptation is an essential step in the use of the software with a computer so long as the copies and adaptations are used in no other manner.

Ownership. Customer agrees that he/she does not have any title or ownership of the software, other than ownership of the physical media. Customer acknowledges and agrees that the software is copyrighted and protected under the copyright laws. Customer acknowledges and agrees that the software may have been developed by a third party software supplier named in the copyright notices included with the software, who shall be authorized to hold the Customer responsible for any copyright infringement or violation of this Agreement.

Product Recovery CD-ROM. If your computer was shipped with a product recovery CD-ROM: (i) The product recovery CD-ROM and/or support utility software may only be used for restoring the hard disk drive of the HP computer with which

the product recovery CD-ROM was originally provided. (ii) The use of any operating system software by Microsoft contained in any such product recovery CD-ROM shall be governed by the Microsoft End User License Agreement (EULA).

Transfer of Rights in Software. Customer may transfer rights in the software to a third party only as part of the transfer of all rights and only if Customer obtains the prior agreement of the third party to be bound by the terms of this License Agreement. Upon such a transfer, Customer agrees that his/her rights in the software are terminated and that he/she will either destroy his/her copies and adaptations or deliver them to the third party.

Sublicensing and Distribution. Customer may not lease, sublicense the software or distribute copies or adaptations of the software to the public in physical media or by telecommunication without the prior written consent of Hewlett-Packard.

Termination. Hewlett-Packard may terminate this software license for failure to comply with any of these terms provided Hewlett-Packard has requested Customer to cure the failure and Customer has failed to do so within thirty (30) days of such notice.

Updates And Upgrades. Customer agrees that the software does not include updates and upgrades which may be available from Hewlett-Packard under a separate support agreement.

Export Clause. Customer agrees not to export or re-export the software or any copy or adaptation in violation of the U.S. Export Administration regulations or other applicable regulation.

U.S. Government Restricted Rights. Use, duplication, or disclosure by the U.S. Government is subject to restrictions as set forth in subparagraph (c)(1)(ii) of the Rights in Technical Data and Computer Software clause in DFARS 252.227-7013. Hewlett-Packard Company, 3000 Hanover Street, Palo Alto, CA 94304 U.S.A. Rights for non-DOD U.S. Government Departments and Agencies are as set forth in FAR 52.227-19(c)(1,2).

Edition History

Edition 1 September 1997



This manual is printed on recycled paper.

Contents

1. Using the Port Replicator	1-7
Understanding the Basics	1-9
To dock the OmniBook	1-10
To undock the OmniBook	1-12
To reset the OmniBook	1-12
To attach a security cable	1-13
Making Connections	1-14
To connect an external keyboard	1-15
To enable an external Fn key	1-15
To connect a PS/2 mouse	1-16
To switch back to the internal TouchPad	1-16
To connect a serial mouse	1-17
To connect a serial device	1-17
To connect a Universal Serial Bus (USB) device	1-18
To connect an external display	1-18
To use the monitor stand with an external display	1-19
To enable the built-in and external displays	1-19
To connect a parallel device	1-20
To connect a MIDI/Joystick device	1-20
To connect your audio equipment	1-21
2. Troubleshooting	1-23
Solving Problems	1-25
3. Specifications and Regulatory Information	1-27
Specifications	1-29
Regulatory Information	1-30
U.S.A.	1-30
Canada	1-31
Japan	1-31
Declaration of Conformity	1-32



Using the Port Replicator

Using the Port Replicator

Congratulations! With the OmniBook port replicator, you can significantly increase the convenience of your OmniBook for desktop use. By making one connection—plugging your OmniBook into the port replicator—you can get easy access to these types of devices:

- ◆ Printer or other parallel device.
- ◆ Modem or other standard serial device.
- ◆ Universal Serial Bus (USB) devices.
- ◆ External keyboard and external mouse.
- ◆ External monitor.
- ◆ Audio connections.
- ◆ AC power.
- ◆ MIDI/Joystick.

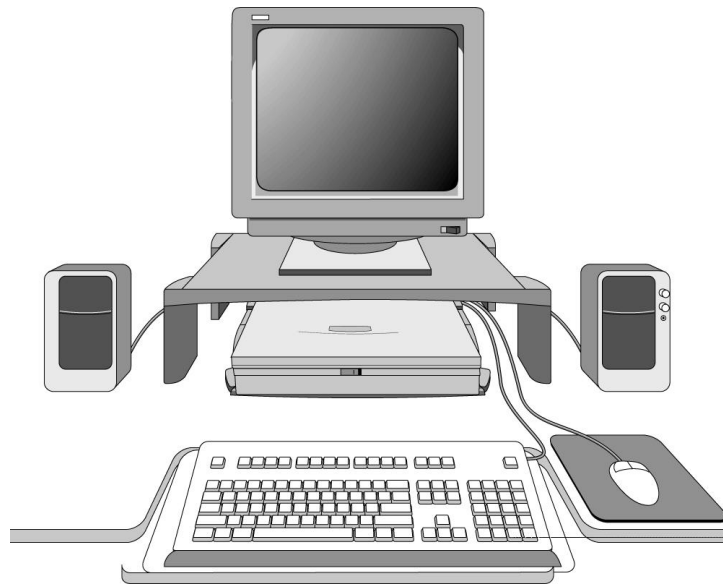

Understanding the Basics

Docking the OmniBook to the port replicator is just like simultaneously adding several devices to the OmniBook. Docking does not cause Windows 95 to create a new hardware profile. Similarly, undocking does not create an undocked profile.

This section shows you how to get your port replicator and OmniBook up and running quickly, including how to

- ◆ Dock the OmniBook.
- ◆ Undock the OmniBook.
- ◆ Reset the OmniBook while docked.
- ◆ Attach a security cable.

To dock the OmniBook

CAUTION

Use only an HP F1377A ac adapter (the type shipped with the OmniBook) —do not use an ac adapter from another product. Using an improper adapter could damage the OmniBook and will make your warranty invalid.

1. Plug the power cord into the ac adapter, then into an ac outlet. Plug the ac adapter into the port replicator.

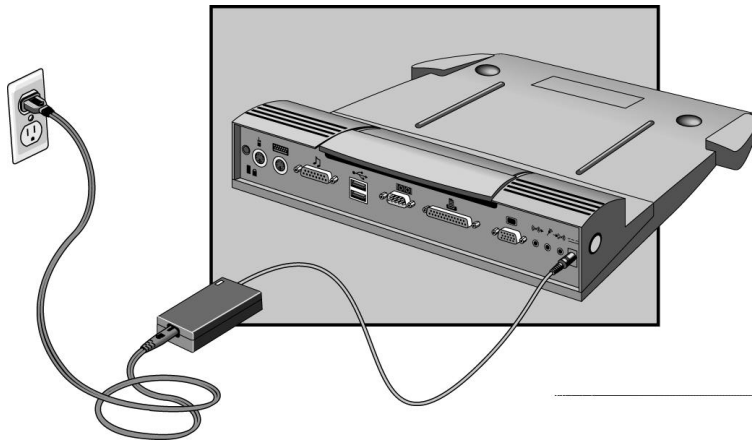

2. Slide the OmniBook's rear port door to the left.

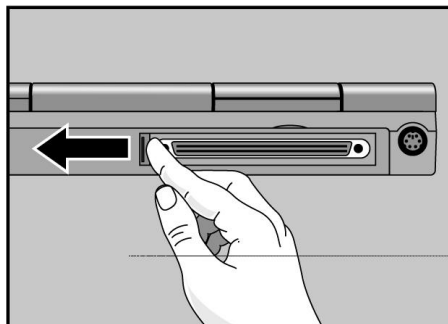

3. Place the OmniBook on the port replicator platform, with the back of the computer facing the port replicator's docking connector.

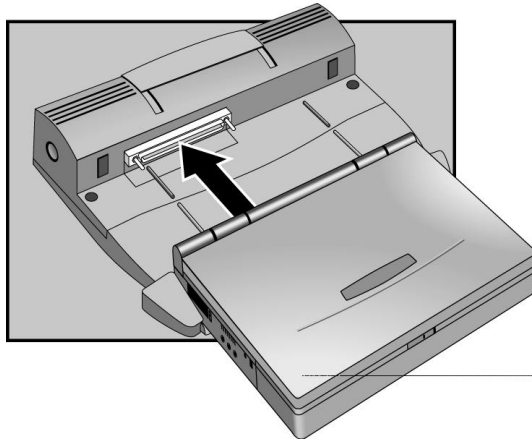

4. Position your fingers on the platform grips as shown below. Use your thumbs to push the computer firmly toward the port replicator until the OmniBook slides into place.

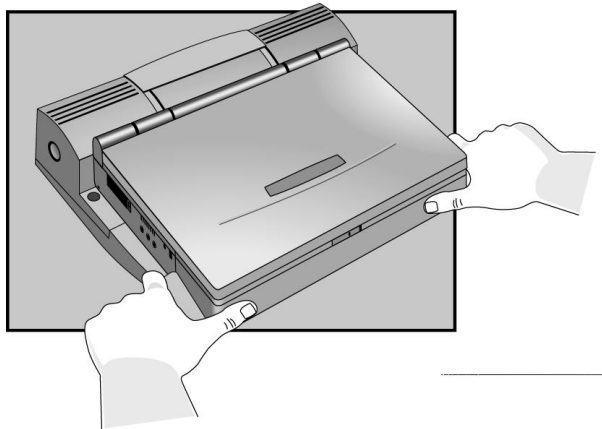

To undock the OmniBook

1. Raise the release lever at the top of the port replicator.
2. After removing the OmniBook, push the release lever back into place.

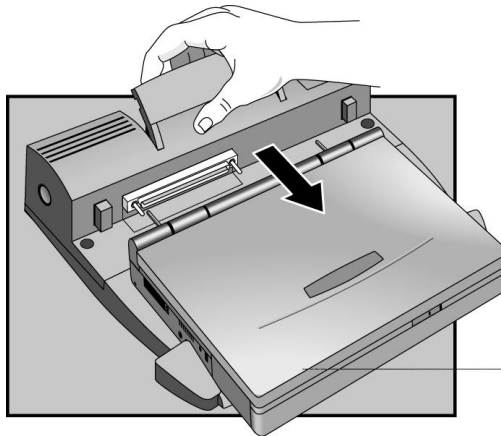

To reset the OmniBook

You can reset the OmniBook without undocking.

- Press the reset button on the port replicator.
The OmniBook restarts automatically after resetting.

Reset button

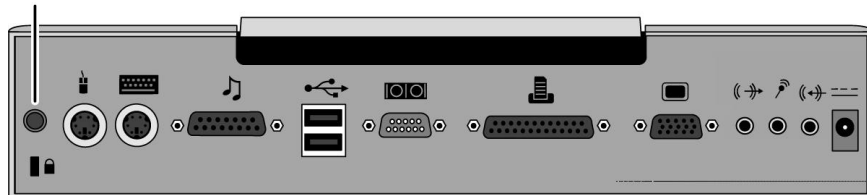

To attach a security cable

Your port replicator has a built-in security port that allows you to secure the port replicator with a cable. *Be sure to use a second Kensington lock to secure the OmniBook.* Kensington MicroSaver lock systems work with these ports and are available at many computer stores.

1. Wrap the cable around a stationary object, such as a table leg.
2. Loop the cable to create a slip knot around the stationary object.
3. Insert the lock into the port replicator's security port and release the key. Store the key in a safe place away from the OmniBook.

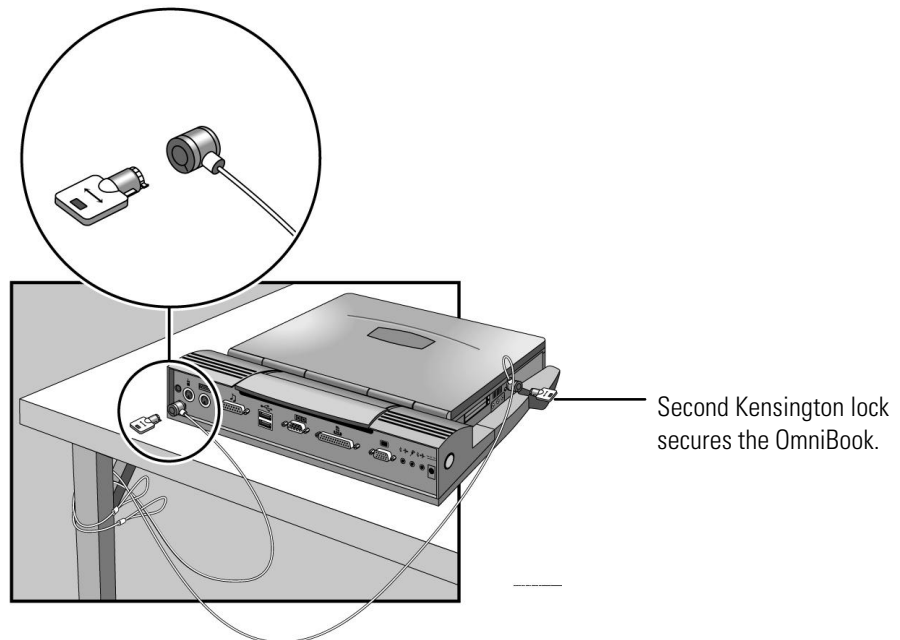

Making Connections

When making connections, notice that the orientation of the ports on the port replicator are the reverse of the OmniBook. Turn the connector cables over when switching from the OmniBook to the port replicator. This section describes how to connect devices to the port replicator, including the following:

- ◆ External keyboard.
- ◆ External PS/2 or serial mouse.
- ◆ Standard serial device (9-pin).
- ◆ Two Universal Serial Bus (USB) devices.
- ◆ External display.
- ◆ Printer or other parallel device (25-pin).
- ◆ External microphone audio source.
- ◆ Headphones or speakers.
- ◆ MIDI or game device.
- ◆ Kensington security lock.

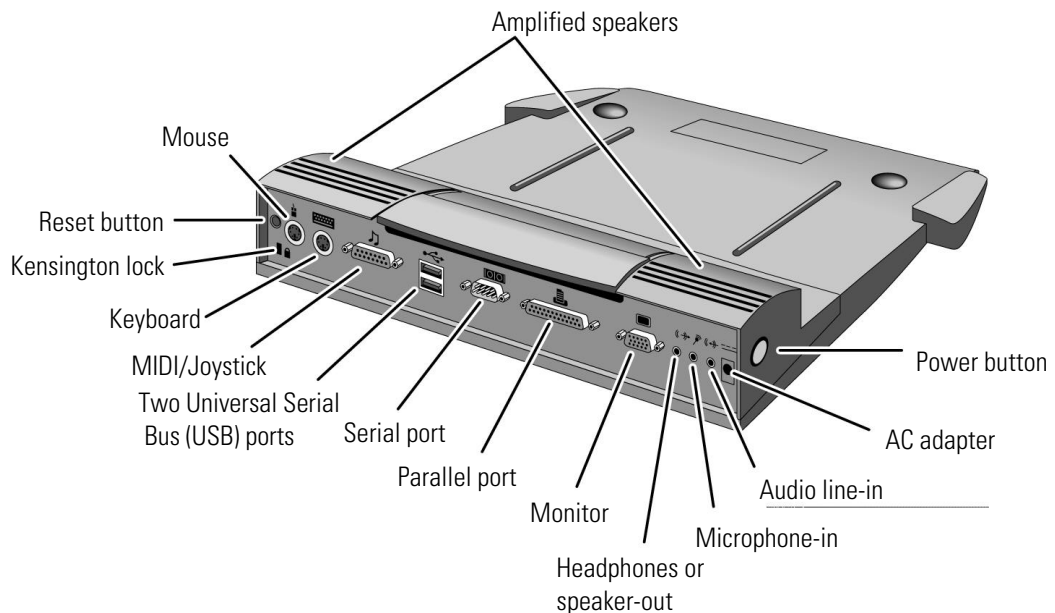

To connect a PS/2 mouse

The OmniBook has a PS/2 mouse driver installed. When you dock, the OmniBook automatically detects and sets up the mouse.

1. Attach the mouse cable to the mouse port.
2. Dock the OmniBook in the port replicator.

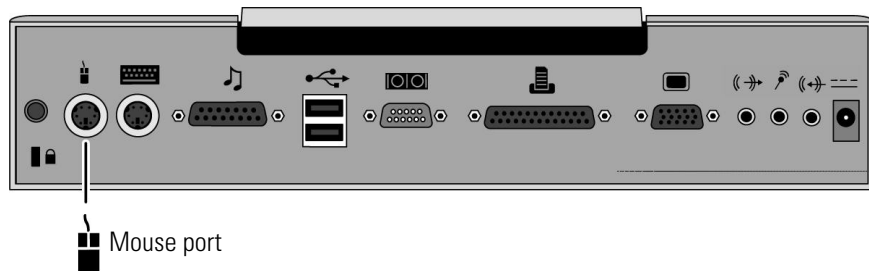

To switch back to the internal TouchPad

Use this procedure to switch back to the built-in TouchPad from an external PS/2 mouse while docked.

1. Press the power button to suspend the OmniBook
2. Disconnect the mouse cable from the port replicator.
3. Press the power button to resume.

-or-

Undock, disconnect mouse, then dock again.

To connect a serial mouse

1. Attach the serial mouse cable to the serial port.

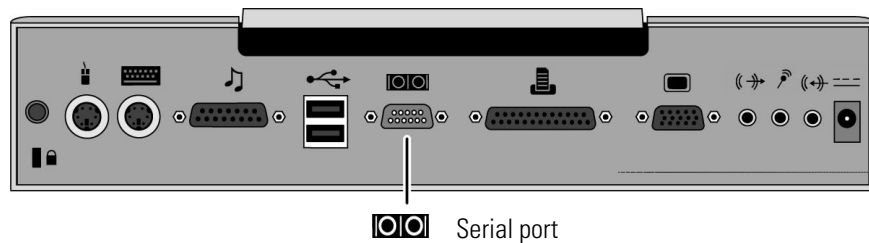

To switch back to the TouchPad, see page 1-16.

2. Dock the OmniBook in the port replicator.
3. Using the TouchPad, click Start, Settings, Control Panel, Mouse, General.
4. Click Change, then select Standard Mouse Types.
5. Select your mouse type from the list, or select Standard Serial Mouse.
6. Click OK, Close, then click Yes when prompted to restart.

To connect a serial device

Use standard serial cables and adapters available at computer dealers and electronic supply stores to connect serial devices.

1. Attach the serial cable to the serial port.
2. Dock the OmniBook in the port replicator.
3. If necessary, install your serial device driver.
See your Windows or device manual for instructions.

The serial port is COM1.

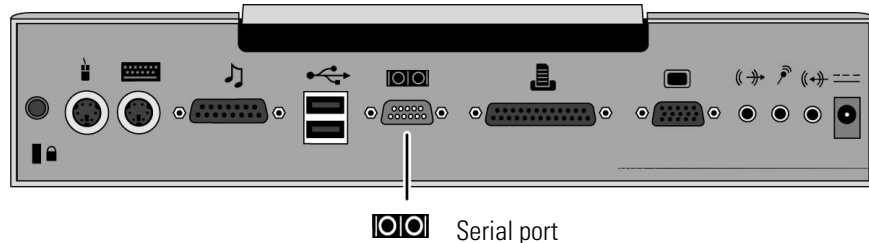

To connect a Universal Serial Bus (USB) device

Universal Serial Bus (USB) provides a bi-directional serial interface for adding peripheral devices such as game controllers, serial and parallel ports, and scanners on a single bus. The OmniBook's port replicator provides two USB ports.

1. Attach the USB cable to either the upper or lower USB port.
2. Dock the OmniBook in the port replicator.

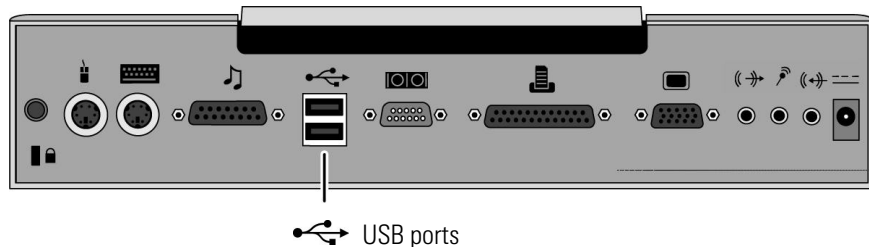

To connect an external display

Use this procedure to connect a standard VGA, SVGA, or XGA external display to your OmniBook.

1. Attach the display cable to the display port.
2. Dock the OmniBook in the port replicator. The built-in display turns off. If you want to run the built-in display and an external display simultaneously, see the following topic for instructions.

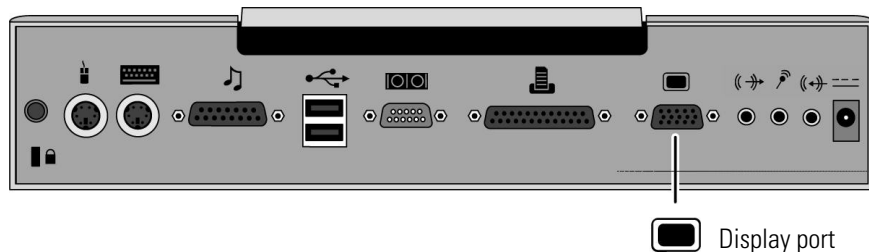

To use the monitor stand with an external display

The optional monitor stand (HP F1369A), can support a weight of 69 kg (151.8 lb.). When setting up the monitor stand, be sure that the wide edge faces forward, as shown below.

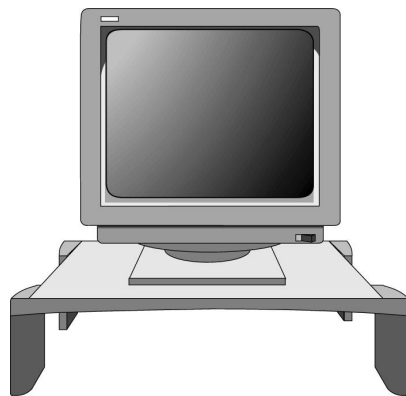

To enable the built-in and external displays

- Press Fn+F5 to cycle through the external and built-in display options (Internal, External, Both).

–or–

1. Close all applications, then shut down Windows and reboot the OmniBook. If necessary, you can press CTRL+ALT+DEL to reboot.
2. When you see the following message, press F2 to enter Setup.
Press <F2> to enter Setup
3. From the Main menu, use the down arrow to highlight Video Display Device.
4. Press Enter to view choices.
5. Select Both.
6. Press F10 to save settings and exit Setup.

To connect a parallel device

Use standard parallel cables and adapters available at computer dealers and electronic supply stores to connect parallel devices.

1. Attach the parallel cable to the parallel port.
2. Dock the OmniBook PC in the port replicator.
3. If necessary, install your parallel device driver.
See your Windows or device manual for instructions.

The port replicator's 25-pin parallel port is a standard enhanced (EPP/ECP) parallel port.

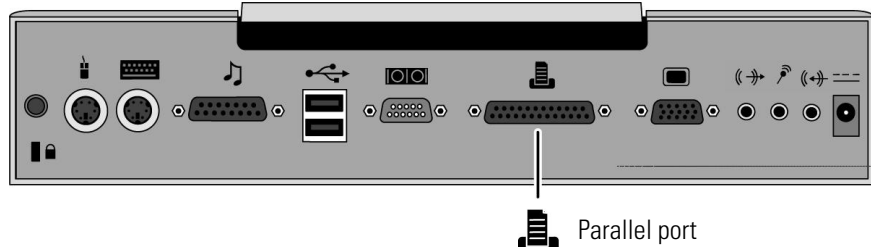

To connect a MIDI/Joystick device

1. Attach the cable to the MIDI/Joystick port.
2. Dock the OmniBook in the port replicator.

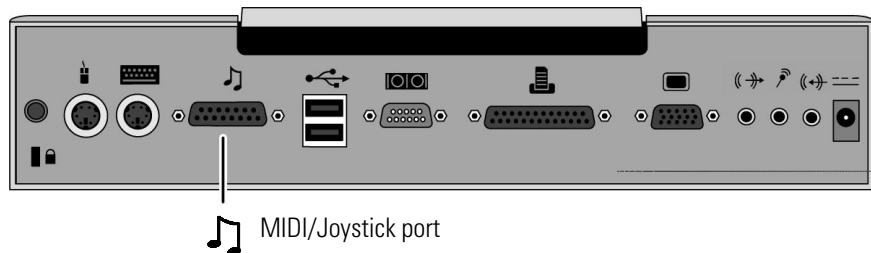

To connect your audio equipment

The port replicator provides the following audio ports:

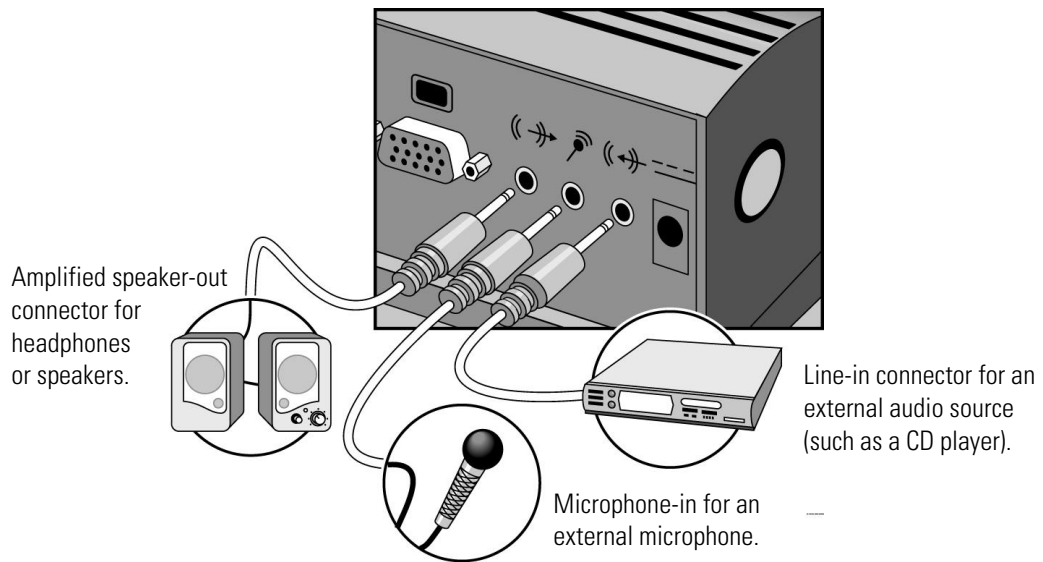

1. Attach the audio cable to the corresponding audio port.
2. Dock the OmniBook in the port replicator.

You can press Fn+F7 to mute the sound. Pressing Fn+F7 again enables the sound.

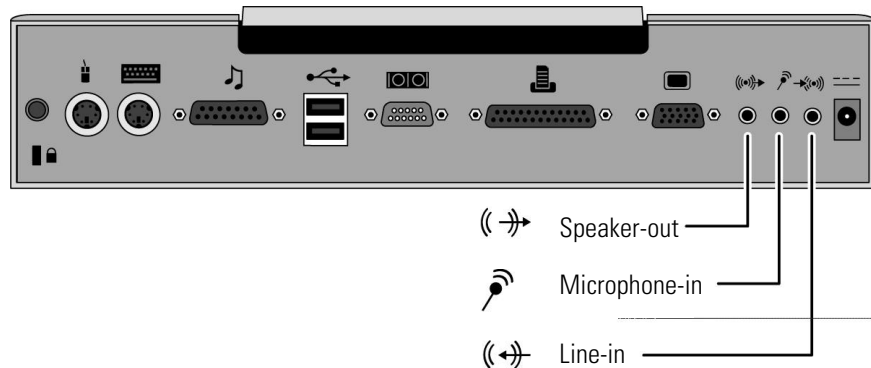



———— Troubleshooting

Troubleshooting

There are many ways to get information and technical support for your OmniBook and port replicator. If you have a question about your port replicator that this manual does not answer, you can try any of the following sources:

The online OmniBook *User's Handbook*

The online manual provides basic information about how to operate and maintain your OmniBook. You can view the manual online or print it.

The printed OmniBook *Reference Guide*

The printed manual provides complete instructions about how to set up the OmniBook, use accessories, install memory or hard disks, connect devices, change the configuration (BIOS Setup Utility), recover OmniBook files, use system resources (including memory maps, interrupt settings, I/O addresses).

The World Wide Web

The HP Web site provides information about HP mobile-computing products. You can download new software and drivers, get detailed setup instructions, or view a list of frequently asked questions and answers. The HP Web site address is <http://www.hp.com/go/omnibook> .

Technical Support

If you'd like to talk to a trained HP representative, you can call Technical Support. If the product is under warranty, the technical assistance is normally free. Your only charge will be the telephone call and you will speak directly to a support specialist. The Technical Support telephone number for your area is listed in the *Support and Service* booklet that you received with your OmniBook.

HP First (automated fax service)

You can also use the HP automated fax service. Through HP First, you can access thousands of documents that provide help or information by fax.

The HP First telephone number is:

(800) 333-1917 (inside U.S. and Canada).

(208) 344-4809 (outside U.S. and Canada).

Solving Problems

If you have a problem using the port replicator, find the symptom that matches your situation. Try the suggestions one at a time.

If you need to replace a lost or damaged power cord

- For the replacement part number for the ac adapter power cord, contact the number in the Support and Service booklet.

If a connection doesn't work

- Try connecting the device to the corresponding port on the OmniBook. This can tell you if the problem is with the port replicator.
- Make sure the OmniBook is fully inserted in the port replicator. The connection should be snug.
- Make sure the ends of the device cable are connected properly.
- Make sure the device and the port replicator are connected and both have power connected and turned on.
- Reboot the OmniBook.

If an external PS/2 mouse or keyboard doesn't work

- Make sure the mouse or keyboard is plugged into the correct port. The mouse and keyboard ports look the same. See page 1-15.
- Check that the PS/2 mouse is enabled in the BIOS Setup Utility.

If you cannot hear audio devices or files

- Fn+F7 mutes the audio system. Pressing Fn+F7 again enables sound.
- Try increasing the volume. Fn + UP ARROW increases the volume.

If an external serial mouse doesn't work

- Check that the correct serial port is enabled in the BIOS Setup Utility.

**Specifications and Regulatory
Information**

Specifications and Regulatory Information

Your OmniBook port replicator is designed to provide trouble-free operation. The following suggestions can help you while working with your OmniBook:

- ◆ If you have problems, see the problem-solving suggestions and references listed in chapter 2.
- ◆ If you think your port replicator might need repair service, see the warranty and service information in the *Support and Service* booklet.

To contact Hewlett-Packard

If you have questions that the OmniBook manuals don't answer (even after looking in the contents and index), you can contact Hewlett-Packard at the address or phone number listed in the *Support and Service* booklet or in OmniBook Support in the online OmniBook Library. Please have your OmniBook with you.

Specifications

Ports	240-pin docking connector. Parallel DB25 (EPP/ECP). Serial DB9 (115,200-bps). VGA port, D-sub 15-pin female connector. 6-pin external keyboard connector. 6-pin external PS/2 mouse connector. Three audio jacks for Speaker-out, Line-in, and MIC-in. 2-pin ac jack for ac adapter. MIDI port: D-sub, 15-pin female for MIDI in/out. 2 Universal Serial Bus (USB) ports.
Power	Includes F1377A ac adapter. 100 to 240 Vac (50 to 60 Hz) input; 19 Vdc, 2.4A output.
Security	Kensington lock slot secures port replicator.
Size	
Height	81.5 mm (3.21 in.).
Depth	320.0 mm (12.60 in.).
Width	356.9 mm (14.05 in.).
Weight	1.67 kg (3.68 lb.).
Environmental	
Operating temperature	5 to 35 °C (41 to 95 °F).
Storage temperature	-20 to 50 °C (-4 to 122 °F).
Relative humidity	10% to 90% (noncondensing).

Regulatory Information

This section presents information that shows how the port replicator complies with regulations in certain regions. Any modifications to the port replicator not expressly approved by Hewlett-Packard could void the authority to operate the port replicator in these regions.

This port replicator is for use only with the I.T.E. (Information Technology Equipment) notebook computer, model HP OmniBook 3000.

U.S.A.

The port replicator generates and uses radio frequency energy and may interfere with radio and television reception. The port replicator complies with the limits for a Class B computing device as specified in Part 15 of FCC Rules, which provide reasonable protection against such interference in a residential installation. The FCC label for this product is visible on the bottom of the unit. In the unlikely event that there is interference to radio or television reception (which can be determined by undocking the OmniBook and unplugging the ac adapter), try the following:

- Reorienting or relocating the receiving antenna.
- Relocating the port replicator with respect to the receiver.
- Connecting the ac adapter to another power outlet.

To maintain compliance with FCC Rules and Regulations, use properly shielded cables when connecting peripheral devices to this device. Use cables supplied with the OmniBook when appropriate.

For more information, consult your dealer, an experienced radio/television technician, or the following booklet, prepared by the Federal Communications Commission: *How to Identify and Resolve Radio-TV Interference Problems*. This booklet is available from the U.S. Government Printing Office, Washington, DC 20402, Stock Number 004-000-00345-4. At the first printing of this manual, the telephone number was (202) 783-3238.

Canada

This digital apparatus does not exceed the Class B limits for radio noise emissions from digital apparatus as set out in the radio interference regulations of the Canadian Department of Communications.

Le présent appareil numérique n'émet pas de bruits radioélectriques dépassant les limites applicables aux appareils numériques de Classe B prescrites dans le règlement sur le brouillage radioélectrique édicté par le Ministère des Communications du Canada.

Japan

この装置は、情報処理装置等電波障害自主規制協議会（VCCI）の基準に基づく第二種情報技術装置です。この装置は、家庭環境で使用することを目的としていますが、この装置がラジオやテレビジョン受信機に近接して使用されると、受信障害を引き起こすことがあります。

取扱説明書に従って正しい取り扱いをして下さい。

Declaration of Conformity

Products sold by Hewlett-Packard and its authorized dealers meet the specifications listed below, according to ISO/IEC Guide 22 and EN 45014.

Manufacturer:	Hewlett-Packard Company
Address:	Hewlett-Packard Co. Mobile Computing Division 1000 NE Circle Blvd. Corvallis, OR 97330 declares that the following product
Product name:	HP F1381A port replicator
Options:	All conforms to the following product specifications
Safety:	IEC 950:1991+A1,A2 / EN 60950 (1992)+A1,A2
EMC:	CISPR 22:1993 / EN 55022 (1994): Class B [1] EN 50082-1:1992 IEC 1000-4-2:1995 / prEN 55024-2 (1992): 4kV CD, 8kV AD IEC 1000-4-3:1995 / prEN 55024-3 (1991): 3V/m IEC 1000-4-4:1995 / prEN 55024-4 (1992): 0.5kV signal lines, 1.0kV power lines ANSI C63.4:1992
Supplementary Information:	The product herewith complies with the requirements of the EMC Directive 89/336/EEC, Part 15 of the FCC Rules (97-6430-006-I), and carries the CE mark accordingly. [1] The product was tested in a typical configuration with Hewlett-Packard personal computer peripherals.

Quality Department
Hewlett-Packard Company
Mobile Computing Division

Index

A
ac power, 1-10
audio
 connections, 1-21
 MIDI devices, 1-20
 mute key, 1-21
 troubleshooting, 1-25

B
BIOS Setup, 1-15

C
cable
 security, 1-13
connecting, 1-17
 ac power, 1-10
 external display, 1-18
 keyboard, 1-15
 MIDI/Joystick, 1-20
 OmniBook, 1-10
 parallel device, 1-20
 printer, 1-20
 security cable, 1-13
 serial device, 1-17
 serial mouse, 1-17
 USB device, 1-18
contacting HP, 1-28

D
Declaration of
 Conformity, 1-32

device
 audio, 1-21
 display, 1-18
 keyboard, 1-15
 MIDI/Joystick, 1-20
 parallel, 1-20
 serial, 1-17
 USB, 1-18
dimensions, 1-29
display
 external, 1-18
 troubleshooting, 1-25
docking, 1-10
documentation, 1-24

E
enabling
 display device, 1-19
 external Fn key, 1-15
 serial mouse, 1-17

F
fax service, 1-24
Fn key
 + F5, 1-19
 + F7, 1-25
 + up arrow, 1-25
Fn key (external), 1-15

H
help, 1-24
HP First, 1-24

J
joystick, 1-20

K
Kensington lock, 1-13
keyboard
 connecting, 1-15
 external Fn key, 1-15

L
license agreement, 1-3

M
MicroSaver lock, 1-13
MIDI, 1-20
modem, 1-17
monitor, *See* display
monitor stand, 1-19

O
OmniBook
 docking, 1-10
 documentation, 1-24
 regulatory, 1-30
 repair, 1-28
 resetting, 1-12
 specifications, 1-29
 support, 1-28
operating temperature,
 1-29

P

parallel device
 connecting, 1-20
 troubleshooting, 1-25

ports
 ac, 1-10
 ac adapter, 1-10
 display, 1-18
 keyboard, 1-15
 MIDI/Joystick, 1-20
 printer, 1-20
 serial device, 1-17

power, 1-29

protection
 security cable, 1-13

PS/2 mouse
 switching back to
 TouchPad, 1-16
 troubleshooting, 1-25

R

regulatory, 1-30

repair, 1-28
reset button, 1-12

S

security
 cable, 1-13

serial
 device, 1-17, 1-25
 USB device, 1-18

service (repair), 1-28

software license, 1-3

specifications, 1-29

support, 1-28

SVGA, 1-18

T

technical specifications,
 1-29

technical support, 1-24

temperature, 1-29

TouchPad, 1-16

troubleshooting, 1-25

U

Universal Serial Bus,
 1-18

USB device, 1-18

User's Guide, 1-24

V

VGA, 1-18

W

weight, 1-29

WWW, 1-24

X

XGA, 1-18