

**MICRONICS**  
C O M P U T E R S I N C .

**LX30WB VL-Bus  
System Board Manual**

Document Number: 06-00220-03, Rev. 2A

July 1995

221 Warren Ave., Fremont, CA 94539-7085

# Copyright Notices

## **Micronics Computers, Inc.**

The information contained in the LX30WB system board manual has been carefully checked and is believed to be accurate. Micronics assumes no responsibility for any inaccuracies that may be contained in this document. Micronics makes no commitments to update or to keep the information in this manual at a current level when changes are made to the product.

Micronics reserves the right to make improvements to this document and/or product at any time and without notice.

All Rights Reserved. No part of this document may be photocopied, reproduced, translated, or reduced to any medium or machine form without prior, written consent from Micronics.

COPYRIGHT (C) 1994, 1995 Micronics Computers, Inc.

## **Portions of the Manual**

Portions of this manual were copied (with permission) from Phoenix Technologies, Ltd. Copyright 1994. All rights reserved.

## **Trademarks**

IBM is a registered trademark of International Business Machines. Microsoft, Microsoft Word, Windows are registered trademarks of Microsoft Corporation. Intel and PCI are registered trademarks of Intel Corporation. UNIX is a registered trademark of AT&T Corporation. Lotus 1-2-3 is a registered trademark of Lotus Development Corporation. All other product names mentioned herein are used for identification purposes only and may be the trademarks of their respective companies.

# ***Micronics Quick Installation***

We know many experienced people prefer to read as little of the documentation as possible. If this sounds like you, here's the short form:

1. Ground yourself to prevent damaging static discharge, then remove the LX30WB from its packaging.
2. Configure and verify the system board's jumper settings. (See Jumper Settings in Chapter 2)
3. Install the CPU and the system memory. (Chapter 3)
4. Install the motherboard into the system case and make all of the necessary case connections.
5. Install any peripherals (Chapter 3). Do not replace the computer cover until you have verified the system is working properly.
6. Turn the computer on and press the <Ctrl>, <Alt>, and <Esc> keys simultaneously after you see the screen below:

Phoenix 80486 ROM BIOS PLUS, Version 0.10 LX30-01  
Copyright (c) 1985-1990 Phoenix Technologies Ltd.  
All Rights Reserved

640K Base Memory

xxxxxK Extended

7. Set the time and date. Adjust the BIOS settings to match what is installed in your system. If installing an IDE drive, select the IDE device you wish to configure. Press <Enter> with AUTO CONFIG selected and the BIOS will automatically configure the drive for you. (See Chapter 4)
8. After you have configured the BIOS settings, press the <Esc> key followed by the <F4> key to save the changes and exit. The system will reboot and be ready for use.

# Contents

**Introduction** ..... 1-1  
Features ..... 1-2  
Software Compatibility ..... 1-2

**Configuring the LX30WB** ..... 2-1  
Static Electricity ..... 2-1  
Office Environment ..... 2-1  
LX30WB Components ..... 2-2  
Jumper Settings ..... 2-3

## Installing the LX30WB, System Memory, CPUs and

**Peripherals** ..... 3-1  
Installation of the LX30WB ..... 3-2  
    Tools Required ..... 3-2  
    Equipment Required ..... 3-2  
System Memory ..... 3-3  
    SIMMs Supported ..... 3-3  
    Memory Configurations ..... 3-4  
    Installing the SIMMs ..... 3-5  
    Removing SIMMs ..... 3-5  
Installing a CPU ..... 3-5  
Installing Cache Memory ..... 3-6  
Installing a VL-Bus Peripheral Card ..... 3-7

**The BIOS Setup Utility** ..... 4-1  
Configuration ..... 4-1  
Initial Boot Up ..... 4-1  
Setup ..... 4-2  
Running the Setup Procedure ..... 4-2  
Setting the CMOS Parameters ..... 4-3  
Setting the CMOS Main Screen ..... 4-4  
    System Time and Date ..... 4-4

Diskette Drive A or B .....	4-4
Hard-Disk Drive 1-4 (IDE Drives Only) .....	4-4
Base Memory and Extended Memory .....	4-4
Video Card .....	4-4
System Speed .....	4-4
Cache .....	4-4
External Cache Mode .....	4-5
CPU Type .....	4-5
<b>Setting the CMOS Extended Screen .....</b>	<b>4-5</b>
System BIOS .....	4-6
Video BIOS .....	4-6
On Board Floppy .....	4-6
Primary IDE .....	4-6
Master Speed .....	4-6
Slave Speed .....	4-6
Secondary IDE .....	4-6
Serial Port 1 .....	4-6
Serial Port 2 .....	4-6
Parallel Port .....	4-7
Parallel Port Mode .....	4-7
Energy Saving Timer .....	4-7
Non-Cacheable Area .....	4-7
Keyboard .....	4-7
System Password .....	4-7
Setup Password .....	4-8
<b>Re-Configuring Your Computer .....</b>	<b>4-8</b>
<b>POST Messages .....</b>	<b>A-1</b>
<b>Beep Codes .....</b>	<b>B-1</b>
<b>Hard Disk Drive Types .....</b>	<b>C-1</b>
<b>Specifications .....</b>	<b>D-1</b>
Environmental Specifications .....	D-2
Temperature Range .....	D-2
Relative Humidity .....	D-2
Battery Disposal .....	D-3

<b>Installing a Power Module .....</b>	<b>E-1</b>
FCC Warning Statement .....	F-1
Glossary .....	G-1
Limited Warranty .....	W-1
Non-Warranty Service .....	W-2

## List of Figures

Figure 2-1: LX30WB System Board .....	2-2
Figure 3-1: Installing a 72-Pin SIMM .....	3-5
Figure 3-2: Upgrading the External Cache .....	3-6
Figure 3-3: Installing and VL-Bus Card .....	3-7
Figure 4-1: Power-Up Screen .....	4-2
Figure 4-2: CMOS Main Screen .....	4-3
Figure 4-3: CMOS Extended Screen .....	4-5
Figure 4-4: Exit Screen .....	4-9

## List of Tables

Table 2-1: CPU Voltage Requirements .....	2-3
Table 2-2: CPU Selection .....	2-4
Table 2-3: CPU Selection .....	2-4
Table 2-4: External Cache Size Selection .....	2-5
Table 2-5: VL IDE Selection .....	2-5
Table 2-6: VL IDE IRQ14 Selection .....	2-5
Table 2-7: ISA IDE Selection .....	2-5
Table 2-8: Secondary IDE Controller Selection .....	2-6
Table 2-9: Video Selection .....	2-6
Table 2-10: Bus Speed Selection .....	2-6
Table 2-11: Peripheral and Case Connections .....	2-7
Table 3-1: Memory Configurations .....	3-4





# 1 Introduction

The LX30WB is an integrated system board featuring VESA Local Bus architecture and Mode 3 IDE controller (optional). The Micronics LX30WB system board represents Micronics' third generation of VESA Local Bus system boards and makes an excellent foundation for an advanced personal computer or workstation.

Micronics is a forerunner in VESA Local Bus technology. The VESA Local Bus Architecture provides high performance for Graphical User Interfaces (GUIs) and peripherals which perform high speed data transfers, such as disks and multimedia.

The LX30WB is also a "**Green Board**" which means it adheres to the Environmental Protection Agency's strict Energy Star efficiency guidelines. See Chapter 4 for information and instructions on how to set up the "Green Section" of the BIOS.

## Features

The LX30WB includes the following features:

- ⊗ Micronics' X30WB chipset with an external level 2 cache controller.
- ⊗ Two VL-Bus slots.
- ⊗ Three 16-bit and one 8-bit ISA slots.
- ⊗ 100 percent VESA VL-Bus compliant.
- ⊗ Local Bus IDE controller with Mode 3 local bus IDE support (optional).
- ⊗ Floppy controller (Supports 1.44MB, 1.2MB, 720K, and 360K floppy drives).
- ⊗ Two high speed NS16450 compatible serial ports.
- ⊗ Bi-directional parallel port.
- ⊗ Supports the following processors:
  - 486SX, 25 or 33MHz
  - 486SX2, 50MHz
  - 486DX, 33MHz
  - 486DX2, 50 or 66MHz
  - 486DX4, 75 or 100MHz (with optional power module)

## Software Compatibility

The LX30WB system board has been thoroughly tested for compatibility with a variety of operating systems and environments, including:

- ⊗ Windows and Windows NT
- ⊗ OS/2
- ⊗ SCO UNIX and Open Desktop
- ⊗ Novell Netware
- ⊗ MS-DOS
- ⊗ PC-DOS

# 2 Configuring the LX30WB

Although the LX30WB system board is packaged in protective materials, it is important to use care while unpacking and setting up.

## **Static Electricity**

The LX30WB is shipped from the factory in an antistatic bag. To reduce the possibility of damage, it is important to neutralize any accumulated static charges on your body before handling the board. The best way to do this is to ground yourself using a special wrist or ankle strap. If you do not have a strap, you should touch both of your hands to a safely grounded object. After you have grounded yourself, ground the LX30WB via the solder pads surrounding one of its mounting holes.

Once the LX30WB is removed from its packaging, place it on top of the antistatic bag. Carefully inspect the board for damage which may have occurred during shipment.

## **Office Environment**

Make sure the finished computer system is in an area with good ventilation. The system should not be in direct sunlight, near heaters, or exposed to moisture, dust, or dirt.

# LX30WB Components

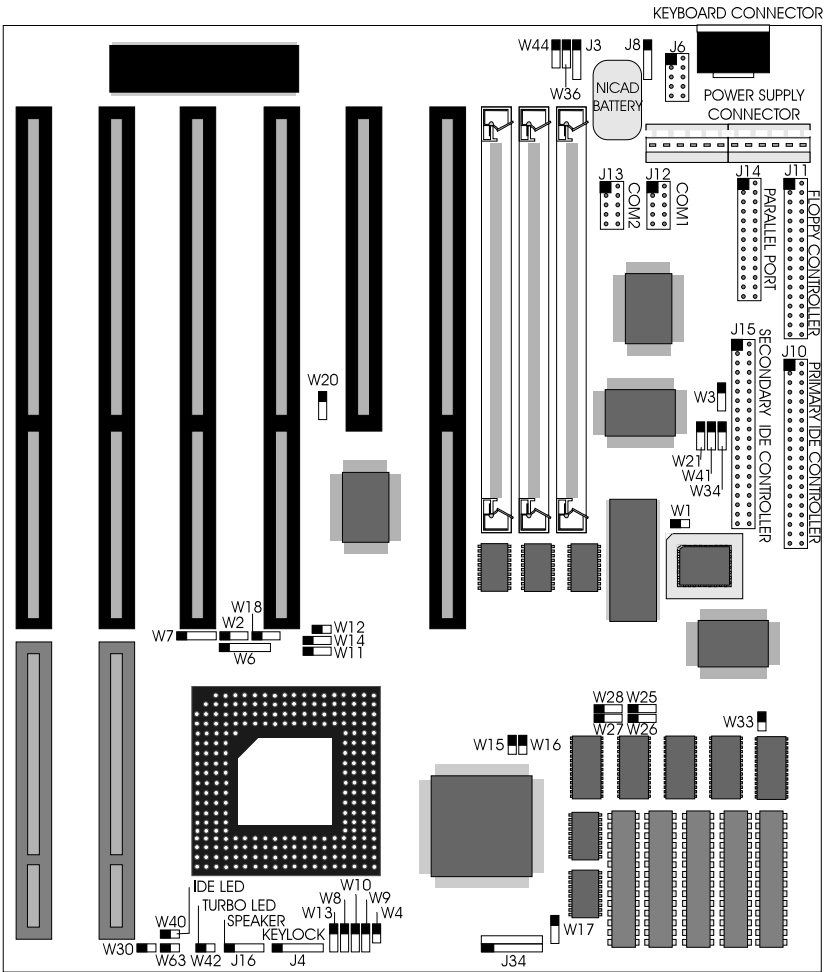

Figure 2-1 LX30WB System Board

Note:

The black square indicates pin one of the component or jumper.

# CPU Voltage

**Warning:**

***This system board has been factory set to support 5.0V processors. If using a 3.3V or 4.0V processor, you must install a Power Module (Appendix E). Failure to install a Power Module could result in damage to the CPU.***

Table 2-1 lists the voltage requirements for CPUs supported by this system board.

CPU	Manufacturer(s)	Voltage
486SX	Intel, AMD	5.0V
486DX	Intel, AMD	5.0V
486DX2	Intel	5.0V
486DX2	AMD	3.3V or 5.0V
486SL-series	Intel	5.0V
Write-Back Enhanced 486DX2	Intel	5.0V
486DX4	Intel, AMD	3.3V
Pentium OverDrive	Intel	5.0V
Cyrix 486DX/DX2	Cyrix	5.0V
Cyrix 486DX2V-80	Cyrix	4.0V

**Table 2-1 CPU Voltage Requirements**

# Jumper Settings

Table 2-2 and 2-3 list the jumper settings to select the type of CPU installed.

CPU	W2	W4	W6	W7	W8	W9	W10
486SX	open	open	4-5	2-3	2-3	1-2	2-3
486DX/DX2 (default)	open	open	4-5	1-2 & 3-4	2-3	1-2	2-3
SL Enhanced SX	1-2	open	4-5	2-3	2-3	1-2	2-3
SL Enhanced DX2	1-2	open	4-5	1-2 & 3-4	2-3	1-2	2-3
Write-Back Enhanced 486DX2	2-3	closed	4-5	1-2 & 3-4	1-2	1-2	1-2
486DX4	open	open	4-5	1-2 & 3-4	2-3	1-2	2-3
Pentium OverDrive	open	open	1-2	1-2 & 3-4	1-2	1-2	1-2
Cyrix 486DX/DX2	open	open	2-3	1-2 & 3-4	2-3	2-3	2-3
AMD 486DXL2	open	open	4-5	1-2 & 3-4	2-3	1-2	2-3
TI 486SXL	open	open	4-5	2-3	2-3	1-2	2-3

**Table 2-2 CPU Selection**

CPU	W11	W12	W13	W14	W17	W18
486SX	3-4	2-3	open	open	2-3	1-2
486DX/DX2 (default)	3-4	2-3	open	3-4	2-3	1-2
SL Enhanced SX	3-4	2-3	open	open	2-3	1-2
SL Enhanced DX2	3-4	2-3	open	3-4	2-3	1-2
Write-Back Enhanced 486DX2	1-2 & 3-4	2-3	open	3-4	1-2	1-2
486DX4	3-4	2-3	3.0X CLK open 2.5X CLK 1-2 2.0X CLK 2-3	3-4	2-3	1-2
Pentium OverDrive	3-4	2-3	open	2-3	1-2	1-2
Cyrix 486DX/DX2	2-3	1-2	open	3-4	1-2	2-3
AMD 486DXL2	3-4	2-3	open	3-4	2-3	1-2
TI 486SXL	3-4	2-3	open	1-2	2-3	1-2

**Table 2-3 CPU Selection**

Table 2-4 lists the jumper settings to select the size of the external cache.

Size	W25	W26	W27	W28
128K	1-2	1-2	1-2	1-2
256K	2-3	2-3	2-3	2-3

**Table 2-4 External Cache Size Selection**

Table 2-5 lists the jumper settings to enable or disable the optional VL IDE controller.

Jumper	Function	Setting
W33	Enable VL IDE controller (default)	open
	Disable VL IDE controller	close

**Table 2-5 VL IDE Selection**

Table 2-6 lists the jumper settings to set the VL IDE hard disk controller's IRQ. Leave this set to IRQ14 unless you are using a SCSI controller and need to free up an unnecessary IRQ, or if you want to use the ISA IDE controller as the primary IDE controller.

Jumper	Function	Setting
W34	IRQ14 (default)	1-2
	IRQ15	2-3

**Table 2-6 VL IDE IRQ14 Selection**

Table 2-7 lists the jumper settings to enable or disable the ISA IDE controller.

Jumper	Function	Setting
W37	Enable ISA IDE controller (default)	2-3
	Disable ISA IDE controller	1-2

**Table 2-7 ISA IDE Selection**

Table 2-8 lists the jumper settings to set the secondary IDE controller's IRQ. If you set this for IRQ14, you must disable the VL IDE controller (Table 2-4).

Jumper	Function	Setting
W41	IRQ15 (default)	1-2
	IRQ14	2-3

**Table 2-8 Secondary IDE Controller IRQ Selection**

Table 2-9 lists the jumper settings to select the type of video installed.

Jumper	Function	Setting
W32	Color monitor (default)	close
	Monochrome monitor	open

**Table 2-9 Video Selection**

Table 2-10 lists the jumper settings to select the bus speed.

Speed	W15	W16
33MHz (default)	close	close
50MHz	close	open
40MHz	open	close
25MHz	open	open

**Table 2-10 Bus Speed Selection**



Table 2-11 lists the jumper settings for case and peripheral connections.

Jumper	Function	Notes
J10	VL IDE Connector	Primary
J15	ISA IDE Connector	Secondary
J11	Floppy Connector	
J14	Parallel Port Connector	Can be disabled in CMOS.
J12	Serial Port (Com 1)	Can be disabled in CMOS.
J13	Serial Port (Com 2)	Can be disabled in CMOS.
J9	AT Keyboard	
J1 & J2	Power Supply Connector	
W43	Turbo LED	1-5V DC; 2- Ground
W42	Turbo Switch	
W30	Reset	
W40	IDE LED	1-5V DC; 2- Ground
J4	Keylock/ Power LED	1-Power; 2-N/C; 3-Ground; 4-5V DC
J16	Speaker Connector	1-Speaker; 2-N/C; 3-Ground; 4-5V DC

**Table 2-11 Peripheral and Case Connections**



# 3 Installing the LX30WB, System Memory, CPUs and Peripherals

This section explains how to install the LX30WB system board, SIMMs, CPUs, and peripherals.

**Warning:**

***Before installing or removing any peripherals or components, make sure you have a clear work space and that you adhere to all anti-static precautions described on page 2-1. Micronics recommends that only trained technicians operate on the system board. Damage which occurs to the board while adding or removing peripherals or components may void the warranty.***

***If problems arise while installing peripherals, contact the computer outlet where you purchased the peripheral or Micronics' Technical Support Department.***

## Installation of the LX30WB

The installation of the LX30WB system board depends on the type of case you use. The LX30WB is a Mini AT system board and can be installed in most cases.

Prior to installing the LX30WB, make sure you have a clear work space available and adhere to all anti-static precautions.

If you are unfamiliar with installing a system board, Micronics highly recommends you read the computer user's manual or contact your dealer's technical support department.

### Tools Required

Micronics recommends using the following tools to install the LX30WB:

- ⊗ Small Phillips screwdriver.
- ⊗ Tweezers or a pair of needle-nose pliers.
- ⊗ Tray (to hold loose screws).

### Equipment Required

Micronics recommends using the following equipment with the LX30WB for a typical configuration:

- ⊗ Chassis with standard hardware.
- ⊗ A high quality power supply capable of providing continuous power within a 5 volt range, plus or minus 5% (eg., 4.75 to 5.25). A power filter may be used with a noisy AC power source..
- ⊗ AT-compatible keyboard.
- ⊗ Eight ohm speaker.
- ⊗ Standard ribbon cables for internal connections.
- ⊗ Standard power cord (grounded).
- ⊗ Heat sink with cooling fan.

# System Memory

System memory devices, commonly known as SIMMs (Single Inline Memory Modules), are necessary to operate the LX30WB system board. The LX30WB has three SIMM sockets and can be upgraded to 96 Megabytes of RAM. This section will explain the type of SIMMs supported, list the memory configurations supported, and show how to physically install the new SIMMs.

## **SIMMs Supported**

The LX30WB supports the following 72 pin, 60 or 70ns SIMMs:

4MB (1Mx36 or 1Mx32)

8MB (2Mx36 or 2Mx32)

16MB (4Mx36 or 4Mx32)

32MB (8Mx36 or 8Mx32)

*Note:*

*For long term reliability, Micronics recommends using SIMMs with tin-plated contacts. The use of gold-plated contacts may conflict with the tin alloy of the SIMM socket.*

## Memory Configurations

The following table (Figure 3-1) lists the memory configurations supported.

Bank 0	Bank 1	Bank 2	Total
4MB			4MB
8MB			8MB
4MB	4MB		8MB
4MB	8MB		12MB
4MB	4MB	4MB	12MB
16MB			16MB
8MB	8MB		16MB
4MB	4MB	8MB	16MB
4MB	16MB		20MB
4MB	8MB	8MB	20MB
8MB	8MB	8MB	24MB
8MB	16MB		24MB
4MB	4MB	16MB	24MB
4MB	8MB	16MB	28MB
32MB			32MB
16MB	16MB		32MB
8MB	8MB	16MB	32MB
4MB	16MB	16MB	36MB
8MB	16MB	16MB	40MB
16MB	16MB	16MB	48MB
16MB	32MB		48MB
32MB	32MB		64MB
16MB	16MB	32MB	64MB
16MB	32MB	32MB	80MB
32MB	32MB	32MB	96MB

**Table 3-1 Memory Configurations**

## Installing the SIMMs

To install the SIMMs, locate the memory banks on the system board. Find the lowest bank number available (0, 1, 2) and work your way up.

Perform the following steps to install the SIMMs:

1. Hold the SIMM so that the notched edge is aligned with the notch on the SIMM socket (Figure 3-1).
2. Insert the SIMM at a 45 degree angle.
3. Gently push the SIMM into an upright position until it “snaps” into place (past the release tabs).

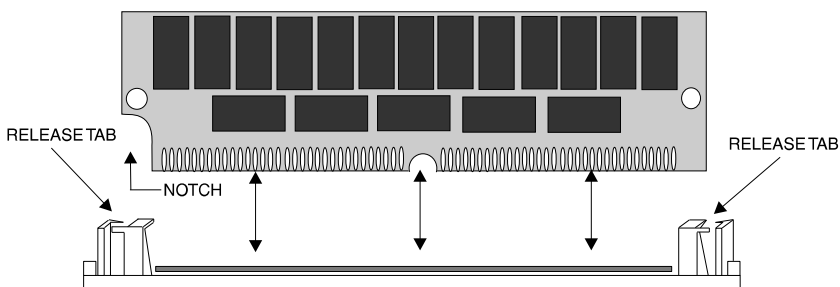

Figure 3-1 Installing a 72-Pin SIMM

## Removing SIMMs

Perform the following steps to remove SIMMs, if necessary:

1. With both thumbs (or fingers), press the release tabs away from the socket.
2. With the SIMM free from the release tabs, lift the module up and place in an anti-static bag or package.

## Installing a CPU

The LX30WB is designed to support a large variety of 486 processors. If you want to upgrade your processor, it is recommended you bring your system and this manual to your local dealer or a qualified repair center.

# Installing Cache Memory

In addition to the internal (L1) cache built into the CPU, the LX30WB also supports external (L2) cache. The LX30WB is available with 128K or 256K external cache.

To upgrade to 256K cache, install five 32Kx8-15ns SRAMs into the open SRAM sockets (Figure 3-2). After installing the cache upgrade, refer to Table 2-4 for the correct external cache jumper settings.

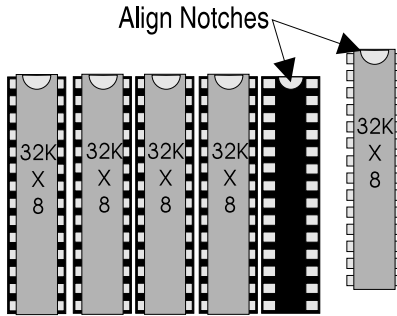

**Figure 3-2 Upgrading the External Cache**



# Installing a VL-Bus Peripheral Card

Micronics VL-Bus slots accommodate all VL-Bus cards which meet the VESA specifications. Complete the following steps to install a VL-Bus card:

1. Turn the computer system off and remove the cover.
2. Choose an unused VL-Bus slot and remove the slot cover.
3. Insert the card with the bottom edge level to the slot. **Never insert the card at an angle!**
4. Carefully push the card straight down, making sure the card is fully inserted.
5. Replace the screw which holds the card into place.
6. Replace the computer cover.
7. Read the card's manual for additional instructions concerning installation and software drivers.

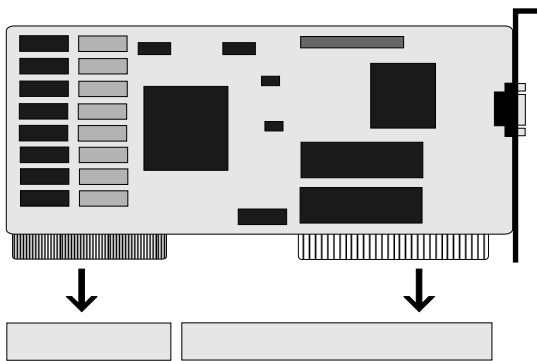

Figure 3-3 Installing a VL-Bus Card



# 4 The BIOS Setup Utility

## Configuration

After the LX30WB system board and all hardware is installed, the system is ready for configuration. Before turning on the computer, make sure all cables are correctly connected and all jumpers are correctly set.

It is recommended you keep the computer cover off the first time you boot the system. If you have any difficulties, they will be easier to correct.

## Initial Boot Up

Power up the LX30WB. If the system doesn't properly boot, check all your cables and peripherals for bad connections. You may also get error messages or beep codes. If this occurs, consult Appendices A and/or B for a guide to possible solutions.

After the system properly boots, it is ready to be configured. The following pages explain the proper procedures for BIOS configuration.

# Setup

The Setup procedure is built into the system. Setup begins after the completed system is powered up. Once the system is powered up and goes through a memory test, the following screen appears on your monitor:

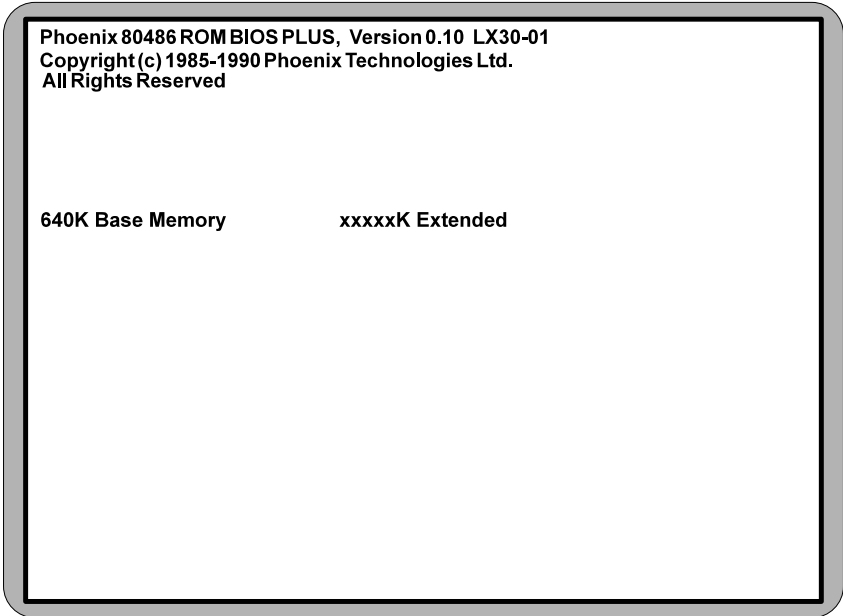

**Figure 4-1 Power-Up Screen**

If the systems detects a configuration error, it displays an error message. After the error message, another message displays indicating the choice to “press <F1> to continue (boot up), or <F2> to run the Setup procedure.” Normally, you will press <Ctrl>, <Alt>, and <Esc> simultaneously to begin the Setup procedure.

## Running the Setup Procedure

Upon pressing <F2>, the CMOS Main Screen (Figure 4-2) should appear and the prompt should be on the time line. If the Power-Up Screen does not appear but a DOS prompt does (i.e., A:\ or C:\), press the <Ctrl>, <Alt>, and <Esc> keys simultaneously to begin the Setup procedure.

The LX30WB system board has two CMOS configuration screens: the Main Screen (Figure 4-2) and the Extended Screen (Figure 4-3). To toggle between the screens, press the PgUp/PgDn keys.

Phoenix SETUP Utility (Version 1.00)					
(c) Phoenix Technologies Ltd. 1985, 1993 All Rights Reserved					
					Page 1 of 2
System Time:	[HH:MM:SS]	System Date:	[MM/DD/YYYY]		
Diskette Drive A:	3.5", 1.44MB				
Diskette Drive B:	Not Installed				
Hard-Disk Drive 1:	Auto Config				
Hard-Disk Drive 2:	Not Installed				
Hard-Disk Drive 3:	Not Installed	Cyl	Hd	Pre	LZ
Hard-Disk Drive 4:	Not Installed	xxx	xx	xxx	xxx
		Sec	Size		
		xx	xxx		
Base Memory:	640KB				
Extended Memory:	XXX KB				
Video Card:	VGA/EGA				
System Speed:	Normal				
Cache:	Both				
Ext. Cache Mode:	Write-Back				
CPU Type:	XXXXXX				
Esc	F1	F2	↑↓	+/-	PgUp/
Menu	Help	Sys Info	Field	Value	PgDn

Figure 4-2 CMOS Main Screen

Now, configure the parameters to match your specific requirements. See the following pages for procedures on how to set the computer's parameters.

To return to the CMOS configuration screens at any time to change or view any of these parameters, press <Ctrl>, <Alt>, and <Esc> simultaneously.

## Setting the CMOS Parameters

Before running the computer, certain parameters on the CMOS configuration screens must be set so the computer properly operates. First, set the parameters on the CMOS Main Screen, then press the PgUp/PgDn key, and set the parameters on the CMOS Extended Screen.

*Note:*

*Some of the parameters are already set and should not be changed. Only change the settings if necessary.*

## Setting the CMOS Main Screen

### System Time and Date

To set the time, use the minus <-> key to decrease the number and the plus <+> key to increase the number. To move the prompt forward, use the right arrow <-> key; to move the prompt backward, use the left arrow <-> key. Follow the same procedure for the date.

### Diskette Drive A or B

This allows you to configure a diskette drive added or removed from your computer. Use the <+/-> keys to toggle between the options.

### Hard-Disk Drive 1-4 (IDE Drives Only)

This selection allows you to configure a hard disk installed in your system. Use the <+/-> keys to toggle between the options. See Appendix C for a complete listing of all possible hard drive types.

To install most SCSI hard drives, select NOT INSTALLED. To manually configure the hard drive, select USER CONFIG. Press the down arrow <↓> key and type in the appropriate parameters. To automatically configure an IDE hard drive, select AUTO CONFIG. Drives that can be Auto-Configured report parameters to the BIOS.

### Base Memory and Extended Memory

Both of these memory settings are automatically configured. Press the down arrow <↓> key to move to the next selection.

## **Video Card**

This sets the type of monitor required for your computer. The display peripheral supports VGA/EGA, CGA80, CGA40, Monochrome (MONO), or no monitor at all. Use the <+/-> keys to toggle between the options.

## **System Speed**

This parameter selects two speeds on the computer. When set to NORMAL, the system operates at full speed. When set to SLOW, it runs at about half of the normal speed.

## **Cache**

This category allows you to enable both the internal and the external cache, enable the internal cache only, or disable both caches. For optimal performance, select BOTH.

## **External Cache Mode**

This selection sets the secondary cache scheme. Setting the scheme to WRITE-BACK and placing jumper blocks on W16 and W17 will improve performance up to 4%. Refer to Tables 2-7 and 2-10 for cache jumper configuration.

## **CPU Type**

This option lists the CPU installed.

# Setting the CMOS Extended Screen

You can toggle between the Main screen and the Extended screen (Figure 4-3) using the PgUp and PgDn key.

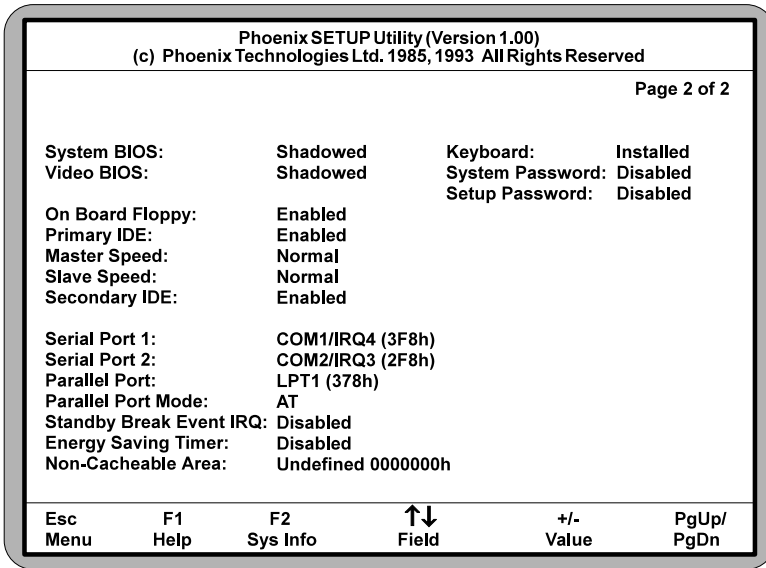

Figure 4-3 CMOS Extended Screen

## System BIOS

The System BIOS Option allows you to Shadow, Shadow & Cache, or Disable the BIOS Shadow on the system board. Choosing SHADOWED copies the system's BIOS into RAM for faster execution. Choosing SHADOWED & CACHED caches the shadowed system BIOS for even higher performance. This allows you to take advantage of the high-speed 32-bit bus and the 70 nanosecond RAM. Use the <+/-> key to toggle between the options.

## Video BIOS

The Video BIOS Option allows you to Shadow, Shadow & Cache, or Disable the BIOS Shadow on the system board. Choosing SHADOWED copies the system's video BIOS into RAM for faster execution. Choosing SHADOWED & CACHED caches the shadowed video BIOS for even higher performance. Use the <+/-> key to toggle between the options. The System BIOS Shadow option must be set to SHADOW or SHADOW & CACHE before enabling the Video BIOS Shadow options.



## **On Board Floppy**

The On Board Floppy controller can be set to ENABLED or DISABLED.

## **Primary IDE**

The VL-Bus IDE controller can be set to ENABLED or DISABLED.

## **Master Speed**

The speed can be set for NORMAL, MEDIUM, or FAST. To improve the performance of your system, see the manufacturer's specifications to determine the optimal setting. The default setting is NORMAL.

## **Slave Speed**

The speed can be set for NORMAL, MEDIUM, or FAST. To improve the performance of your system, see the manufacturer's specifications to determine the optimal setting. The default setting is NORMAL.

## **Secondary IDE**

The ISA IDE controller can be set to ENABLED or DISABLED.

## **Serial Port 1**

Serial Port 1 may be set for COM1 (default), COM3, or may be disabled. Be sure this setting does not conflict with any other peripherals.

## **Serial Port 2**

Serial Port 2 may be set for COM2 (default), COM4, or may be disabled. Be sure this setting does not conflict with any other peripherals.

## **Parallel Port**

The parallel port may be set for LPT1 (default), LPT2, or may be disabled. Be sure this setting does not conflict with any other peripherals.

## **Parallel Port Mode**

The parallel port may be set for AT mode (output only), PS/2 mode (bidirectional), or may be disabled.

## **Energy Saving Timer**

The Energy Saving Timer conserves energy by putting the system into a "sleep mode." When the system is in sleep mode, it consumes less energy.

If a specified time elapses and no keystrokes or mouse movements are performed, the computer goes into sleep mode. This category can be set for one minute or in increments of fifteen minutes (up to 120 minutes). After the

allotted time, the CPU will stop. To return to full processing speed, press any key.

## Non-Cacheable Area

This category allows a block of 32-bit memory to be set as NON-CACHEABLE. The size and address can be selected. The sizes include: 64K, 128K, 256K, 512K, 1M, 2M, and 4M.

To select the memory to be Non-Cacheable, use the <+/-> keys to change the first three zeros to the appropriate address (only these zeros can be changed). It must start from 0000000h to 0FF0000h (15.94MB). The default setting for this category is UNDEFINED.

## Keyboard

If the keyboard category is set to INSTALLED, the computer will test the keyboard during boot. If set for NOT INSTALLED, the system will ignore any keyboard errors and always attempt to boot. Set this for INSTALLED unless using the system board in an application which does not require a keyboard.

## System Password

When enabled, a password will be required to enter the system.

To set a system password, set this category to ENABLED. After you have finished configuring the BIOS, press the <Esc> key to exit followed by the <F4> key to save the changes and reboot. When the system reboots, it will ask you to enter a new password. After you enter the new password, the System Password feature will be in effect.

### ***Warning:***

***If you forget your password, it cannot be changed without discharging the CMOS.***

## Setup Password

When enabled, a password will be required to enter Setup.

To activate the Setup Password, set this category to ENABLED. After you have finished configuring the BIOS, press the <Esc> key to exit followed by the <F4> key to save the changes and reboot. After the system reboots, press <Ctrl>, <Alt>, and <Esc> simultaneously to re-enter the setup program. On re-entering the Setup program, you will be asked to enter a new password. After you enter the new password, the Setup Password feature will be in effect.

# Re-Configuring Your Computer

Press the <Esc> key to reach the Exit Pop-Up Screen. Now select <F4> to save and initialize the new Setup.

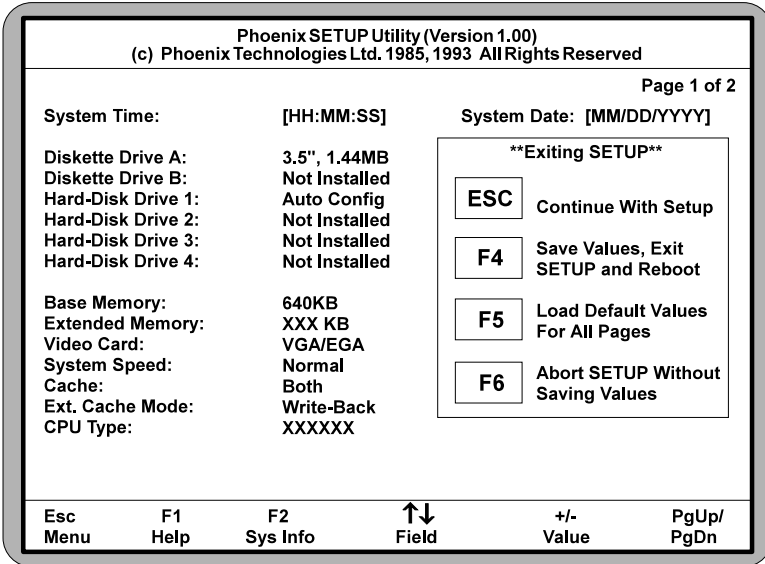

Figure 4-4 Exit Pop-up Screen



# A POST Messages

The following table lists the Power On Self Test (POST) messages, possible causes, and solutions.

Message	Possible Cause	Solution
NO DISKETTE CONTROLLER	Disk controller not found.	Change the Configuration.
DISKETTE DRIVE RESET FAILED	Disk adapter has failed or is improperly configured.	Check the disk adapter.
DISKETTE DRIVE A FAILURE	Drive A failed or is missing.	Check the A drive.
DISKETTE DRIVE B FAILURE	Drive B failed or is missing.	Check the B drive.
DISKETTE READ FAILURE; STRIKE F1 TO RETRY BOOT	Disk is not formatted or is defective.	Replace the diskette with a formatted diskette and retry.
DISPLAY ADAPTER FAILED USING ALTERNATE	The color/monochrome switch is not set correctly, or the primary video adapter failed.	Change the switch to the correct setting, or check the primary video adapter.
ERRORS FOUND; DISK X FAILED INITIALIZATION	Hard disk configuration information is incorrect.	Rerun SETUP and enter the correct hard disk information.
ERRORS FOUND; INCORRECT CONFIGURATION INFORMATION; MEMORY SIZE MISCOMPARE	The size of the base or the expansion memory, does not agree with configuration information.	Enter correct memory size and rerun SETUP procedure.

<b>Message</b>	<b>Possible Cause</b>	<b>Solution</b>
FIXED DISK CONFIGURATION FAILURE	The specified configuration is not supported.	Correct the hard disk configuration.
FIXED DISK CONTROLLER FAILURE	The controller card has failed.	Replace controller card.
FIXED DISK X FAILURE (where X =0 or 1)	The hard disk crashed.	Press F1 to reboot or rerun SETUP. If this does not work, replace hard disk.
HARD READ FAILURE- STRIKE F1 TO RETRY BOOT	The hard disk failed.	Press F1 to reboot or rerun Setup. If this does not work, replace hard disk.
FDD CONTROLLER FAILURE	Diskette controller failed.	Replace controller card.
FDD A IS NOT INSTALLED	Cannot find diskette controller for drive A.	Install or replace controller card.
FDD B IS NOT INSTALLED	Cannot find diskette controller for drive B.	Install or replace controller card.
KEYBOARD CLOCK LINE FAILURE or KEYBOARD DATA LINE FAILURE	Keyboard logic failed.	Make sure the keyboard cable is connected correctly.
KEYBOARD STUCK KEY FAILURE	A key is jammed or was held down during boot.	Make sure the keys are not jammed or dirty.
REAL TIME CLOCK FAILURE	The real-time clock logic failed.	Check battery and replace, if necessary
TIME-OF-DAY NOT SET- RUN SETUP PROGRAM	The real-time clock time-of-day is not running.	Run SETUP utility.
BIOS XXXX ROM BAD CHECKSUM (where XXXX=C8000 to E0000)	The optional ROM checksum is bad.	Replace add-on card.

Message	Possible Cause	Solution
DISKETTE READ FAILURE, or NOT A BOOT DISKETTE, or NO BOOT DEVICE AVAILABLE	Hard/floppy disk failed or is not bootable.	Replace the diskette with a bootable diskette and retry.
DECREASING AVAILABLE MEMORY, or MEMORY FAILURE AT AAAAAAAA READ XXXX EXPECTING YYYY (where AAAAAAAA = failing address, XXXX=data read, and YYYY=data written)	The memory data integrity failed.	Check contact points between memory modules and system board. Replace memory modules if necessary.

# B Beep Codes

Beep codes are a series of beeps sent through the speaker which indicate a problem during the Power On Self Test (POST). If text appears on the video screen, the LX30WB has completed POST; any other tone from the speaker indicates something other than a POST error. These tones **are not** described in Table B-1.

The beep error codes are a series of three sets of beeps. The duration of the beep tones are constant, but the length of the pauses between the beeps varies. For example: a 1-3-3 beep code will sound like one beep, a pause; three beeps consecutively, another pause; and then three more beeps.

One beep code is often misunderstood. If a video card is not installed or is failing, the system board will generate a long-short-long-short beep code. This is often interpreted as a 1-2-1 beep code. But POST errors always vary in the length of the pause and not the duration of the beep tone.

Another way of identifying a POST error is to use a device called a POST card. This peripheral card is inserted into one of the ISA slots and has an LED (or LCD) read out showing the contents of port 80h.

The following table provides a list of all beep codes and probable causes.



<b>Beep code</b>	<b>Contents Port 80h</b>	<b>Description</b>
None	01h	CPU register test in progress.
1-1-3	02h	CMOS read/write failure.
1-1-4	03h	ROM BIOS check failure.
1-2-1	04h	Programmable interval timer failure.
1-2-2	05h	DMA initialization failure.
1-2-3	06h	DMA page register write/read failure.
1-3-1	08h	RAM refresh verification failure.
None	09h	First 64K RAM test in progress.
1-3-3	0Ah	First 64K RAM chip or data line failure (multi-bit).
1-3-4	0Bh	First 64K RAM odd/even logic failure.
1-4-1	0Ch	Address line failure first 64K RAM.
1-4-2	0Dh	Parity failure first 64K RAM.
2-1-1	10h	Bit 0 first 64K RAM failure.
2-1-2	11h	Bit 1 first 64K RAM failure.
2-1-3	12h	Bit 2 first 64K RAM failure.
2-1-4	13h	Bit 3 first 64K RAM failure.
2-2-1	14h	Bit 4 first 64K RAM failure.
2-2-2	15h	Bit 5 first 64K RAM failure.
2-2-3	16h	Bit 6 first 64K RAM failure.
2-2-4	17h	Bit 7 first 64K RAM failure.
2-3-1	18h	Bit 8 first 64K RAM failure.
2-3-2	19h	Bit 9 first 64K RAM failure.
2-3-3	1Ah	Bit 10 first 64K RAM failure.
2-2-4	1Bh	Bit 11 first 64K RAM failure.
2-3-1	1Ch	Bit 12 first 64K RAM failure.
2-4-2	1Dh	Bit 13 first 64K RAM failure.

Beep code	Contents Port 80h	Description
2-4-3	1Eh	Bit 14 first 64K RAM failure.
2-4-4	1Fh	Bit 15 first 64K RAM failure.
3-1-1	20h	Slave DMA register failure.
3-1-2	21h	Master DMA register failure.
3-1-3	22h	Master interrupt mask register failure.
3-1-4	23h	Slave interrupt mask register failure.
None	25h	Interrupt vector loading in progress.
3-2-4	27h	Keyboard controller test failure.
None	28h	CMOS power failure and checks calculation in progress.
None	29h	CMOS configuration validation in progress.
3-3-4	2Bh	Screen initialization failure.
3-4-1	2Ch	Screen retrace test failure.
3-4-2	2Dh	Search for video ROM in progress.
None	2Eh	Screen running with video ROM.
None	30h	Screen operable.
None	30h	Screen running with video ROM.
None	31h	Monochrome monitor operable.
None	32h	Color monitor (40 column) operable.
None	33h	Color monitor (80 column) operable.

Code	Beeps	POST Routine Description
9C		Set up Power Management.
9E		Enable hardware interrupts.
A0		Set time of day.
A2		Check key lock.
A4		Initialize typematic rate.
A8		Erase F2 prompt.
AA		Scan for F2 keystroke.
AC		Enter SETUP.
AE		Clear in-POST flag.
B0		Check for errors.
B2		POST done - prepare to boot operating system.
B4		One beep.
B6		Check password (optional).
B8		Clear global descriptor table.
BC		Clear parity checkers.
BE		Clear screen (optional).
BF		Check virus and backup reminders.
C0		Try to boot with INT 19.
D0		Interrupt handler error.
D2		Unknown interrupt error.
D4		Pending Interrupt.
D6		Initialize option ROM error.
D8		Shutdown error.
DA		Extended Block Move.
DC		Shutdown 10 error.
		The following are for boot block in Flash ROM:
E2		Initialize the chipset.
E3		Initialize refresh counter.
E4		Check for Forced Flash.
E5		Check HW status of ROM.
E6		BIOS ROM is OK.
E7		Do a complete RAM test.
E8		Do OEM initialization.
E9		Initialize interrupt controller.
EA		Read in the bootstrap code.
EB		Initialize all vectors.
EC		Boot the Flash program.
ED		Initialize the boot device.
EE		Boot code was read OK.

# C Hard Disk Drive Types

The following table lists the hard disk types supported by LX30WB.

Type	Cyl	Hd	Pre	Sec	Size
1	306	4	128	17	10
2	615	4	300	17	21
3	615	6	300	17	30
4	940	8	512	17	62
5	940	6	512	17	46
6	615	4	-1	17	20
7	462	8	256	17	30
8	733	5	-1	17	30
9	900	15	-1	17	112
10	820	3	-1	17	20
11	855	5	-1	17	35
12	855	7	-1	17	49
13	306	8	128	17	20
14	733	7	-1	17	42
15	N/A	N/A	N/A	N/A	N/A
16	612	4	0	17	20
17	977	5	300	17	40
18	977	7	-1	17	56
19	1024	7	512	17	59
20	733	5	300	17	30
21	733	7	300	17	42

Type	Cyl	Hd	Pre	Sec	Size
22	733	5	300	17	30
23	762	8	-1	17	116
24	830	10	-1	39	68
25	1024	9	-1	17	76
26	918	7	-1	17	53
27	1024	8	-1	17	68
28	903	8	-1	46	162
29	1024	4	-1	17	34
30	820	6	-1	17	40
31	969	9	-1	34	144
32	615	8	-1	17	40
33	1024	5	-1	17	42
34	940	16	-1	26	190
35	1010	12	-1	55	325
36	903	4	-1	46	81
37	901	5	-1	53	116
38	980	5	128	17	40
39	966	16	-1	17	128
40	723	13	-1	51	234
41	1024	16	-1	63	504
42	966	5	-1	34	80
43	965	10	-1	17	80
44	776	8	-1	33	100
45	654	16	-1	63	321
46	683	16	-1	30	202
47	755	16	-1	17	100
User Config					
Auto Config					

# D Specifications

Processor Options	Intel 486 SX 25 & 33MHz, PQFP. Intel 486 DX 33MHz, PGA. Intel 486 DX2 50 & 66MHz, PGA. Intel 486DX4 75 & 100MHz. Intel 486 DX2 3.3V Support. Intel Pentium <i>OverDrive</i> Processor. 486 OverDrive Processor.
Expansion	Two VL-Bus slots. Three 16-bit ISA slots. One 8-bit ISA slot.
Chip Set	Micronics X30 single chip ASIC. CMD 640A Local bus IDE (optional). Winbond super I/O controller.
RAM Capacity	96MB.
Form Factor	Mini AT footprint (8.5" x 13"). 4 Layer PCB.
Keyboard	Standard AT keyboard support.
BIOS	Phoenix BIOS on 512K EPROM.
Cache	8K of internal cache memory (may vary).
Cache Upgrade	Optional 128K, or 256K of secondary cache memory (write-through or write-back).
I/O Ports	Built in support. Two high speed serial ports (16450 compatible). One bi-directional parallel port. Enhanced Parallel Port (EPP) compatible (optional). Microsoft and Hewlett Packard Extended Capabilities Port (ECP) compatible (optional).

Floppy Port	Supports two floppy drive (1.44, 1.2, 720K, 360K).
VL-Bus IDE Port	Supports two IDE hard disks. Mode 3 support. Multiple sector transfer support. LBA support.
Secondary IDE Support	Supports two additional IDE hard disks. Multiple sector transfer support. LBA support.
Burn-in	48 hours (minimum).

## Environmental Specifications

The environment in which the LX30WB is located is critical. Micronics recommends the following environmental specifications:

### Temperature Range

Operating: 50 to 104 degrees Fahrenheit (10 to 50 degrees Celsius).

Non-Operating: 50 to 140 degrees Fahrenheit (10 to 60 degrees Celsius).

Shipping: -22 to 140 degrees Fahrenheit (-30 to 60 degrees Celsius).

### Relative Humidity

Operating: 20% to 80%

Non-Operating: 5% to 90%

# Battery Disposal

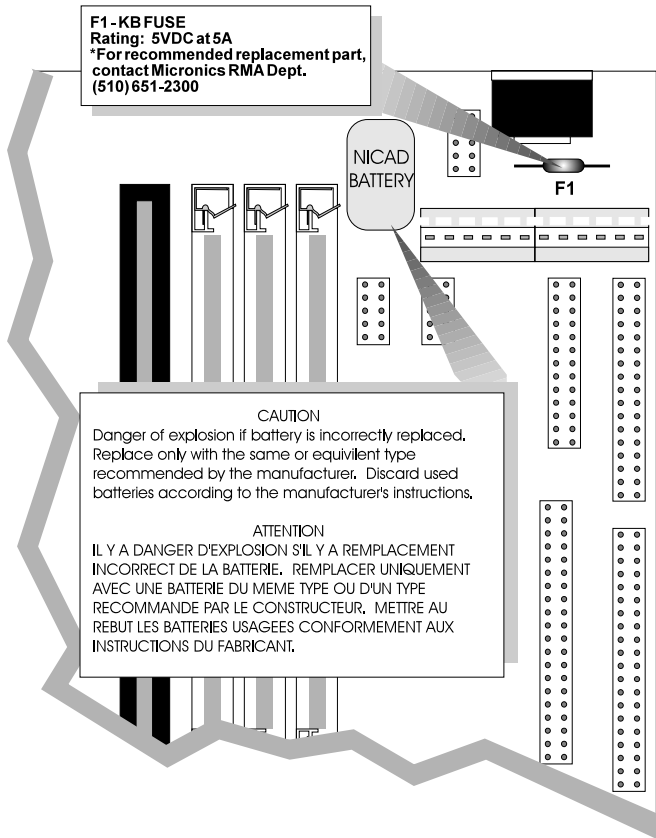

**Warning:**

**DO NOT:** open battery; dispose of in fire; recharge; put in backwards, mix with used or other battery types.

**May explode or leak and cause personal injury.**





# E Installing a Power Module

The LPM30 will accommodate a large variety of 486 processors. When installing a 5.0V processor, locate J34 on your system board (see Figure 2-1) and configure it as shown below (Figure E-1).



Figure E-1 Configuring Jumper J34

To configure your system board for a 3.3V or 4.0V processor, you will need to order a Power Module. If you do not have one, contact Micronics' Customer Service department at (510) 651-2300.

To install a Power Module, remove all jumpers from Jumper J34 and install it as shown below (Figure E-2 and E3).

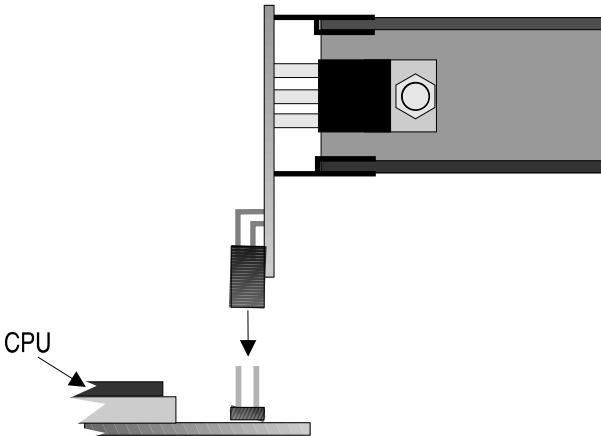
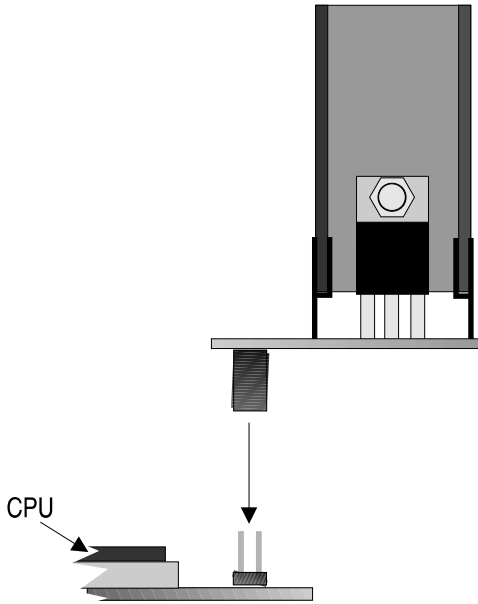
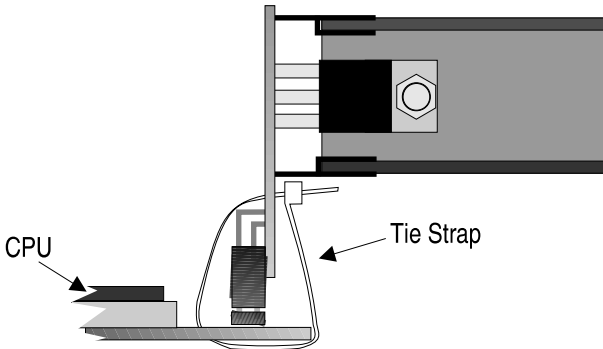

Figure E-2 Installing a Power Module (Part # 09-00225-01)



**Figure E-3 Installing a Power Module (Part # 09-00225-02)**

After you have installed the Power Module, secure it with a tie strap (Figure E-4 and E-5) and your installation is complete.



**Figure E-4 Securing the Power Module (Part # 09-00225-01)**

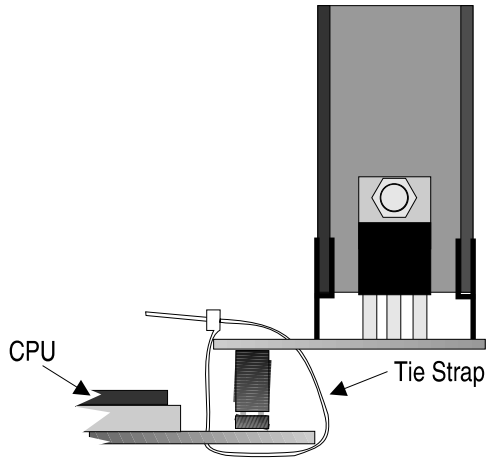

Figure E-5 Securing the Power Module (Part # 09-00225-02)

# FCC Warning Statement

This equipment has been tested and found to comply within the limits for a Class B digital device, pursuant to Part 15 of the FCC Rules. These limits are designed to provide reasonable protection against harmful interference in a residential installation. This equipment generates, uses and can radiate radio frequency energy and, if not used in accordance with the instructions, may cause harmful interference to radio communications. Interference to radio or television reception can be determined by turning the equipment off and on. The user is encouraged to try to correct the interference by one or more of the following measures:

- Ⓜ Reorient the receiving antenna.
- Ⓜ Increase the separation between the equipment and the receiver.
- Ⓜ Connect the equipment into an outlet on a circuit different from that to which the receiver is connected.
- Ⓜ Consult your dealer or an experienced radio/TV technician for help.

To meet FCC requirements, shielded cables and power cords are required.

*Note:*

*Changes or modifications not expressly approved by Micronics could void the user's authority to operate the equipment.*

# Glossary

- 16550 UART** - A high speed chip for controlling serial ports. Although unnecessary for a mouse, it is required for modems that are 14,400 baud or faster.
- 486DX** - A type of 32-bit CPU with a built in math-coprocessor and internal cache.
- 486DX2** - A 486DX CPU where the internal speed of the CPU operates at twice the external speed.
- 486DX4** - A 486DX CPU where the internal speed of the CPU operates at three times the external speed.
- 486SX** - A 486DX CPU with no math-coprocessor.
- Asynchronous** - Operations that do not require the clocks of communicating devices to be coordinated. See Synchronous.
- Baby AT** - A standard system board size measuring approximately 13.25" x 8.5".
- Bidirectional Parallel Port** - A type of parallel port that can send and receive information.
- BIOS** - An Acronym for Basic Input/Output System. Configures the system board and provides hardware information to the operating system.
- Bit** - A contraction of Binary digit. The smallest unit of information in a binary number system. A bit represents a choice between either zero or one.
- Boot** - To start up the computer and load the operating system software. See *cold boot* and *warm boot*.
- Bus** - A group of electronic paths used to send data between parts of the system. On a system board, the bus connects the peripheral cards with the microprocessor via the expansion slots.
- Bus Mastering** - The ability of an peripheral card to control the bus without requiring intervention of the CPU.
- Byte** - A group of adjacent *bits* treated as a unit. Eight bits are typically considered one byte. Also called a character.
- Cache** - A process where information is copied from the slower memory (DRAM) to the faster memory (SRAM). Information that is likely to be read or edited is stored in the cache providing significant performance increases.
- Cache hit** - The percentage of request for data from memory that can be served from the cache.
- Cache miss** - A memory access which cannot be supplied from cache.
- Cold Boot** - Starting the computer by turning on the power or pressing the RESET button. A cold boot makes the processor execute all of the diagnostics. See boot and warm boot.
- CPU** - An acronym for Central Processing Unit. A CPU performs arithmetic calculations, makes logical decisions, and directs the operation of the computer in conjunction with the operating system.
- Disk Drive** - A hardware device which provides for the storage of data on diskettes or hard metal disks that have a magnetic coating. A disk drive functions by spinning at high speed while moving a device called the read/write head across the disk's surface in order to read or write data in magnetic code.
- DRAM** - An acronym for Dynamic Random Access Memory. A type of memory chip that only keeps its memory if supplied with regular clock pulses and a chance to regularly refresh its data. It is slower and more cost effective than SRAM. See SRAM.
- ECP** - An acronym for Expanded Capabilities Port. A standard set by Hewlett Packard and Microsoft Corporation to expand the capabilities of the parallel port.
- EDO Memory** - An acronym for Extended Data Output. A type of DRAM with built-in cache.

**EISA** - An acronym for Extended Industry Standard Architecture. EISA is a bus design standard which is fully backward compatible with the ISA bus. Although it is a 32-bit bus, it only runs at 8MHz. See *PCI, VESA, and ISA*.

**EPP** - An acronym for Enhanced Parallel Port. A standard which increases the capabilities of the parallel port.

**EPROM** - Acronym for Erasable Programmable Read Only Memory. A type of ROM chip that can be programmed with relatively simple tools that will retain its data until erased. It can only be erased by exposing the circuitry in the chip to ultraviolet light. See also Flash ROM.

**External Cache** - Cache which is external to the CPU. See Cache.

**Fast SCSI** - A SCSI data transfer standard that allows a rate of up to 10MB/sec.

**Fast Wide SCSI** - A SCSI data transfer that allows a rate of up to 20MB/sec.

**Flash ROM** - A type of ROM chip that will retain its data until erased. It can be erased or reprogrammed by supplying it with +12V of voltage. See ROM and EPROM.

**Full Size** - A standard system board size measuring approximately 12" x 13.75".

**Gigabyte** - A disk storage capacity measurement. Approximately one thousand megabytes or 1,073,741,824 bytes.

**IDE** - An acronym for Integrated Device Electronics. A standard for communicating between a hard drive and a computer.

**Internal Cache** - Cache which is built into the CPU. See Cache.

**ISA** - An acronym for Industry Standard Architecture. A well-established bus standard that originated with the IBM AT. See *PCI, VESA, and EISA*.

**Jumper** - a small plug that fits over and shorts pins on a circuit board. Jumpers allow the various functions of the board to be enabled or disabled.

**Kilobyte (KB)** - 1,024 bytes.

**L1 Cache** - See Internal Cache.

**L2 Cache** - See External Cache.

**LBA** - An acronym for Logical Block Addressing. Any IDE hard drive that is larger than 528MB.

**Math coprocessor** - A microprocessor designed specifically for performing mathematical calculations. A math coprocessor performs these calculations faster than the CPU, and by doing so, frees the CPU for other activities.

**Megabyte (MB)** - 1,024 Kilobytes or 1,048,576 bytes.

**Mini AT** - A standard system board size measuring approximately 8.5" x 9.5".

**Mode 1** - An IDE data transfer standard that supports transfer rates of up to 5.22 Mbytes/sec.

**Mode 2** - An IDE data transfer standard that supports transfer rates of up to 8.33 Mbytes/sec.

**Mode 3** - An IDE data transfer standard that supports transfer rates of up to 11.1 Mbytes/sec.

**Mode 4** - An IDE data transfer standard that supports transfer rates of up to 15.5 Mbytes/sec.

**Parallel** - A form of data transmission in which the data is sent one byte at a time over several wires that each carry one byte. In parallel transmission, all the bytes arrive simultaneously, as opposed to serial transmission in which bits arrive one by one.

**Parallel Port** - A connection for a printer or similar peripheral. Generally, parallel ports are output only. See Bidirectional Parallel Port and ECP.

**PCI** - An acronym for Peripheral Component Interconnect. A high performance 32-bit or 64-bit bus developed by Intel Corporation. PCI is designed to be independent of the hardware architecture to ensure compatibility with future computer systems. See *VESA, EISA, and ISA*.

**Pentium** - A high performance 64-bit CISC processor designed and manufactured by Intel Corporation. As of this writing, Pentium is the highest performing X86 processor available.

- Plug and Play** - A standard developed to ensure easy installation of peripherals. Theoretically, a newly installed card will automatically configure itself and work properly without requiring jumper configuration or device drivers.
- POST** - An acronym for Power On Self Test. A diagnostic program that is run whenever the system is cold booted.
- RAM** - An acronym for Random Access Memory. A type of memory that is used as the "working memory" of a computer system. See DRAM and SRAM.
- ROM** - An acronym for Read Only Memory. A type of memory that retains its data without requiring power. Once written, it cannot be modified. See EPROM and Flash ROM.
- SCSI** - An acronym for Small Computer Systems Interface. An interface standard used to interface hard disk drives, removable cartridge drives, tape drives, and CD-ROMs to the computer system. SCSI allows multiple, high-performance peripheral devices to be connected in a chain. Each has its own address. Data and control signals are sent along the chain and only the specifically addressed device responds.
- SCSI II** - An interface standard that adds features to the SCSI standard. These include 32-bit data transfer, command queuing, Fast SCSI, and support for a wider variety of peripherals.
- SCSI III** - A proposed standard that will support transfer rates of up to 40MB/sec.
- Serial** - A type of data transmission in which the data is sent one bit at a time over a single wire. See parallel.
- Serial Port** - A communications port used to connect peripherals such as modems and mice.
- Setup** - A program which allows you to make changes to the system configuration.
- Shadow RAM** - A technique used to load a duplicate copy of BIOS from slower ROM into faster RAM. This enhances system performance because it provides higher access speed to the BIOS.
- SIMM** - An acronym for Standard Inline Memory Module. A small printed circuit board containing memory chips.
- SRAM** - An acronym for Static Random Access Memory. A type of memory that can retain data without requiring a regular clock signal. Although they are faster than DRAM, they hold less data and are more expensive.
- Synchronous** - Protocols that require the clocks of communicating machines or devices to be coordinated.
- Synchronous Cache** - A type of cache that uses a clock signal to latch the inputs and the data output. This structure spreads the cache access across two or three cycles while maintaining a bandwidth of one access per cycle. Improves performance by 5-10%.
- Terabyte** - A measurement for very, very large storage capacity. One Terabyte is equivalent one-thousand gigabytes, one-million megabytes, or 1,099,511,627,766 bytes.
- VESA** - An acronym for Video Electronics and Standards Association.
- VESA Localbus (VL-Bus)** - A high performance bus designed by VESA. A 32-bit version of the ISA bus which operates at the speed of the computer's CPU. See *PCI*, *EISA*, and *ISA*.
- VGA** - An acronym for Video Graphics Array. A standard for monitor displays.
- VR** - Pentium CPU voltage ranging from 3.300 - 3.465 Volts.
- VRE** - Pentium CPU voltage ranging from 3.400 - 3.600 Volts.
- Warm Boot** - Restarting the system by simultaneously pressing the <Ctrl>, <Alt>, and <Delete> keys.
- Write-Back Cache** - Upon a cache hit, the cache is updated and the main memory is not affected. Upon a cache miss, only the main memory is updated.



Write-Through Cache - Upon a cache hit, the cache and the main memory are updated.  
Upon a cache miss, only the main memory is updated.

## Limited Warranty

Except as described below, Micronics warrants the products to be free from defects in material and workmanship in normal use for a period of one (1) year from date of purchase. Should any product fail to perform according to this warranty at any time during the warranty period, except as provided below, Micronics or its authorized service centers will, at Micronics' option, repair or replace the product at no additional charge.

The warranty does not cover loss or damage which occurs in shipment or which is due to: (1) improper installation or maintenance, misuse, neglect or any cause other than ordinary commercial application, including without limitation, accidents or acts of God; (2) adjustment, repair, or modification by other than a Micronics authorized service center; (3) improper environment, excessive or inadequate heating or air conditioning, or electrical power failures, surges or other irregularities; (4) any statement about the product other than those set forth in this warranty; or (5) nonconformity to models or samples shown to the purchaser. Any models or samples were for the sole purpose of suggesting the character of the product and are not intended to form the basis of the bargain.

A receipt or copy of the invoice with the date of purchase from a Micronics reseller is required before any warranty service can be rendered. Service can be obtained by calling Micronics for a Return Merchandise Authorization (RMA) Number.

The RMA Number should be prominently displayed on the outside of the shipping carton of the returned product. Returned product should be shipped prepaid or hand carried to Micronics. The purchaser assumes risk of loss or damage in transit, and unless otherwise agreed to in writing by Micronics, will pay inbound shipping charges.

The exclusive remedy of the purchaser under this warranty above will be repair or replace at Micronics' option, but if for any reason that remedy should fail of its essential purpose, the exclusive remedy of the purchaser shall then be actual damages up to amounts paid for the defective product by the purchaser. This limited warranty shall be deemed to "fail of its essential purpose" if, after repeated efforts, Micronics is unable to make the product operate as warranted. Micronics' liability for damages to the purchaser for any cause whatsoever; regardless of the form of action and whether in contract or in tort, shall be limited to the purchase price in effect when the cause of action arose for the product that is the basis of the claim.

Micronics will not be liable for any lost profits or any indirect, special incidental or consequential damages in connection with the product, even if Micronics has been advised of the possibility of such damages.

Micronics makes no warranties or representations as to performance of products or as to service to distributor or to any person, except as set forth in Micronics; limited warranty accompanying delivery of product.

Micronics disclaims all other warranties whether oral, written, expressed, or implied, including without limitation, the warranties of design, merchantability, or fitness for a particular purpose, if applicable, or arising from a course of dealing, usage or trade practice.

## **Non-Warranty Service**

After the one year warranty service is no longer in effect, repair service is still available for Micronics products. For more information, contact Micronics' RMA department at (510) 683-0428 or (510) 683-0389. The RMA department is open between 8:30 A.M. and 5 P.M. Pacific Standard Time.