

Rack-mountable Silicon Graphics® Tezro™  
Visual Workstation Hardware User's Guide

007-4643-001

---

## CONTRIBUTORS

Written by Matt Hoy, Francisco Razo, and Mark Schwenden

Illustrated by Dan Young

Production by Glen Traefald

Engineering contributions by Charles Alexander, David Diederichs, Jeff Milo, Dave North, Jim Passint, Paul Pedersen, Keith Rich, Bruce Shifrin, Gary Spilde, Brian Stickney, and Michael Wright

---

## COPYRIGHT

© 2003, Silicon Graphics, Inc. All rights reserved; provided portions may be copyright in third parties, as indicated elsewhere herein. No permission is granted to copy, distribute, or create derivative works from the contents of this electronic documentation in any manner, in whole or in part, without the prior written permission of Silicon Graphics, Inc.

---

## LIMITED RIGHTS LEGEND

The electronic (software) version of this document was developed at private expense; if acquired under an agreement with the USA government or any contractor thereto, it is acquired as "commercial computer software" subject to the provisions of its applicable license agreement, as specified in (a) 48 CFR 12.212 of the FAR; or, if acquired for Department of Defense units, (b) 48 CFR 227-7202 of the DoD FAR Supplement; or sections succeeding thereto. Contractor/manufacturer is Silicon Graphics, Inc., 1600 Amphitheatre Pkwy 2E, Mountain View, CA 94043-1351.

---

## TRADEMARKS AND ATTRIBUTIONS

Silicon Graphics, SGI, the SGI logo, IRIX, O2, Octane, Onyx2, and Origin are registered trademarks, and NUMAlink, O2+, Octane2, Stereo View, Tezro, and VPro are trademarks of Silicon Graphics, Inc., in the United States and/or other countries worldwide. Supportfolio is a trademark and service mark of Silicon Graphics, Inc. in the United States and/or other countries worldwide.

MIPS is a trademark of MIPS Technologies, Inc., used under license by Silicon Graphics, Inc. Primus is a trademark of Primus Knowledge Solutions Inc. Spaceball is a trademark of the Logitech group.

For regulatory and compliance information, see Appendix C, "Safety and Regulatory Information."

Cover design By Sarah Bolles, Sarah Bolles Design, and Dany Galgani, SGI Technical Publications.

---

## Record of Revision

<b>Version</b>	<b>Description</b>
001	May 2003 Original Publication



---

# Contents

<b>Figures</b>	ix
<b>Tables</b>	xiii
<b>About This Guide</b>	xv
Chapter Descriptions	xv
Related Publications	xvi
Conventions	xvii
Product Support	xviii
Reader Comments	xviii
<b>1. Installation and Operation Procedures</b>	1
Setting Up the Workstation	1
Checking Your Shipment	2
Lifting the Workstation	2
Getting Acquainted	2
Installing the Workstation	4
Cabling the Workstation	5
Using the Workstation	9
Powering On the Workstation	10
Using the IRIX Interactive Desktop	11
Using the System Manager	12
Powering Off the Workstation	13
Powering Off with the Power Button	13
Powering Off from the Toolchest	15
Restarting from the Toolchest	17
<b>2. System Overview</b>	19
System Features	19

System Components . . . . .	. 20
External Components . . . . .	. 20
Front Panel Components. . . . .	. 21
Rear Panel Components . . . . .	. 22
Internal Components . . . . .	. 25
Processors . . . . .	. 26
Memory DIMMs . . . . .	. 26
IO9 Board . . . . .	. 28
Internal Hard Disk Drives . . . . .	. 28
DVD-ROM Drive . . . . .	. 29
VPro™ Graphics Board . . . . .	. 30
PCI Busses . . . . .	. 30
Power Supply . . . . .	. 31
Optional Components, Peripherals, and Upgrades. . . . .	. 32
PCI Boards . . . . .	. 32
Memory Upgrades. . . . .	. 33
Graphics Options . . . . .	. 33
Storage Options . . . . .	. 33
Displays. . . . .	. 34
Peripherals . . . . .	. 34
<b>3. Installing and Removing Customer-replaceable Units . . . . .</b>	<b>. 35</b>
Safety Instructions . . . . .	. 35
Accessing Internal System Components. . . . .	. 38
PCI and PCI-X Cards . . . . .	. 39
Installing a Card . . . . .	. 40
Removing a Card . . . . .	. 45
Disk Drives . . . . .	. 51
Installing a Disk Drive . . . . .	. 52
Removing a Disk Drive . . . . .	. 54
Memory . . . . .	. 56
Installing a DIMM . . . . .	. 58
Removing a DIMM . . . . .	. 62
L1 Controller Display . . . . .	. 65

Power Supplies . . . . .	70
Reading the Power Supply LEDs . . . . .	71
Replacing the Power Supply. . . . .	71
<b>4. Troubleshooting . . . . .</b>	<b>75</b>
Troubleshooting Chart . . . . .	76
L1 Controller Error Messages . . . . .	77
SGI Electronic Support . . . . .	79
<b>A. Technical Specifications and Pinouts . . . . .</b>	<b>83</b>
Physical and Environmental Specifications. . . . .	84
Power Supply Specifications . . . . .	85
I/O Connector Specifications . . . . .	86
Ethernet 10/100/1000BaseT Port . . . . .	87
Keyboard and Mouse Connectors . . . . .	88
Serial Ports. . . . .	90
External SCSI Port Connector . . . . .	91
Stereo Jack Connector Conductor . . . . .	93
USB Type A Connector . . . . .	94
VPro™ Graphics Board I/O Port Specifications . . . . .	95
DVI-I Video Port . . . . .	95
Stereo View Port . . . . .	98
Genlock Port . . . . .	99
Swap Ready Port . . . . .	100
Rack Specifications . . . . .	101
<b>B. Rackmounting Rail Installation Instructions . . . . .</b>	<b>103</b>
Space Requirements . . . . .	103
Rackmounting Hardware. . . . .	104
Preparing the Slide Rail Assemblies. . . . .	105
Preparing the Module. . . . .	108
Determining Where to Attach the Slide Rail in the Rack . . . . .	109
Attaching the Slide Rail to the Rack . . . . .	110
Installing Clip Nuts in Rack Rails . . . . .	113

---

Installing Modules in the Rack . . . . .	114
Adjusting the Position of the Rackmounted Module . . . . .	116
Removing a Module from a Rack. . . . .	117
<b>C. Safety and Regulatory Information . . . . .</b>	<b>121</b>
General Safety Information . . . . .	121
Manufacturer’s Regulatory Declarations . . . . .	123
System Numbers . . . . .	123
Manufacturer’s Declaration of Conformity . . . . .	124
CE Notice . . . . .	124
Electromagnetic Emissions Notices . . . . .	124
Industry Canada Notice (Canada Only) . . . . .	125
VCCI Notice (Japan Only) . . . . .	125
Chinese Class A Regulatory Notice . . . . .	126
Korean Class A Regulatory Notice . . . . .	126
Shielded Cables. . . . .	126
Electrostatic Discharge. . . . .	127
Lithium Battery Statement . . . . .	127
Laser Compliance Statements. . . . .	128



---

# Figures

<b>Figure 1-1</b>	Front View of the Workstation . . . . .	3
<b>Figure 1-2</b>	Rear View of the Workstation. . . . .	3
<b>Figure 1-3</b>	Connecting the Keyboard and Mouse Cables . . . . .	5
<b>Figure 1-4</b>	Connecting the Ethernet Cable . . . . .	6
<b>Figure 1-5</b>	Connecting the Monitor Cable . . . . .	7
<b>Figure 1-6</b>	Connecting the Power Cable . . . . .	8
<b>Figure 1-7</b>	Cabling a Dual-enclosure Workstation . . . . .	9
<b>Figure 1-8</b>	Powering On the Workstation . . . . .	10
<b>Figure 1-9</b>	Login Screen . . . . .	11
<b>Figure 1-10</b>	Peripheral Icons. . . . .	12
<b>Figure 1-11</b>	Toolchest Menu. . . . .	12
<b>Figure 1-12</b>	Console Window . . . . .	13
<b>Figure 1-13</b>	System Shutdown Notifier . . . . .	14
<b>Figure 1-14</b>	Power Button and Reset Button . . . . .	14
<b>Figure 1-15</b>	Shutdown Caution Message . . . . .	15
<b>Figure 1-16</b>	Restart System Option . . . . .	16
<b>Figure 1-17</b>	System Shutdown Notifier . . . . .	16
<b>Figure 1-18</b>	Restart Notifier . . . . .	17
<b>Figure 1-19</b>	System Shutdown Notifier . . . . .	18
<b>Figure 1-20</b>	Power Off/Restart Notifier . . . . .	18
<b>Figure 1-21</b>	Restart Notifier . . . . .	18
<b>Figure 2-1</b>	Single- and Dual-enclosure Rack-mountable Workstations . . . . .	20
<b>Figure 2-2</b>	Front Panel Components . . . . .	21
<b>Figure 2-3</b>	Rear Panel Components . . . . .	24
<b>Figure 2-4</b>	System Architecture . . . . .	25
<b>Figure 2-5</b>	DIMM Sockets and Pairs . . . . .	27
<b>Figure 2-6</b>	Internal Hard Disk Drives and DVD-ROM Drive . . . . .	29

<b>Figure 2-7</b>	Power Supply Location . . . . .	. 31
<b>Figure 3-1</b>	Removing the Enclosure Top Cover Screws . . . . .	. 38
<b>Figure 3-2</b>	Closing and Replacing the Enclosure's Top Cover . . . . .	. 39
<b>Figure 3-3</b>	PCI and PCI-X Card Slots Located in the Rear Panel . . . . .	. 40
<b>Figure 3-4</b>	Removing the Lower PCI/PCI-X Support Bracket . . . . .	. 41
<b>Figure 3-5</b>	Removing a Blanking Plate. . . . .	. 42
<b>Figure 3-6</b>	Installing the Card and Retaining Screw . . . . .	. 43
<b>Figure 3-7</b>	Replacing the Lower PCI/PCI-X Support Bracket . . . . .	. 44
<b>Figure 3-8</b>	Removing the Lower PCI/PCI-X Support Bracket . . . . .	. 46
<b>Figure 3-9</b>	Removing the Retaining Screw and Extracting the Card . . . . .	. 47
<b>Figure 3-10</b>	Placing a Blanking Plate . . . . .	. 48
<b>Figure 3-11</b>	Replacing the Lower PCI/PCI-X Support Bracket . . . . .	. 49
<b>Figure 3-12</b>	Disk Drive Location. . . . .	. 51
<b>Figure 3-13</b>	Installing a Disk Drive . . . . .	. 53
<b>Figure 3-14</b>	Removing a Disk Drive. . . . .	. 55
<b>Figure 3-15</b>	Layout of DIMM Slots and Local Memory Banks . . . . .	. 57
<b>Figure 3-16</b>	Opening the Enclosure Cover to Install DIMMs. . . . .	. 59
<b>Figure 3-17</b>	Removing the Plastic Air Baffle . . . . .	. 60
<b>Figure 3-18</b>	Inserting a DIMM . . . . .	. 61
<b>Figure 3-19</b>	Opening the Enclosure . . . . .	. 62
<b>Figure 3-20</b>	Removing the Plastic Air Baffle . . . . .	. 63
<b>Figure 3-21</b>	Removing a DIMM . . . . .	. 64
<b>Figure 3-22</b>	L1 Controller Display on the Front Panel. . . . .	. 65
<b>Figure 3-23</b>	Opening the Enclosure to Access the L1 Controller Display . . . . .	. 66
<b>Figure 3-24</b>	Removing the L1 Controller Display Panel . . . . .	. 67
<b>Figure 3-25</b>	Installing an L1 Controller Display Panel . . . . .	. 68
<b>Figure 3-26</b>	Power Supply Location. . . . .	. 70
<b>Figure 3-27</b>	Removing the Power Supply . . . . .	. 73
<b>Figure 3-28</b>	Installing the Power Supply . . . . .	. 74
<b>Figure 4-1</b>	Full Support Sequence . . . . .	. 79
<b>Figure A-1</b>	Rear Panel Connectors . . . . .	. 87
<b>Figure A-2</b>	Ethernet 10/100/1000BaseT Port Pinout . . . . .	. 87
<b>Figure A-3</b>	PS/2 Keyboard and Mouse Port Pinout . . . . .	. 88

<b>Figure A-4</b>	Serial Port Pinouts and Locations. . . . .	90
<b>Figure A-5</b>	External SCSI Port Pin Number Locations . . . . .	91
<b>Figure A-6</b>	Stereo Jack Connector Conductors . . . . .	93
<b>Figure A-7</b>	USB Type A Connector Pin Number Locations. . . . .	94
<b>Figure A-8</b>	DVI-I Port Pinout and Location . . . . .	95
<b>Figure A-9</b>	Stereo View Port Pinout . . . . .	98
<b>Figure A-10</b>	Genlock Port Pinout . . . . .	99
<b>Figure A-11</b>	Swap Ready Port Pinout . . . . .	.100
<b>Figure B-1</b>	Separating the Chassis Rail from the Slide Rail . . . . .	.105
<b>Figure B-2</b>	Attaching the Rear Mounting Bracket to the Slide Rail . . . . .	.107
<b>Figure B-3</b>	Attaching Chassis Rails to the Module Chassis . . . . .	.108
<b>Figure B-4</b>	Mounting Hole Pattern of Rack Vertical Rails . . . . .	.109
<b>Figure B-5</b>	Placing the Bar Nuts on the Rack Rails . . . . .	.111
<b>Figure B-6</b>	Attaching the Slide Rail to the Rack . . . . .	.112
<b>Figure B-7</b>	Installing Clip Nuts in Rack Rails . . . . .	.113
<b>Figure B-8</b>	Pressing the Safety Latches . . . . .	.115
<b>Figure B-9</b>	Securing the Module to the Rack . . . . .	.116
<b>Figure B-10</b>	Releasing the Safety Latches . . . . .	.118
<b>Figure B-11</b>	Releasing the Slide Latches . . . . .	.119



---

# Tables

<b>Table 3-1</b>	DIMMs and Bank Pairs . . . . .	56
<b>Table 3-2</b>	LED Status and Power Supply Condition . . . . .	71
<b>Table 4-1</b>	Troubleshooting Chart . . . . .	76
<b>Table 4-2</b>	L1 Controller Messages . . . . .	77
<b>Table A-1</b>	Physical and Environmental Specifications . . . . .	84
<b>Table A-2</b>	Power Supply Specification . . . . .	85
<b>Table A-3</b>	Workstation Connectors . . . . .	86
<b>Table A-4</b>	Ethernet Connector Pin Assignments . . . . .	88
<b>Table A-5</b>	Keyboard and Mouse Port Pinout . . . . .	89
<b>Table A-6</b>	Serial Port Pinout . . . . .	91
<b>Table A-7</b>	SCSI VHDCI Pin Assignments . . . . .	91
<b>Table A-8</b>	Stereo Jack Connector Conductor Assignments . . . . .	93
<b>Table A-9</b>	USB Type A Connector Pin Assignments . . . . .	94
<b>Table A-10</b>	DVI-I Video Port Pinout . . . . .	96
<b>Table A-11</b>	Supported VPro Graphics Board Scan Rates . . . . .	97
<b>Table A-12</b>	Stereo View Pinout Assignments . . . . .	98
<b>Table A-13</b>	Genlock Pinout Assignments . . . . .	99
<b>Table A-14</b>	Swap Ready Pinout Assignments . . . . .	100
<b>Table A-15</b>	Short Rack Specifications . . . . .	101
<b>Table A-16</b>	Tall-rack Specifications . . . . .	101
<b>Table B-1</b>	Space Requirements . . . . .	103
<b>Table B-2</b>	Rackmounting Hardware . . . . .	104



---

## About This Guide

Welcome to the user's guide for the rack-mountable Silicon Graphics® Tezro™ visual workstation. Your new workstation offers VPro™ graphics and a high-bandwidth architecture in a convenient rack-mountable form-factor.

This guide shows you how to set up, use, and troubleshoot your system. This guide is provided for all end-users and SGI technical support staff. Most of the hardware tasks are relatively simple and require no previous computer knowledge. A few tasks are more difficult; they are easier to perform if you have some computer hardware experience.

### Chapter Descriptions

The following topics are covered in this guide:

- Chapter 1, “Installation and Operation Procedures” provides instructions for unpacking and setting up your new workstation. It also explains how to power the workstation on, log in, access programs, and power off the workstation.
- Chapter 2, “System Overview” describes the parts of the workstation and gives an overview of how they work together. It also provides configuration information and describes optional components.
- Chapter 3, “Installing and Removing Customer-replaceable Units” provides instructions for installing and removing parts of the system. If the part you wish to add or replace does not appear in this chapter, contact your SGI service representative.
- Chapter 4, “Troubleshooting” explains how to find problems with your system and resolve them. It also includes information about available support options.
- Appendix A, “Technical Specifications and Pinouts,” provides specifications for the size, weight, and power consumption of the system. It also lists environmental specifications and connector pinouts.
- Appendix B, “Rackmounting Rail Installation Instructions,” provides instructions for mounting your workstation in a standard 19-in. rack.

- Appendix C, “Safety and Regulatory Information,” provides a list of safety instructions to follow when installing, operating, or servicing the system and lists all regulatory information related to use of the workstation in the United States and other countries.

## Related Publications

For complete information on installing software, see the online *Personal System Administration Guide*. It is located on your desktop in **Toolchest > Help > Online Books**. For more advanced information, see the online *IRIX Admin: Software Installation & Licensing Guide*. For system administration information, see the **SGI\_Admin** section of the online bookshelf.

It is always a good idea to back up your system. For instructions on backing up your system, see the online *Personal System Administration Guide*.

You can obtain SGI documentation, release notes, or man pages in the following ways:

- See the SGI Technical Publications Library at <http://docs.sgi.com>. Various formats are available. This library contains the most recent and most comprehensive set of online books, release notes, man pages, and other information.
- If it is installed on your SGI system, you can use InfoSearch, an online tool that provides a more limited set of online books, release notes, and man pages. With an IRIX system, select **Help** from the Toolchest, and then select **InfoSearch**. Or you can type **infosearch** on a command line.
- You can also view release notes by typing either **grelnotes** or **relnotes** on a command line.
- You can also view man pages by typing **man <title>** on a command line.

SGI systems include a set of IRIX man pages, formatted in the standard UNIX “man page” style. Important system configuration files and commands are documented on man pages. These are found online on the internal system disk (or CD-ROM) and are displayed using the man command. For example, to display the man page for the `Add_disk` command, type the following on a command line:

```
man Add_disk
```

References in the documentation to these pages include the name of the command and the section number in which the command is found. For example, “Add\_disk(1)” refers



to the `Add_disk` command and indicates that it is found in section 1 of the IRIX reference.

For additional information about displaying man pages using the `man` command, see `man(1)`.

In addition, the `apropos` command locates man pages based on keywords. For example, to display a list of man pages that describe disks, type the following on a command line:

```
apropos disk
```

For information about setting up and using `apropos`, see `apropos(1)` and `makewhatis(1M)`.

## Conventions

The following conventions are used throughout this document:

Convention	Meaning
Command	This fixed-space font denotes literal items such as commands, files, routines, path names, signals, messages, and programming language structures.
<i>variable</i>	The italic typeface denotes variable entries and words or concepts being defined. Italic typeface also is used for book titles.
<b>user input</b>	This fixed-space font denotes literal items that the user enters in interactive sessions. Output is shown in nonbold, fixed-space font.
[ ]	Brackets enclose optional portions of a command or directive line.
...	Ellipses indicate that a preceding element can be repeated.
man page( <i>x</i> )	Man page section identifiers appear in parentheses after man page names.
<b>GUI element</b>	This font denotes the names of graphical user interface (GUI) elements such as windows, screens, dialog boxes, menus, toolbars, icons, buttons, boxes, fields, and lists.

## Product Support

SGI provides a comprehensive product support and maintenance program for its products, as follows:

- If you are in North America, contact the Technical Assistance Center at 1 800 800 4SGI or contact your authorized service provider.
- If you are outside North America, contact the SGI subsidiary or authorized distributor in your country.

## Reader Comments

If you have comments about the technical accuracy, content, or organization of this document, contact SGI. Be sure to include the title and document number of the manual with your comments. (Online, the document number is located in the front matter of the manual. In printed manuals, the document number is located at the bottom of each page.)

You can contact SGI in any of the following ways:

- Send e-mail to the following address:  
techpubs@sgi.com
- Use the Feedback option on the Technical Publications Library website:  
<http://docs.sgi.com>
- Contact your customer service representative and ask that an incident be filed in the SGI incident tracking system.
- Send mail to the following address:  
Technical Publications  
SGI  
1600 Amphitheatre Pkwy., M/S 535  
Mountain View, California 94043-1351
- Send a fax to the attention of “Technical Publications” at +1 650 932 0801.

SGI values your comments and will respond to them promptly.

# Installation and Operation Procedures

This chapter shows you how to set up and use your rack-mountable Silicon Graphics® Tezro™ visual workstation in the following sections:

- “Setting Up the Workstation” on page 1
- “Using the Workstation” on page 9

## Setting Up the Workstation

This section covers the following topics:

- “Checking Your Shipment” on page 2
- “Lifting the Workstation” on page 2
- “Getting Acquainted” on page 2
- “Installing the Workstation” on page 4
- “Cabling the Workstation” on page 5

## Checking Your Shipment

The following basic components are included in the shipment:

- Workstation enclosure(s)
- Keyboard and mouse
- Monitor and monitor cable
- Operating system CDs
- Power cables
- Anti-static wrist-strap

If you ordered additional optional components, those will also be shipped with your system. If any of the components you ordered are damaged or missing, contact your support provider.

## Lifting the Workstation

The workstation enclosure weighs approximately 18 kg (40 lb). SGI highly recommends that two people lift the unit when it must be moved. Lift the unit by placing your hands under the bottom edges of the enclosure.

## Getting Acquainted

To become familiar with your workstation, see the following figures:

- Figure 1-1, which shows a front views of the single- and dual-enclosure workstation.
- Figure 1-2, which shows rear views of the single- and dual-enclosure workstation.

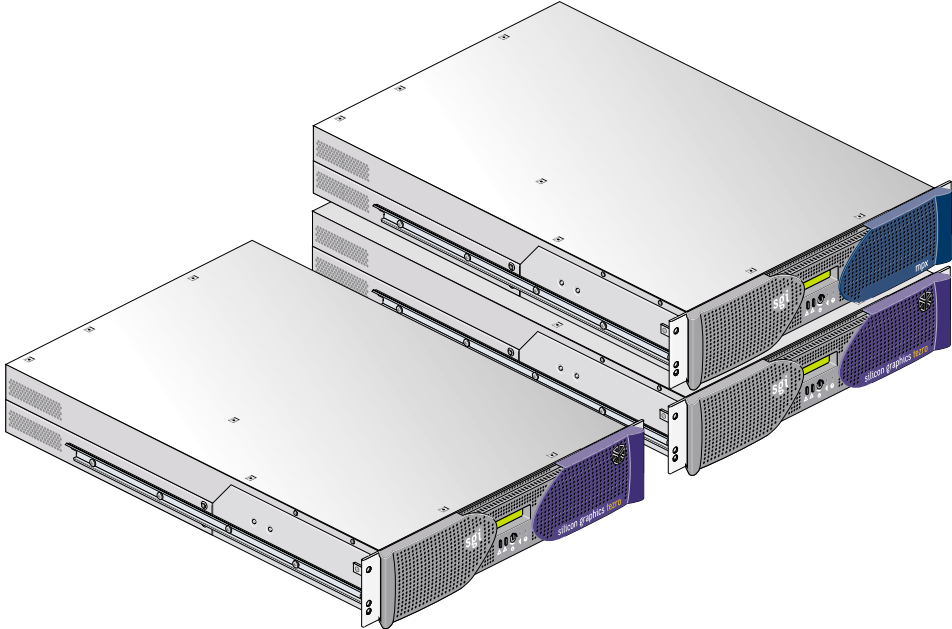


Figure 1-1 Front View of the Workstation

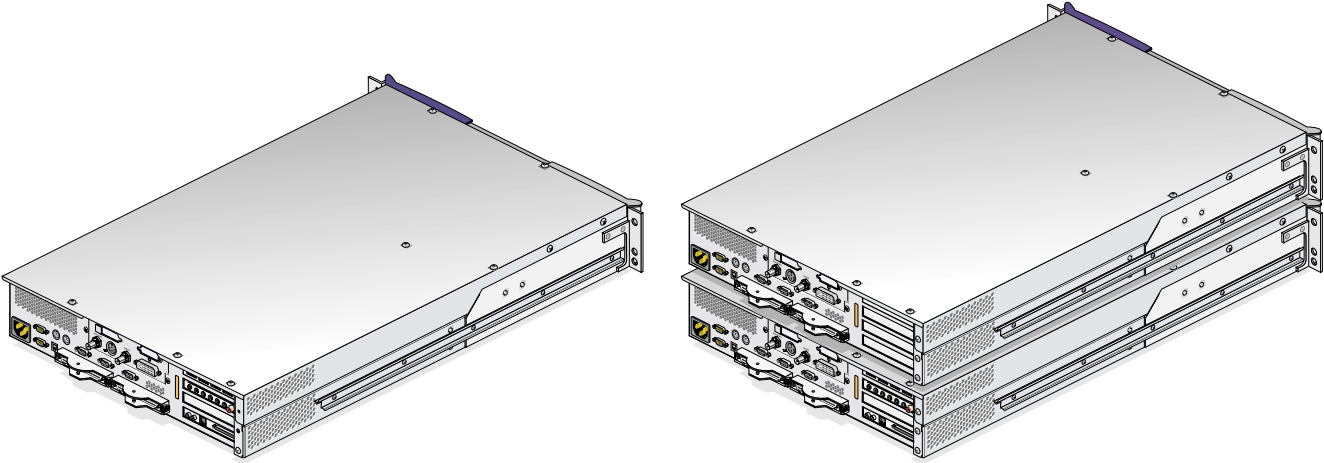


Figure 1-2 Rear View of the Workstation

After you have set up your workstation and logged in, see the following resources for more information:

- From the **Toolchest**, select **System > System Manager** for information on the workstation's hardware and software.
- From the **Toolchest**, select **System > System Manager > About This System** to learn about your system's serial number, IP address, operating system, and more.

## Installing the Workstation

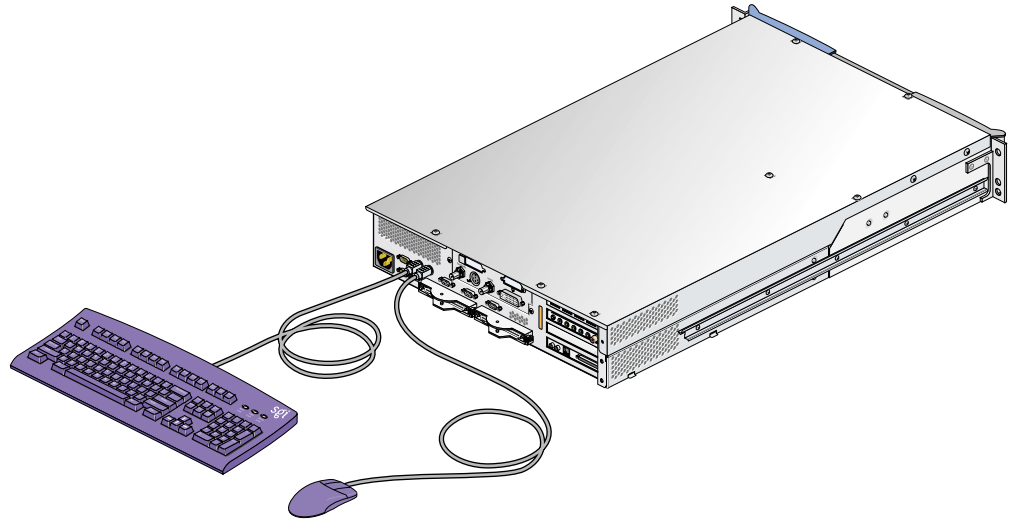
The workstation can be mounted in an optional SGI rack, a standard 19-in. rack, or placed on a table top. If you do not wish to mount your workstation in a rack, place it on a sturdy surface with adequate clearances for cooling. Then proceed to the next section.

For instructions on installing your workstation in a rack, see Appendix B. After you have installed the workstation enclosure(s) in the rack, proceed to the next section.

## Cabling the Workstation

To cable the workstation, follow these steps:

1. Connect the keyboard and mouse cables, as shown in Figure 1-3.



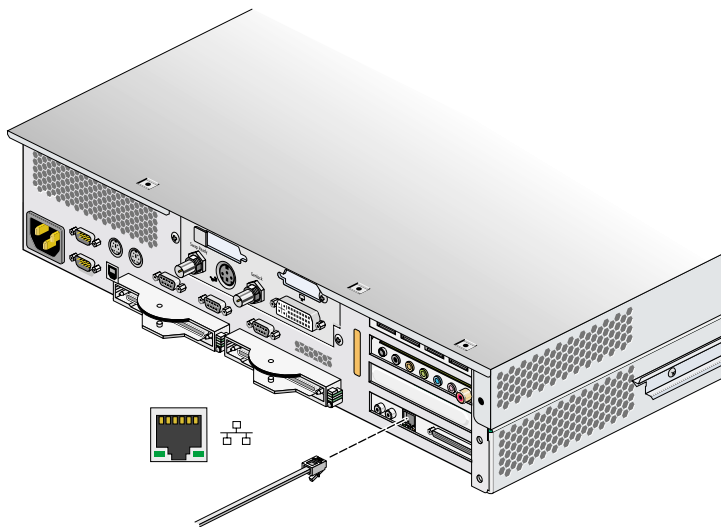
**Figure 1-3** Connecting the Keyboard and Mouse Cables

---

**Note:** The workstation in Figure 1-3 is shown with the optional USB and audio boards. Your workstation may or may not be equipped with these boards.

---

2. Connect the Ethernet cable to the Ethernet port on the IO9 card, as shown in Figure 1-4.



**Figure 1-4** Connecting the Ethernet Cable

---

**Note:** The workstation in Figure 1-4 is shown with the optional USB and audio boards. Your workstation may or may not be equipped with these boards.

---

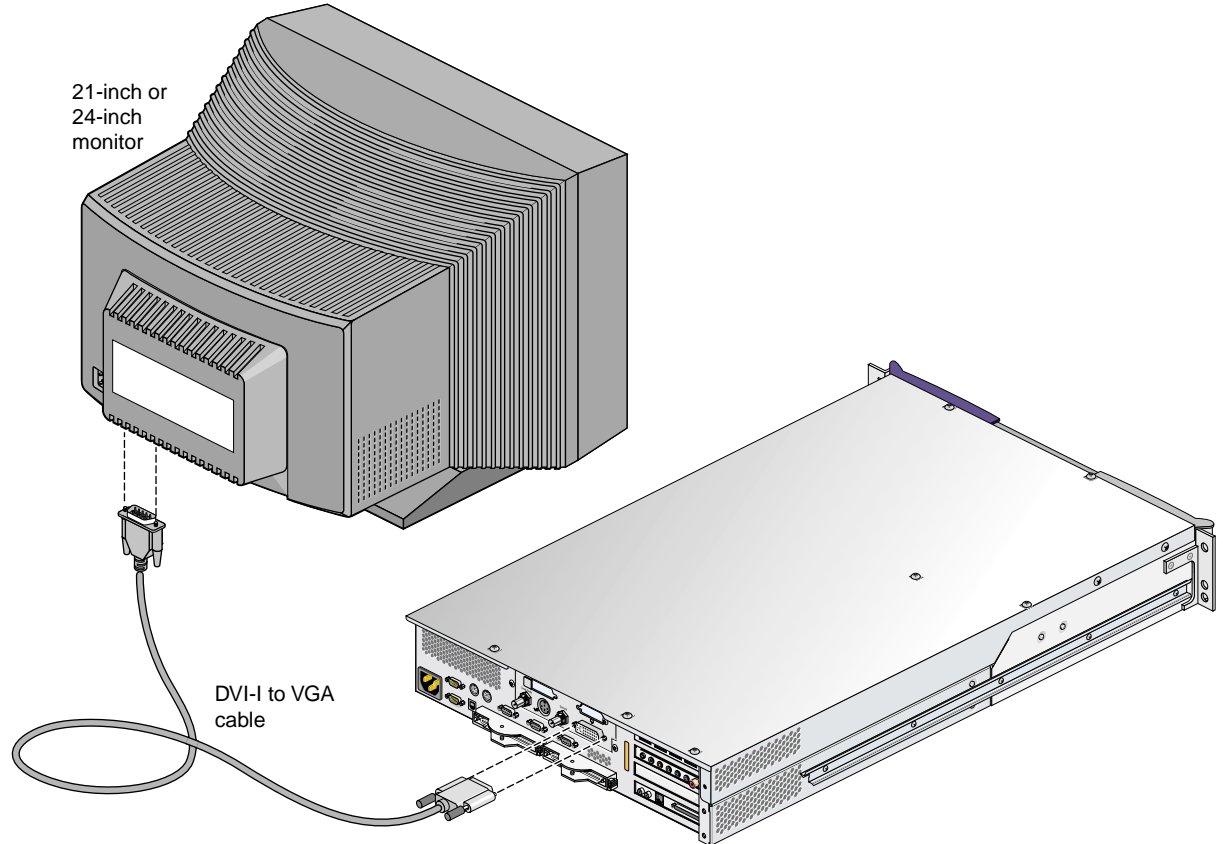
3. Connect the monitor cable, as follows (see Figure 1-5):
  - Connect the monitor-to-graphics cable to the monitor.
  - Connect the monitor-to-graphics cable to the DVI-I video connector on the back of your workstation.

---

**Note:** The workstation can be connected to a variety of monitors. Your monitor and monitor cable may differ from those shown. If your monitor has multiple inputs, ensure that the source switch is set to the correct input port.

---





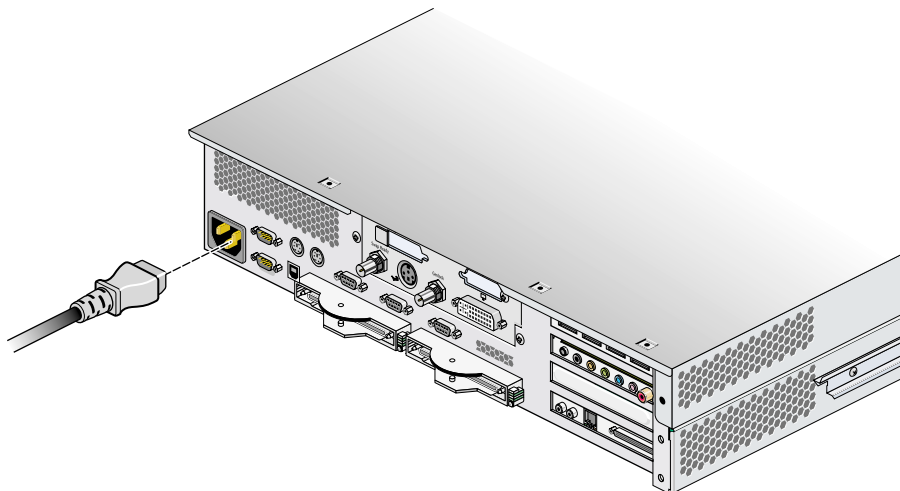
**Figure 1-5** Connecting the Monitor Cable

---

**Note:** The workstation in Figure 1-5 is shown with the optional USB and audio boards. Your workstation may or may not be equipped with these boards.

---

4. Connect the power cables to your workstation and monitor and then plug them into approved electrical outlets. See Figure 1-6.



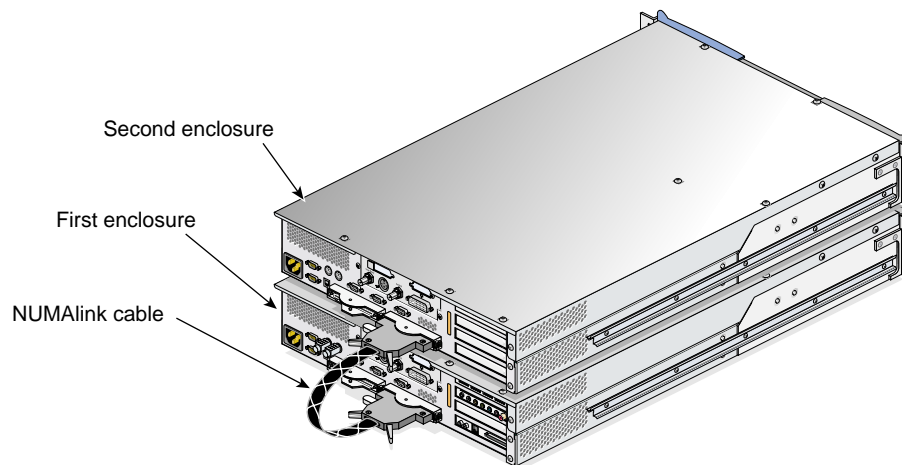
**Figure 1-6** Connecting the Power Cable

---

**Note:** The workstation in Figure 1-6 is shown with the optional USB and audio boards. Your workstation may or may not be equipped with these boards.

---

5. Connect any remaining peripheral cables as needed. For cabling instructions, see the documentation that came with your peripherals.
6. If you are installing a dual-enclosure workstation, proceed to the next step. If you are installing a single-enclosure workstation, proceed to the next section.
7. Connect the NUMAlink cable between the first and second enclosures as follows (see Figure 1-7):
  - a. Ensure that the locking tabs on both ends of the cable are in the open position (swung away from the connector base).
  - b. Insert the cable into the NUMAlink port on the rear of the first enclosure. Secure the cable in the connector by closing the locking tab.
  - c. Insert the other end of the cable into the NUMAlink port on the rear of the second enclosure. Secure the cable in the connector by closing the locking tab.



**Figure 1-7** Cabling a Dual-enclosure Workstation

8. Connect a power cable to the second enclosure (see Figure 1-6).
9. If present, connect cables to the option boards installed in second enclosure.

You have finished setting up your workstation. Proceed to the next section.

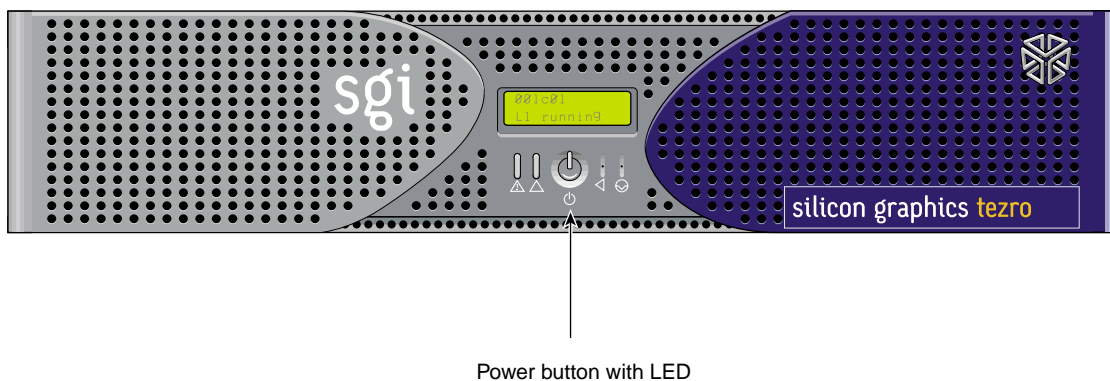
## Using the Workstation

This section provides information about using your workstation in the following sections:

- “Powering On the Workstation” on page 10
- “Using the IRIX Interactive Desktop” on page 11
- “Using the System Manager” on page 12
- “Powering Off the Workstation” on page 13

## Powering On the Workstation

Press the power button on workstation as shown in Figure 1-8. If your workstation is equipped with an optional second enclosure, press the power button on the second enclosure too. Then power on your monitor.



**Figure 1-8** Powering On the Workstation

A green LED flashing on the front of the workstation indicates that the system is booting. The monitor may remain blank for a few moments. If your system does not boot, see Chapter 4, "Troubleshooting."

If your system is booting for the first time, you will see a login screen similar to the example shown in Figure 1-9.



**Figure 1-9** Login Screen

If you have a login account, double-click the icon with your login name. If you do not have a login account, double-click **EZsetup** and then follow the instructions for creating a personal login account and setting up the networking software. Then you can begin using the IRIX interactive desktop to create a personal work area and communicate with other users on your network.

## Using the IRIX Interactive Desktop

After you have logged in, you are ready to use the IRIX interactive desktop. By default, several icons appear on your desktop: a folder icon representing your home directory, a dumpster icon, and icons for any peripherals you installed, examples of which are shown in Figure 1-10.

The peripheral icons show the current state of the respective devices. For example, if you insert a music CD into the optional DVD-ROM drive, the icon changes. When you double-click the icon, it opens CD Player, a utility that allows you to play music from a compact disc.



**Figure 1-10** Peripheral Icons

The Toolchest, located at the top left corner of your screen, provides access to system functions, applications, hardware and software information, and documentation, as shown in Figure 1-11.

---

**Note:** For a complete description of the Toolchest, select **Help > InfoSearch** from the Toolchest, and type **Desktop Users Guide**.

---



**Figure 1-11** Toolchest Menu

## Using the System Manager

From the Toolchest, select **System > System Manager** to display the System Manager, which shows your workstation's hardware and software information.

From the Toolchest, select **Help** to display the library of online documentation. If your workstation is turned off and you cannot access online documentation, this printed guide contains all the information you need. You can also access this guide and most manuals, man pages, and release notes in the SGI Technical Publications Library at <http://docs.sgi.com>, and by using InfoSearch.

From the Toolchest, select **Help > InfoSearch** and type the name of the desired book or topic to search online books, man pages, and release notes that cover end-user, developer, and system administrator information.

The small box next to the Toolchest is the **Console** window, as shown in Figure 1-12. It appears as a small box because it is minimized. You can open it to its full size by clicking it. Many system status and error messages appear in this window.



**Figure 1-12** Console Window

If you click in the **Console** window, an IRIX shell appears, where you can type IRIX commands. For information on IRIX commands, select **Help > Online Books > SGI\_End User > Desktop Users Guide > Using IRIX Commands** from the Toolchest.

## Powering Off the Workstation

You can shut down, power off, or restart your workstation in several different ways, which are explained in the following sections:

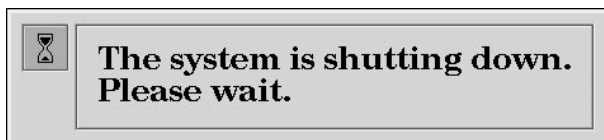
- “Powering Off with the Power Button” on page 13
- “Powering Off from the Toolchest” on page 15
- “Restarting from the Toolchest” on page 17

### Powering Off with the Power Button

To power off your workstation with the power button, follow these steps:

1. Open the door on the front of your workstation.
2. Press the power button (see Figure 1-8).

Within a few seconds, a shutdown notifier appears, as shown in Figure 1-13. Within a minute, the system powers off automatically.



**Figure 1-13** System Shutdown Notifier

3. Turn off your monitor by pressing the monitor power button.

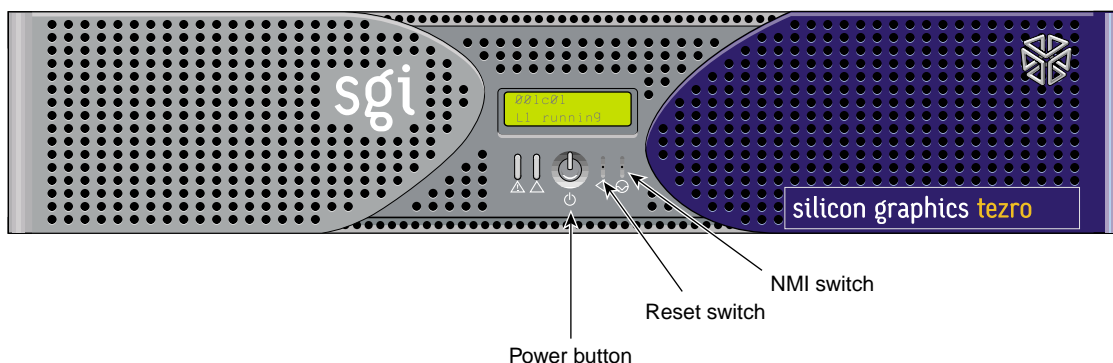
If your system does not power off and you do not see any activity for several minutes, press the power button again.

---

**Note:** If you press the power button a second time, the system should power off immediately, but this method does not perform a clean shutdown. Avoid using this method unless the system does not respond for several minutes after you first press the power button.

---

If pressing the power button a second time does not work, use a paper clip or pin to press the reset switch, shown in Figure 1-14. If the system still fails to power off, unplug the power cable from the back of your workstation and contact your service provider.



**Figure 1-14** Power Button and Reset Button



---

**Note:** The NMI switch shown in Figure 1-14 is used by SGI field engineers to diagnose problems. Do not press this button unless directed by SGI service personnel.

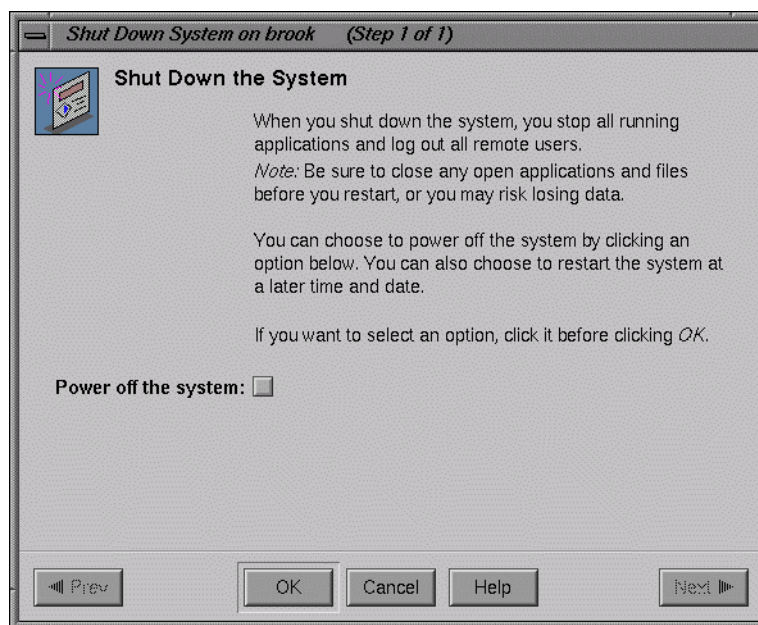
---

## Powering Off from the Toolchest

If you have root level access to the workstation, you can shut down your system from the Toolchest, as follows:

1. From the Toolchest, select **System > System Shutdown**.

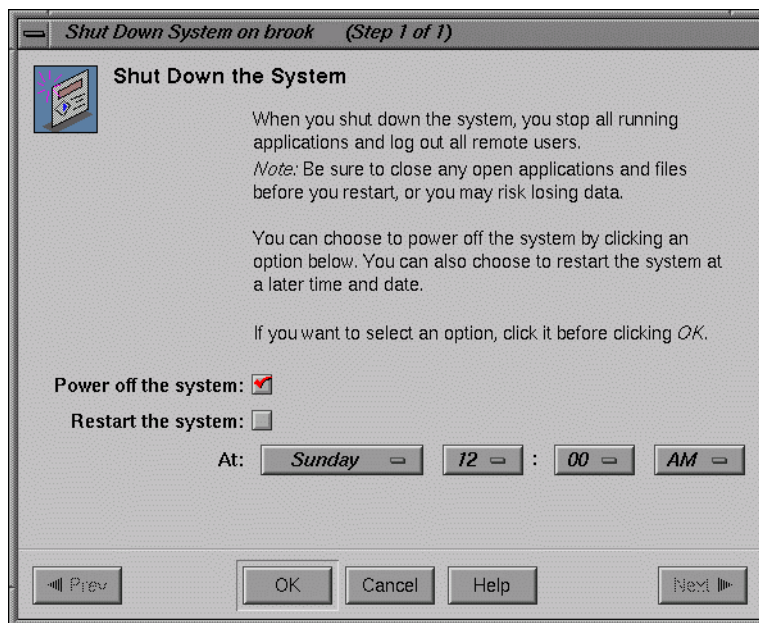
After a few seconds, a shutdown caution message appears, as shown in Figure 1-15.



**Figure 1-15** Shutdown Caution Message

2. Click the **Power Off the System** check box.

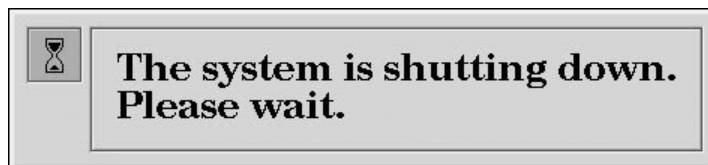
The **Restart the system** window appears. At this point, you can shut down and power off the system or configure it to restart at a designated time, as shown in Figure 1-16.



**Figure 1-16** Restart System Option

3. Click **OK** to shut down and power off the system.

The shutdown notifier appears, as shown in Figure 1-17. After a few seconds, the system powers off.



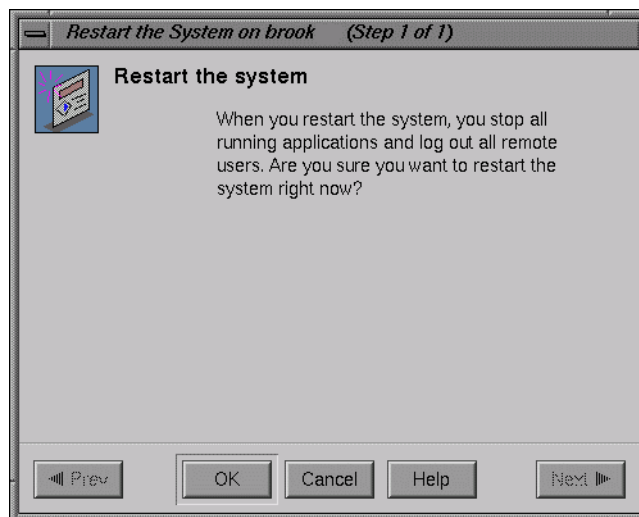
**Figure 1-17** System Shutdown Notifier

## Restarting from the Toolchest

If you have root level access to the workstation, you can restart the system from the Toolchest.

1. From the Toolchest, select **System > Restart**.

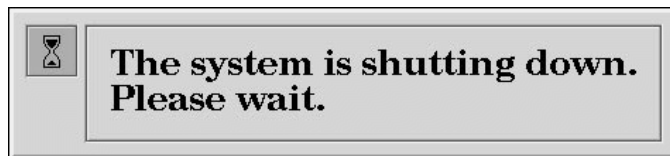
After a few seconds the restart notifier appears, as shown in Figure 1-18.



**Figure 1-18** Restart Notifier

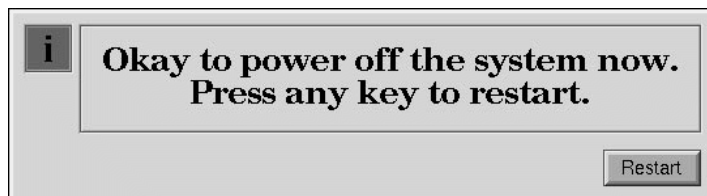
2. Click **OK** in the restart notifier.

The shutdown notifier appears, as shown in Figure 1-19.



**Figure 1-19** System Shutdown Notifier

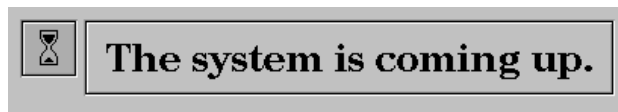
After a brief delay, the power off/restart notifier appears, as shown in Figure 1-20.



**Figure 1-20** Power Off/Restart Notifier

3. Click **Restart**.

The restart notifier informs you that the system is coming up (restarting), as shown in Figure 1-21.



**Figure 1-21** Restart Notifier

## System Overview

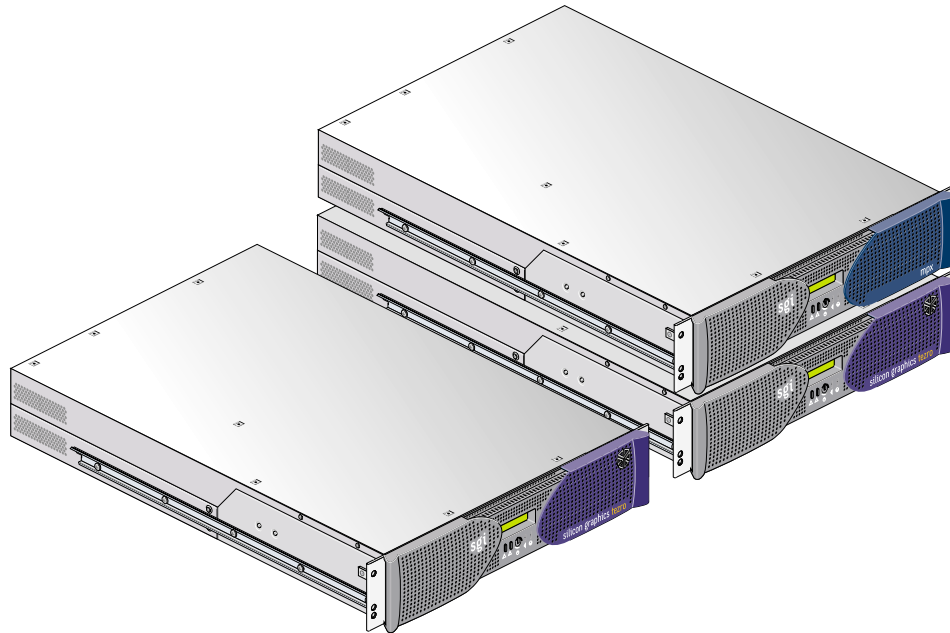
This chapter provides general information about the rack-mountable Silicon Graphics® Tezro™ visual workstation in the following sections:

- “System Features” on page 19
- “System Components” on page 20

### System Features

The rack-mountable workstation is a high-power, high-performance system. It provides VPro™ graphics, 64-bit MIPS processors, and a high-bandwidth architecture in a convenient rack-mountable form factor. Features of the system include the following:

- High-speed system architecture, available with 1, 2, or 4 processors.
- VPro graphics with dual-channel, dual-head, and digital media options.
- Scalable system memory, with capacities from 512 MB to 16 GB.
- Ultra3 SCSI internal hard-disk drives, which provide large internal storage capacities and fast access times.
- Two PCI/PCI-X compatible card buses with three available slots (four buses and seven available slots in dual-enclosure configurations).
- IO9 system I/O board for efficient control of internal and external I/O.
- Single- or dual-enclosure configuration. The optional second enclosure provides additional memory and PCI-X capacity and can also be configured with a graphics or digital media board.



**Figure 2-1** Single- and Dual-enclosure Rack-mountable Workstations

## System Components

The components of the workstation are covered in the following sections:

- “External Components” on page 20
- “Internal Components” on page 25

### External Components

This section describes the front and rear panels of the workstation and the optional second enclosure in the following sections:

- “Front Panel Components” on page 21
- “Rear Panel Components” on page 22

## Front Panel Components

The front panel of the workstation has the following components (see Figure 2-2):

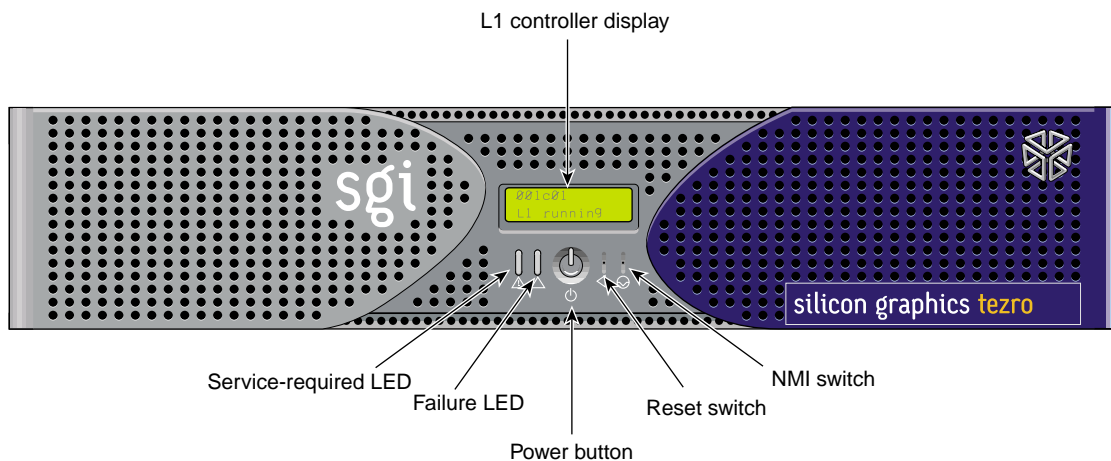
- **L1 controller display.** A liquid crystal display (LCD) displays status and error messages generated by the L1 controller.

---

**Note:** See the *SGI L1 and L2 Controller Software User's Guide* (007-3938-00x) and "L1 Controller Error Messages" on page 77 for more information on the L1 controller.

---

- **Power button with LED.** Press this button to power on the workstation. The LED illuminates green when the internal components are on.
- **Reset switch.** Activate this recessed switch with a paperclip to reset the workstation. The reset will cause a memory loss. (To perform a reset without losing memory, see the NMI switch information that follows.)
- **NMI switch.** Activate the recessed NMI (non-maskable interrupt) switch with a paperclip to reset the system without losing memory. Register data and memory are stored in a `/var/adm/crash` file.
- **Service-required LED.** This LED illuminates yellow to indicate that a component has failed or is not operating properly, but the workstation is still operating.
- **Failure LED.** This LED illuminates red to indicate that a failure has occurred and that the workstation is down.



**Figure 2-2** Front Panel Components

---

**Note:** The first and second enclosures of a dual-enclosure system have the same front panel components.

---

## Rear Panel Components

This section describes the rear panel connectors, PCI/PCI-X slots, and LEDs of the workstation enclosures (see Figure 2-3). The rear panel of the first workstation enclosure has the following components:

- **Power connector.** This connector connects the workstation enclosure(s) to an AC power outlet.
- **Console port.** This DB-9 serial port (console and diagnostic port) connects a system console to the L1 controller.
- **Serial port 1.** This DB-9 RS-232/RS-422 serial port connects a serial device such as a printer to the workstation.
- **L1 port (USB type B).** This connector is not used.
- **NUMAlink connector.** This NUMAlink connector connects the two enclosures of a dual-enclosure workstation. This connection is made with a NUMAlink cable at 1.6 GB/s in each direction.
  - **NUMAlink LED.** The NUMAlink connector has LEDs that illuminate yellow and green (located to the right of the NUMAlink connector). The yellow LED indicates that the workstation enclosures are powered on. The green LED indicates that the connection between the enclosures is functioning.
- **PCI/PCI-X slots (bus 1, slot 1; bus 1, slot 2; bus 2, slot 1; bus 2, slot 2).** These slots are labeled from bottom to top **PCI 1**, **PCI 2**, **PCI 3**, and **PCI 4**. Two of these slots are on one bus, and two slots are on another. These are 64-bit slots that can house 33-MHz and 66-MHz PCI cards or 66-MHz, 100-MHz, or 133-MHz PCI-X cards. (See SGI Supportfolio at <http://support.sgi.com> for an updated list of supported cards.) The bottom-most slot of the first enclosure always contains an IO9 PCI card.

The serial daughtercard provides the following connectors:

- **Two PS/2 ports (keyboard and mouse).** These ports connect a PS/2 keyboard and mouse to the system.
- **Serial ports 2, 3, and 4.** These three DB-9 RS-232/RS-422 serial ports connect serial devices such as printers to the system.



---

**Note:** The serial daughter-board is not available in the second enclosure of a dual-enclosure workstation.

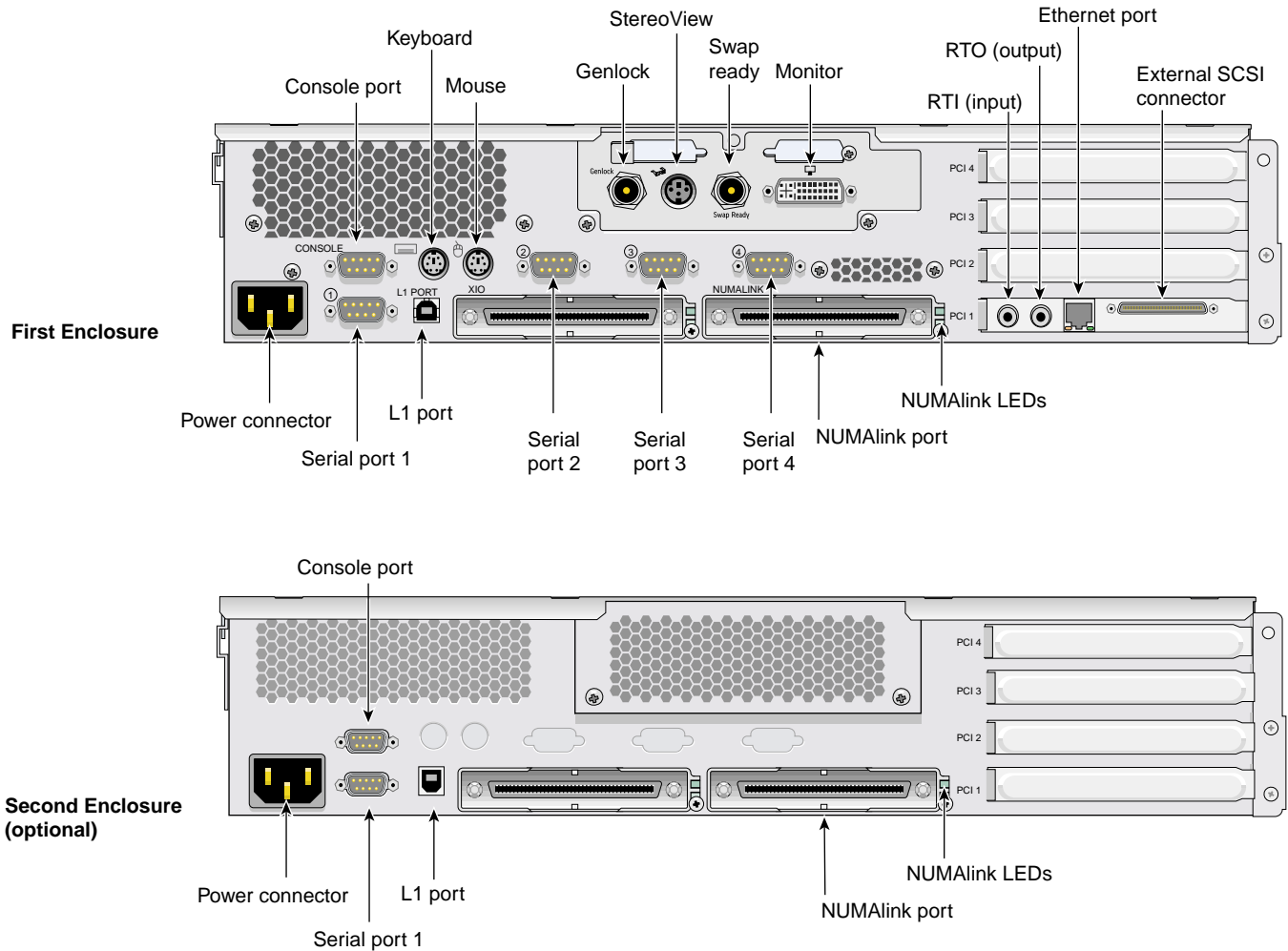
---

The factory-installed IO9 board provides the following connectors:

- **Real-time interrupt input and output.** RTO (output) enables the compute module to interrupt an external device. RTI (input) enables an external device to interrupt the workstation.
- **Ethernet port (10/100/1000 Mbits).** This auto-negotiating 10BaseT/100BaseT/1000BaseT twisted-pair Ethernet port connects the workstation to an Ethernet network.
- **External SCSI connector.** This 68-pin VHDCI external SCSI port connects SCSI devices to the workstation. See SGI Supportfolio at <http://support.sgi.com> for an updated list of supported SCSI devices.

The rear panel of the optional second workstation enclosure has the following components:

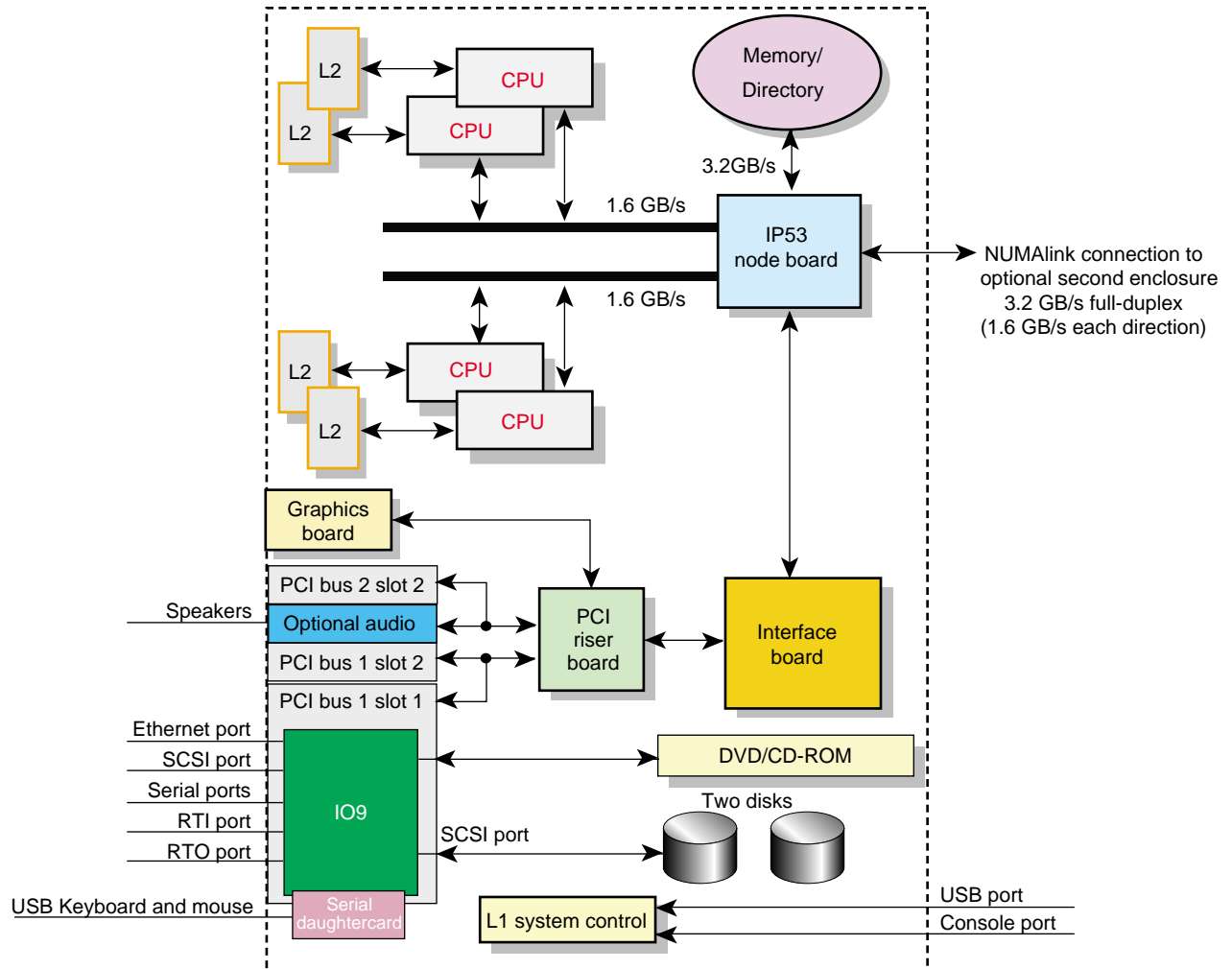
- **Power connector.** This connector connects the enclosure(s) to an AC power outlet.
- **Console port.** This DB-9 serial port (console and diagnostic port) enables you to connect a system console to the L1 controller.
- **Serial port 1.** This connector is not functional unless an IO9 board is installed in the enclosure. When an IO9 board is present, this DB-9 RS-232/RS-422 serial port connects a serial device to the workstation.
- **L1 port (USB type B).** This connector is not used.
- **NUMAlink connector.** This NUMAlink connector connects the two enclosures of a dual-enclosure workstation. This connection is made with a NUMAlink cable at 1.6 GB/s in each direction.
  - **NUMAlink LED.** The NUMAlink connector has LEDs that illuminate yellow and green (located to the right of the NUMAlink connector). The yellow LED indicates that the workstation enclosures are powered on. The green LED indicates that the connection between the enclosures is functioning.
- **PCI/PCI-X slots (bus 1, slot 1; bus 1, slot 2; bus 2, slot 1; bus 2, slot 2).** These slots are identical to those in the first enclosure.
- **Additional graphics or digital media option board.** The second enclosure may or may not contain a graphics or digital media option board.



**Figure 2-3** Rear Panel Components

## Internal Components

The rack-mountable workstation is based on a node board/interface board pair. The node board supplies connectivity and power to the memory DIMMs and processor(s). The remainder of the system components are connected to the interface board, as shown in Figure 2-4.



**Figure 2-4** System Architecture

The following sections contain more information about the internal components of the workstation:

- “Processors” on page 26
- “Memory DIMMs” on page 26
- “IO9 Board” on page 28
- “Internal Hard Disk Drives” on page 28
- “DVD-ROM Drive” on page 29
- “VPro™ Graphics Board” on page 30
- “PCI Busses” on page 30
- “Power Supply” on page 31

### Processors

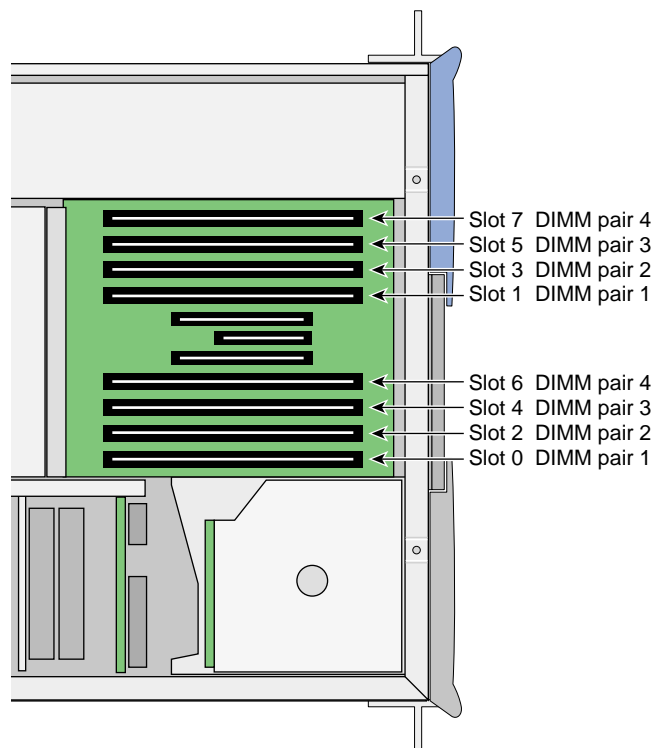
The first workstation enclosure is available with 1, 2, or 4 R16000 MIPS processors. Each processor has a total of 64 KB on-board cache. The processors also share a 4-MB external cache. The optional second enclosure does not contain any processors.

### Memory DIMMs

The single-enclosure workstation can be configured with a minimum of 512 MB of memory and a maximum of 8 GB of memory. The dual-enclosure workstation can be configured with up to 16 GB of memory. The rack-mountable workstation uses double data rate synchronous dynamic random access memory (DDR SDRAM).

The memory DIMMs are installed in eight DIMM sockets on the system node board. The DIMM sockets are numbered 0 through 7 (see Figure 2-5). The sockets are grouped into four pairs of two DIMMs. The DIMM pairs are numbered as follows:

- DIMM pair 1: slots 0 and 1
- DIMM pair 2: slots 2 and 3
- DIMM pair 3: slots 4 and 5
- DIMM pair 4: slots 6 and 7



**Figure 2-5** DIMM Sockets and Pairs

The following configuration rules apply to the memory banks and DIMMs in your system:

- DIMM pair 1 must be present.
- DIMMs in the same DIMM pair must be the same density. For example, if DIMM 0 is 512 MB, then DIMM 1 must be 512 MB.
- DIMMs must be installed in pairs.
- DIMM pairs should be added in sequence. For example, if there are DIMMs installed in pair 1, the next DIMMs should be installed in pair 2.
- The minimum amount of memory for a 1-processor workstation is 512 MB; the minimum for a 2- or 4-processor workstation is 1 GB.

- The maximum memory configuration for a single-enclosure workstation is 8 GB; dual-enclosure workstations have a maximum memory capacity of 16 GB.

For information on removing or installing memory DIMMs, see “Memory” on page 56.

### IO9 Board

The IO9 is the full-length PCI board installed in PCI bus 1, slot 1. It provides the following I/O connectors and interfaces for the workstation:

- Internal IDE connector for the optional DVD-ROM drive
- Internal SCSI connector for the hard disk drive(s)
- External SCSI connector for optional external drives
- Real-time interrupt in and out (RTI and RTO) connectors
- 10/100/1000BaseT Ethernet connector (RJ45)

The serial daughtercard, which provides three serial ports and two PS/2 ports on the rear of the workstation, is controlled by the IO9 board. The IO9 board also contains the NVRAM and time-of-day clock for the system.

Single-enclosure workstations are limited to one IO9 board. Dual-enclosure workstations may contain two IO9 boards, one in each enclosure. Adding a second IO9 board increases the number of hard-disk drives and other SCSI devices you can connect to the workstation.

For technical specifications and pinout of these connectors, see Appendix A, “Technical Specifications and Pinouts”.

### Internal Hard Disk Drives

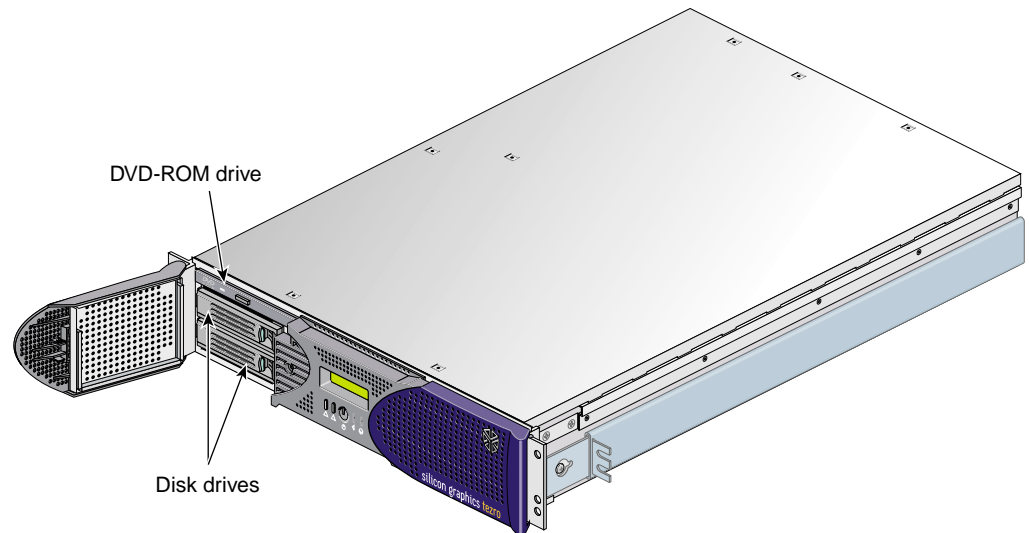
The rack-mountable workstation supports one or two internal hard disk drives, which are located on the left side of the front of the workstation (see Figure 2-6). These Ultra 160 SCSI drives provide large storage capacities and fast access times.

The hard disk drives in the workstation are sled mounted. The drive sleds provide a safe and easy way to install and remove the drives without tools. The drive sleds also provides a positive, locking connection to the SCSI backplane, which connects the disk drives to the IO9 board.

The disks are numbered 1 and 2, with 1 being the bottom disk and 2 being the top. The SCSI ID number of each disk must correspond with these drive numbers. Disk 1 is the system disk, which has the IRIX operating system installed on it. Your workstation will not function without the system disk.

**Note:** If a dual-enclosure workstation is equipped with two IO9 boards, it will support two additional hard disk drives in the second enclosure.

For information on removing or installing an internal hard disk drive, see “Disk Drives” on page 51.



**Figure 2-6** Internal Hard Disk Drives and DVD-ROM Drive

## DVD-ROM Drive

Your workstation supports an optional internal DVD-ROM drive. The DVD-ROM drive is capable of reading the following formats:

- DVD-RAM
- DVD-R
- Single layer (DVD-5)

- Dual layer (DVD-9)
- CD-ROM (audio and data)

The drive is installed in the half-height drive bay above the hard disk drives, as shown in Figure 2-6.

### VPro™ Graphics Board

The VPro graphics board is located at the rear of your workstation. It connects to the back side of the PCI riser board.

The VPro graphics board has the following features:

- 128 MB of onboard SDRAM.
- Analog RGB and TMDS video on a single DVI-I monitor port.
- Additional ports for Swap ready, Stereo View, and Genlock signals.

The VPro graphics board supports an optional Dual Channel Display (DCD-2) daughterboard is equipped with two DVI-I monitor ports. The daughterboard connects to the underside of the VPro graphics board and allows you to display data across two monitors at once. For more information about the optional Dual Channel Display daughterboard, contact your SGI sales representative or visit <http://www.sgi.com>.

For more information on the VPro graphics board and Dual Channel Display I/O ports, see “VPro™ Graphics Board I/O Port Specifications” in Appendix A.

### PCI Busses

The rack-mountable workstation provides slots for four 64-bit, 3.3-V PCI-X boards. The boards are installed in slots on the PCI riser board . The slots are divided into 2 busses:

- PCI bus 1 has two slots, numbered 1 and 2. Bus 1, slot 1 always contains the IO9 card.

---

**Note:** The IO9 board is a full-length PCI board that runs at 66 MHz. Installing a PCI-X board on the same bus as the IO9 will force the PCI-X board to run at 66 MHz.

---

- PCI Bus 2 has two slots, numbered 1 and 2.
- Bus 1, slot 1 is the lowest slot. Bus 2, slot 2 is the highest slot.



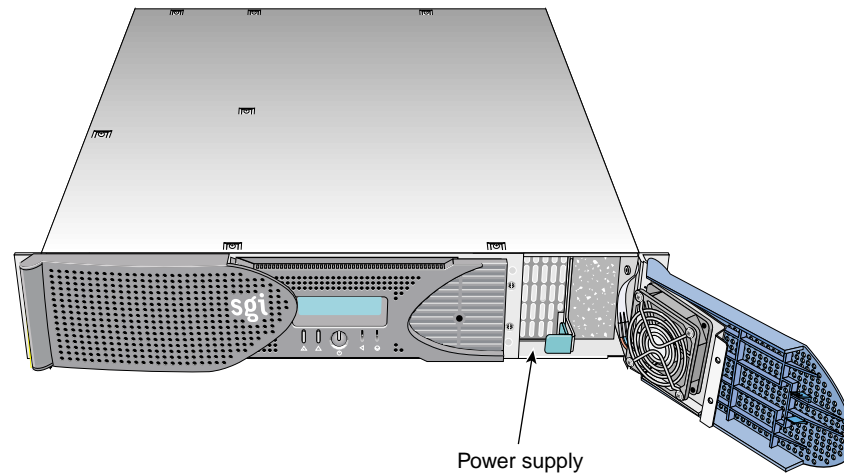
- These slots are labeled **PCI1**, **PCI2**, **PCI3**, and **PCI4** on the outside of the enclosure. **PCI1** corresponds to Bus 1, slot 1. **PCI4** corresponds to Bus 2, slot 2.

The optional second enclosure also contains a PCI riser board. The slot numbering and bus speeds are identical to those in the workstation. There may or may not be an IO9 installed in the second enclosure, depending on your configuration.

See “PCI Boards” on page 32 or contact your SGI sales representative for a list of available PCI boards.

## Power Supply

The power supply for the workstation is located in the right front corner of the chassis, as shown in Figure 2-7.



**Figure 2-7** Power Supply Location

The power supply accepts 110/220 VAC input and provides up to 500 watts of power at 12 VDC, 5 VDC, and -12 VDC. For detailed information about the power supply specifications, see Appendix A, “Technical Specifications and Pinouts.” For installation and removal instructions for the power supply, see “Power Supplies” on page 70.

## Optional Components, Peripherals, and Upgrades

Various optional components, peripherals, and upgrades are available for the rack-mountable workstation. The following sections give a brief overview of some of the available products:

- “PCI Boards” on page 32
- “Memory Upgrades” on page 33
- “Graphics Options” on page 33
- “Storage Options” on page 33
- “Displays” on page 34
- “Peripherals” on page 34

### PCI Boards

The following are some of the PCI boards that are available for your workstation:

- **SCSI boards:**  
Dual-port Ultra3 SCSI LVD or single-ended SCSI adapter
- **Fibre Channel boards:**  
Single-port 1-Gbit Fibre Channel board with optical or copper connector  
Single- and dual-port 2-Gbit Fibre Channel boards with optical connectors
- **Networking boards:**  
33- and 64-MHz, 64-bit single-port ATM boards  
1-port copper gigabit Ethernet adapter  
1-port 1000BaseSX gigabit Ethernet adapter  
66-MHz, 64-bit Myrinet NIC
- **Media boards:**  
DMediaPro DM8 Audio I/O PCI option  
DMediaPro DM9 professional Audio I/O option  
DMediaPro DM10 IEEE1394 Digital Audio/Video option  
DMediaPro DM3 High-definition and Standard-definition video I/O option

See SGI Supportfolio at <http://support.sgi.com> for an updated list of available cards.

## Memory Upgrades

The following memory upgrades are available for the workstation:

- 512-MB DIMM pair
- 1-GB DIMM pair
- 2-GB DIMM pair

---

**Note:** The single-enclosure workstation supports a maximum of eight memory DIMMs totalling eight GB. The dual-enclosure workstation can contain sixteen memory DIMMs, totalling 16 GB. Memory DIMMs must be installed in pairs of the same size.

---

## Graphics Options

The following are some of the optional graphics components available with your workstation:

- **Dual-Channel Display (DCD-2) daughterboard.** This card attaches to the graphics board and allows data to be displayed across two monitors. It has two DVI-I video ports.
- **Dual-head VPro™ graphics option.** Dual-enclosure workstations can be configured with a second VPro graphics board.

## Storage Options

The following storage upgrades are available for the workstation:

- Additional Internal Ultra SCSI hard disk drives
- External SCSI DAT drive
- External CD-ROM drive
- Internal DVD-ROM drive

In addition to the items listed above, various other storage solutions are available from SGI. For more information, contact your SGI sales representative.

## Displays

The following displays are available with the workstation:

- 21-in. SGI cathode ray tube (CRT) monitor
- 24-in. SGI CRT monitor
- Silicon Graphics F180 (18.1-in. flat panel monitor)
- Silicon Graphics F220 (22-in. wide-aspect-ratio flat panel monitor)

## Peripherals

The following peripherals are available with the workstation:

- 3-button mouse
- Beeping keyboard
- Speakers
- Spaceball programmable trackball

For a complete list of available components, contact your SGI sales representative or see the following website:

<http://www.sgi.com/peripherals/workstation/index.html>

## Installing and Removing Customer-replaceable Units

This chapter provides safety instructions to follow when using and maintaining your workstation. It also describes how to install and remove the workstation's customer-replaceable units (CRUs). This information is covered in the following sections:

- "Safety Instructions" on page 35
- "Accessing Internal System Components" on page 38
- "PCI and PCI-X Cards" on page 39
- "Disk Drives" on page 51
- "Memory" on page 56
- "L1 Controller Display" on page 65
- "Power Supplies" on page 70

### Safety Instructions

Before you perform any type of maintenance to your system, read the following safety instructions:

- Follow all warnings and instructions marked on the product and noted in this and other documentation included with the product.
- Unplug this product from the wall outlet before you clean it. Do not use liquid cleaners or aerosol cleaners. Use a damp cloth for cleaning.
- Do not use this product near water.
- Do not place this product or components of this product on an unstable cart, stand, or table. The product may fall, causing serious damage to the product.
- Slots and openings on the cabinet and components are provided for ventilation, reliable operation, and protection from overheating of the product. These slots and

openings must not be blocked or covered. This product should never be placed near or over a radiator or heat register, or in a built-in installation unless proper ventilation is provided.

- This product should be operated from the type of power indicated on the marking label. If you are not sure of the type of power available, consult your dealer or local power company.
- Do not allow anything to rest on the power cord. Do not locate this product where persons will walk on the cord.
- Do not use extension cords with your SGI system.
- Never push objects of any kind into this product through cabinet slots because they may touch dangerous voltage points or short out parts that could result in a fire or electric shock.
- Never spill liquid of any kind on the product.
- Do not attempt to service this product yourself except as noted in this guide. Opening or removing covers of internal components may expose you to dangerous voltage points or other risks. Refer all servicing to qualified service personnel.
- Unplug this product from the wall outlet and refer servicing to qualified service personnel under the following conditions:
  - If the power cord or plug is damaged or frayed.
  - If the product has been exposed to rain, water, or other type of liquid.
  - If the product does not operate normally when the operating instructions are followed.

---

**Note:** Adjust only those controls that are covered by the operating instructions, because improper adjustment of other controls may result in damage and will often require extensive work by a qualified technician to restore the product to normal condition.

---

- If the product has been dropped or the cabinet has been damaged.
- If the product exhibits a distinct change in performance, which indicates a need for service.
- Only qualified service personnel should replace a soldered lithium battery in the workstation, and only with the same type or an equivalent type recommended by

the manufacturer. Please see the “Lithium Battery Statement” on page 127 for more information. The battery can explode if it is replaced incorrectly.

- Use only the proper type of power supply cord set (provided with the system) for this unit.



---

**Caution:** Electronic equipment can be irreparably damaged by electrostatic discharge (ESD). Always follow these preventive measures when you handle a system component:

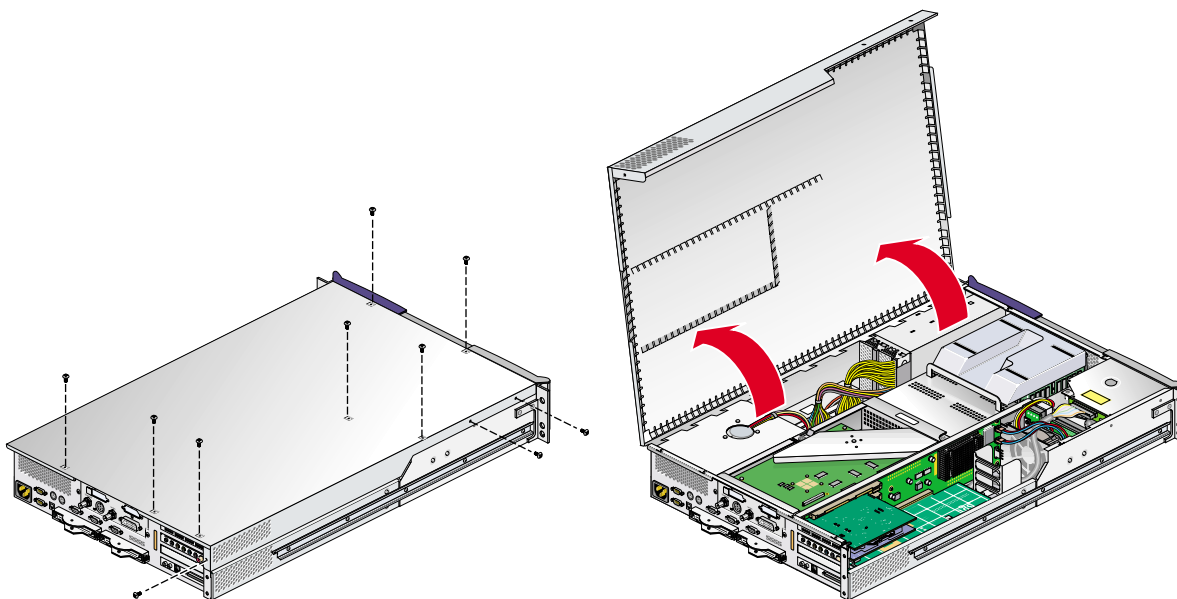
- Remove a component from its antistatic bag only when you are ready to install it.
- If you handle a component before installation, do not place it on surfaces that produce ESD (carpeting, for example) or near devices that create static electricity.
- Attach a static wrist strap to a grounded connection on your system when you install or remove a component.

---

## Accessing Internal System Components

To access and remove/replace internal system components, follow these steps to remove and replace the enclosure cover:

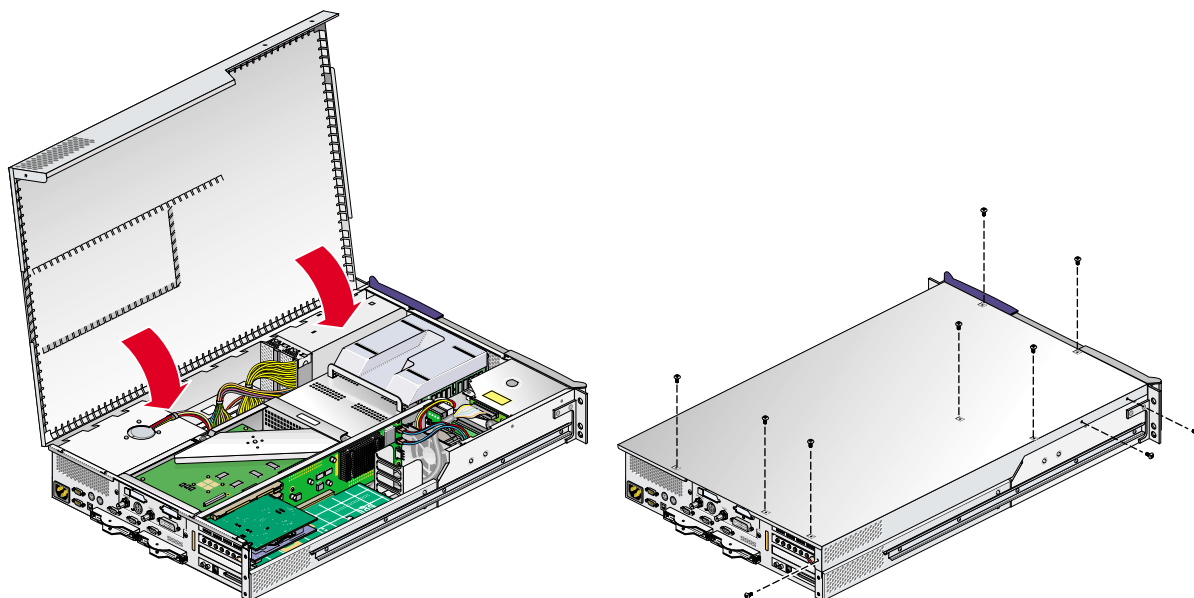
1. Unfasten the two screws that hold the enclosure in the rack.
2. Use two people to slide it out and set it on a table or other stable work surface.
3. Remove the ten Phillips screws as shown in Figure 3-1 and lift the hinged cover.



**Figure 3-1** Removing the Enclosure Top Cover Screws

4. Follow the instructions in this chapter for adding/removing the internal components such as PCI cards or memory DIMMs.
5. After completing the procedure(s) needed, close and secure the enclosure by replacing the cover and tightening the ten screws as shown in Figure 3-2.
6. Using two people, insert the enclosure back into the rack and secure it with the two screws you removed in step 1.





**Figure 3-2** Closing and Replacing the Enclosure's Top Cover

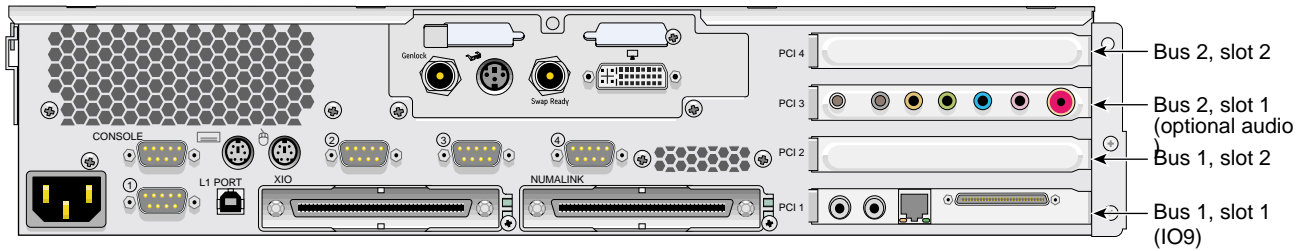
## PCI and PCI-X Cards

The rack-mountable workstation supports PCI and PCI-X cards. The following procedure describes how to install and remove a PCI or PCI-X card from a workstation. This procedure applies to both the first enclosure and the optional second enclosure. Figure 3-3 shows the location of the PCI and PCI-X card slots in both the first and second enclosures.

For an updated list of supported PCI and PCI-X cards, see SGI Supportfolio at <http://support.sgi.com>.

This section explains how to perform the following procedures:

- "Installing a Card" on page 40
- "Removing a Card" on page 45



**Figure 3-3** PCI and PCI-X Card Slots Located in the Rear Panel

## Installing a Card

To install a PCI or PCI-X card, follow these steps:

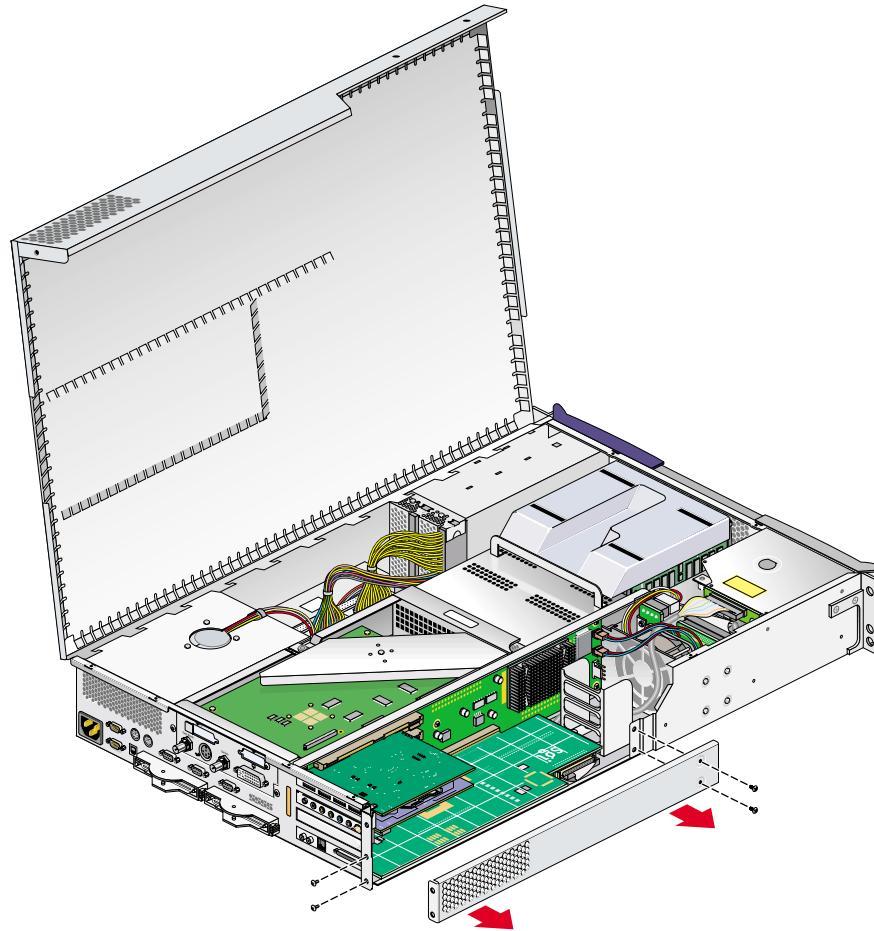
1. Power off the system. For instructions on how to power off the system, see “Using the Workstation” in Chapter 1.
2. Disconnect all of the cables at the rear of the system.



**Warning:** Components may be hot. To avoid injury, allow the components to cool for approximately five minutes before you proceed with these instructions.

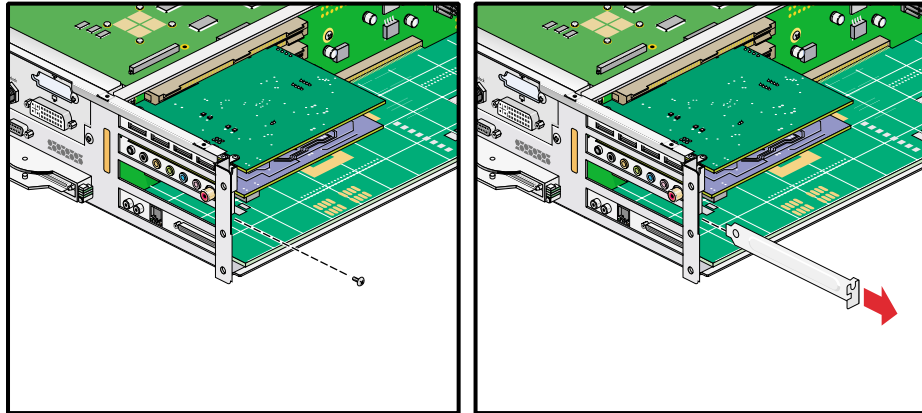
3. If your system is rackmounted, remove the two screws that secure the enclosure to the front rails of the rack. If your system is not rackmounted, proceed to the next step.

4. If you are installing a card in one of the two lowermost card slots, you must also remove the lower PCI/PCI-X support bracket that covers the two lowermost slots as shown in Figure 3-4 by removing the four Phillips screws.



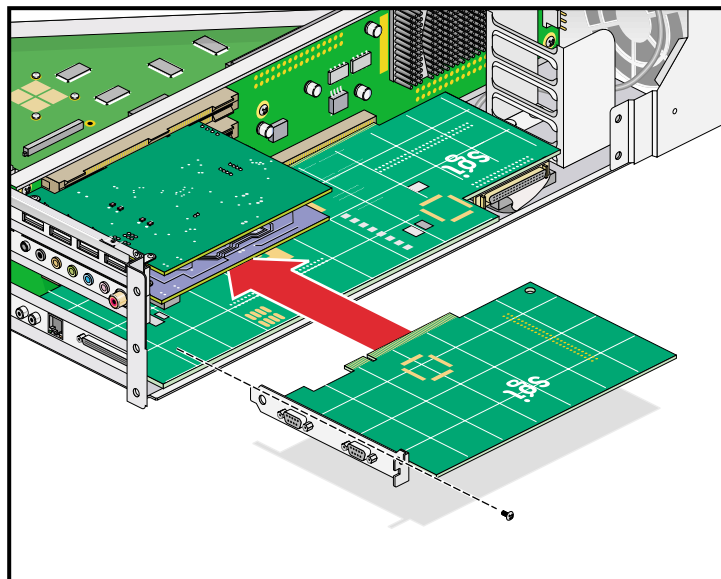
**Figure 3-4** Removing the Lower PCI/PCI-X Support Bracket

5. If a blanking plate covers the slot that is needed for the installation, remove the retaining screw as shown in Figure 3-5 and the blanking plate.



**Figure 3-5** Removing a Blanking Plate

6. If you want to install a PCI/PCI-X card, insert the card into the slot by pushing the card into the connector until it is properly seated and install the retaining screw as shown in Figure 3-6. If you have installed a card (not an IO9 card) into one of the two lowermost slots, proceed to step 12. If you have installed the card into one of the upper two slots, proceed to step 14.

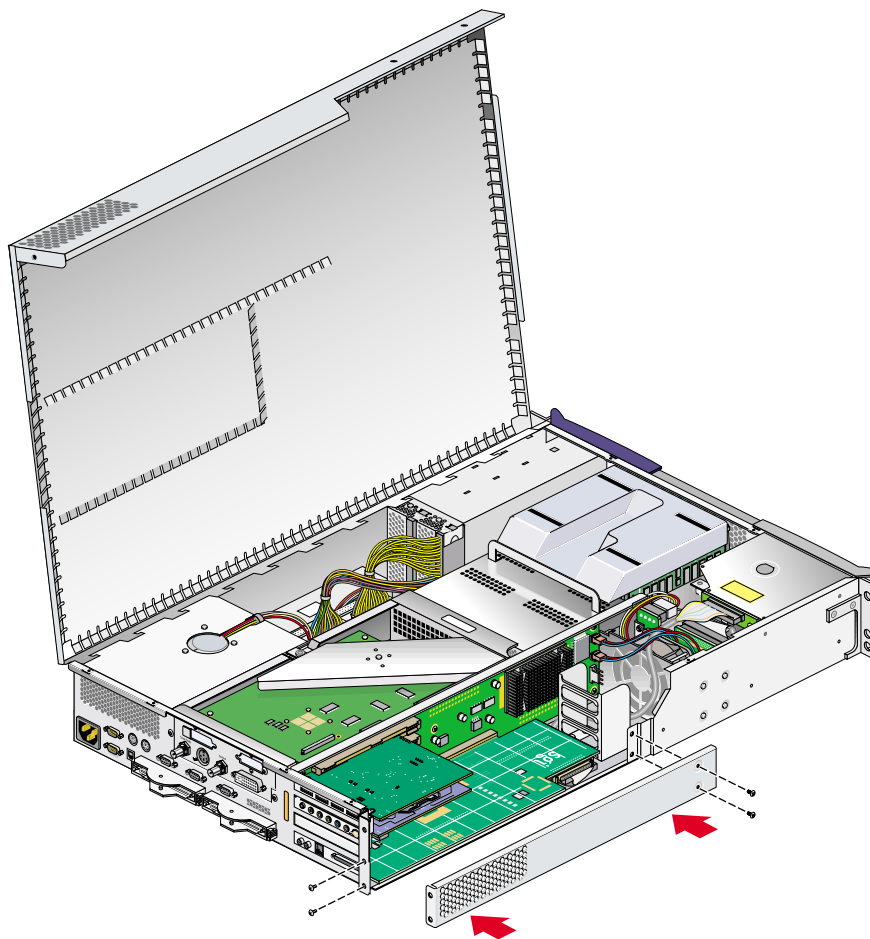


**Figure 3-6** Installing the Card and Retaining Screw

7. If you have installed a card in one of the two bottom-most card slots, replace the lower PCI/PCI-X support bracket that covers the two bottom-most slots and screw in the four Phillips screws as shown in Figure 3-7.



**Caution:** To prevent pinching and damaging of the IDE and SCSI cables, make sure that both of these cables are tucked underneath the IO9 card and safely away from the lower PCI/PCI-X support bracket that you are replacing.



**Figure 3-7** Replacing the Lower PCI/PCI-X Support Bracket

8. Close the hinged cover on the system and screw in the ten Phillips screws you removed to secure the cover as shown in Figure 3-2 on page 39.
9. If your system is rackmounted, proceed to the next step. If your system is free-standing, proceed to step 13.
10. Using two people, slide the enclosure back into the rack.
11. Install the two screws that secure the enclosure to the front rails of the rack.
12. Install the two screws that secure the enclosure to the rear of the rack.
13. Install all of the cables at the rear of the system.
14. Power on the system. For instructions on how to power on the system, see “Using the Workstation” in Chapter 1.

## Removing a Card

To remove a PCI or PCI-X card, follow these steps:

1. Power off the system. For instructions on how to power off the system, see “Using the Workstation” in Chapter 1.
2. Disconnect all of the cables at the rear of the system.



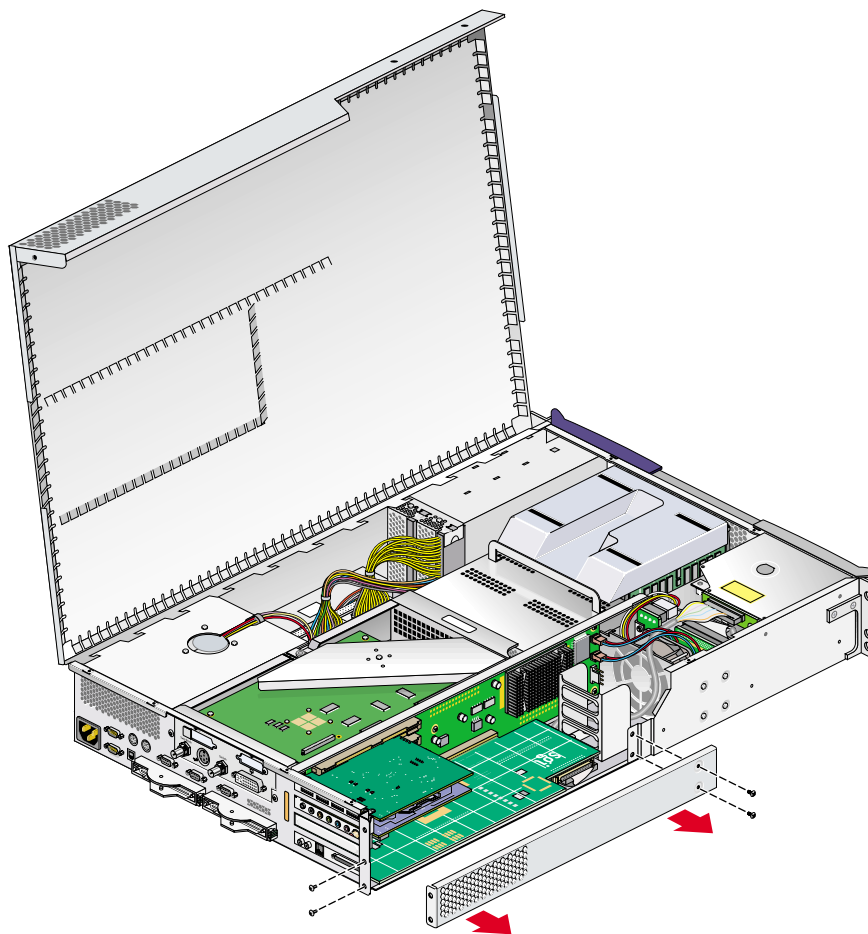
---

**Warning:** Components may be hot. To avoid injury, allow the components to cool for approximately five minutes before you proceed with these instructions.

---

3. Remove the two screws that secure the enclosure to the front rails of the rack.
4. Remove the two screws that secure the enclosure to the rear of the rack.
5. Using two people, pull the enclosure from the rack and move it to a table or other stable work area.
6. To access the PCI cards, first remove the ten Phillips screws as shown in Figure 7-1 on page 131, and then lift the hinged cover.

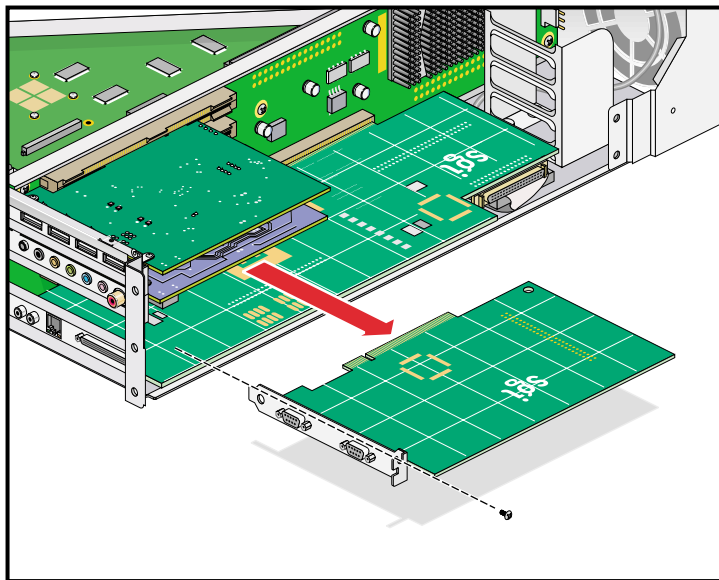
7. If you are removing a card from one of the two lowermost slots, you must also remove the lower PCI/PCI-X support bracket that covers the two lowermost slots by unscrewing the four Phillips screws shown in Figure 3-8.



**Figure 3-8** Removing the Lower PCI/PCI-X Support Bracket

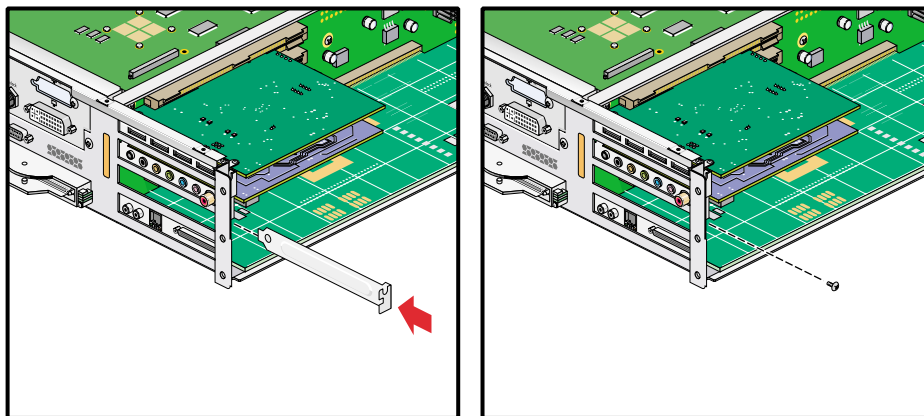


8. If you are removing a card from one of the upper three slots, unscrew the retaining screw and extract the card as shown in Figure 3-9. Place the card on an ESD-safe surface. (If you are removing a card from one of the upper two slots, after you have removed the card, proceed to step 12. Otherwise, proceed to the next step.)



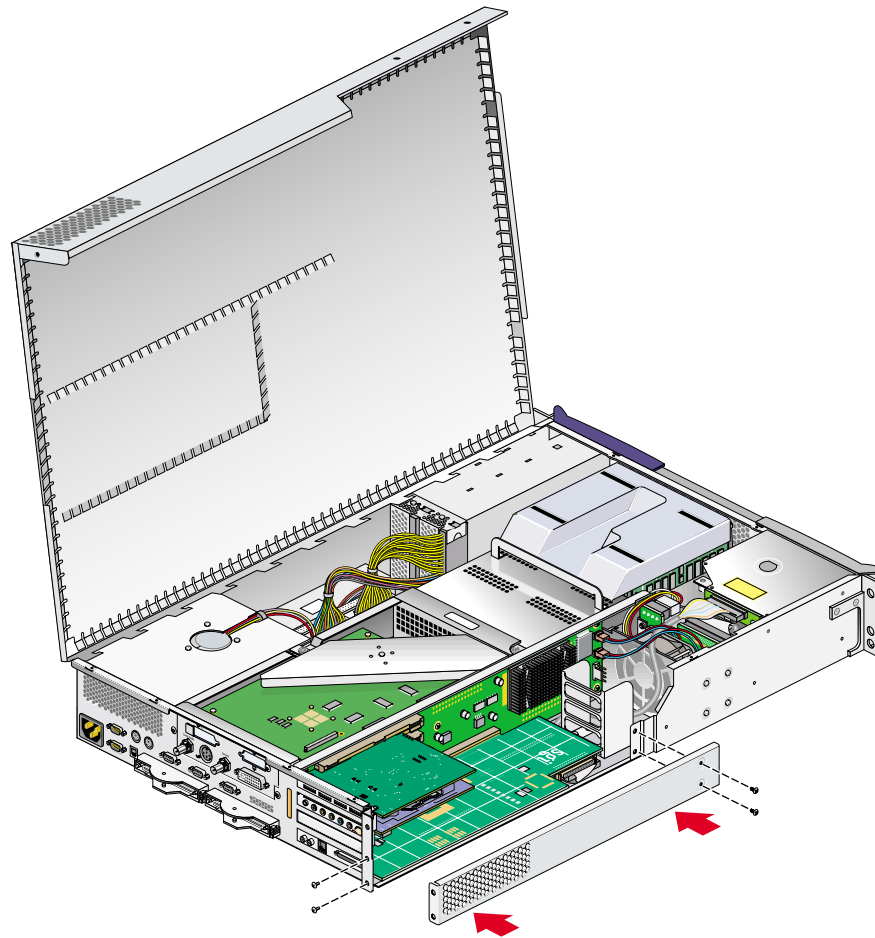
**Figure 3-9** Removing the Retaining Screw and Extracting the Card

9. If you are replacing the card you have removed, proceed to “Installing a Card” on page 40. Start with step 10 in that procedure to begin the card replacement. If you are not replacing the card you have removed, proceed to the next step.
10. If you have removed a card from one of the upper three slots, place a blanking plate to cover the slot and screw in the retaining screw as shown in Figure 3-10. After installing the blanking plate, if you have removed a card from one of the two lowermost slots, proceed to the next step. Otherwise, proceed to step 15.



**Figure 3-10** Placing a Blanking Plate

11. If you have removed a card from one of the two bottom-most card slots, replace the lower PCI-PCI-X support bracket that covers the two bottom-most slots, and screw in the four Phillips screws as shown in Figure 3-11.



**Figure 3-11** Replacing the Lower PCI/PCI-X Support Bracket

12. Close the hinged cover on the system and screw in the ten Phillips screws, which you had removed as shown in Figure 3-2 on page 39, to secure the cover.
13. If your system is rackmounted, proceed to the next step. If your system is free-standing, proceed to step 17.
14. Using two people, slide the enclosure back into the rack.
15. Install the two screws that secure the enclosure to the front rails of the rack.
16. Install the two screws that secure the enclosure to the rear of the rack.
17. Install all of the cables at the rear of the system.
18. Power on the system. If you need instructions on how to power on the system, see “Using the Workstation” in Chapter 1.

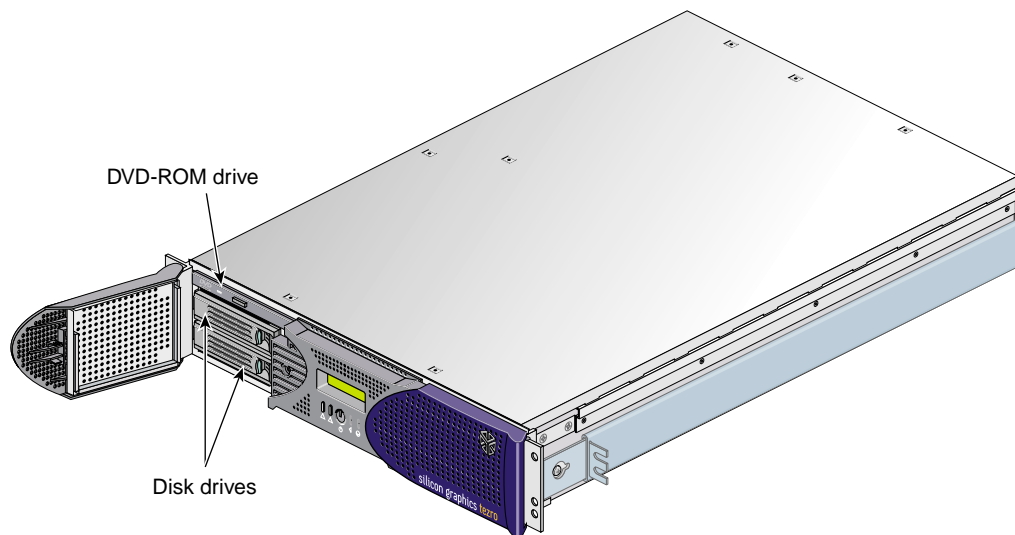
## Disk Drives

Each workstation enclosure can contain one or two sled-mounted Ultra 160 SCSI disk drives (see Figure 3-12). This section explains how to install and remove a disk drive.

---

**Note:** The second enclosure in a dual-enclosure workstation must have an IO9 card in order to support disk drives.

---



**Figure 3-12** Disk Drive Location

## Installing a Disk Drive

To install a disk drive, follow these steps:

1. Open the bezel door as far as it will open. Position the drive assembly so that it engages the bay guide rails and, with the locking handle fully swung open, gently push in the drive into the bay until the locking handle engages with left side of the bay opening as shown in Figure 3-13A.

---

**Note:** If you will have only one disk drive in your system, it should be located in the bottom-most slot.

---

2. Swing the locking handle towards the chassis until the locking handle engages the latch as shown in Figure 3-13B and Figure 3-13C.
3. Close the bezel door as shown in Figure 3-13D.

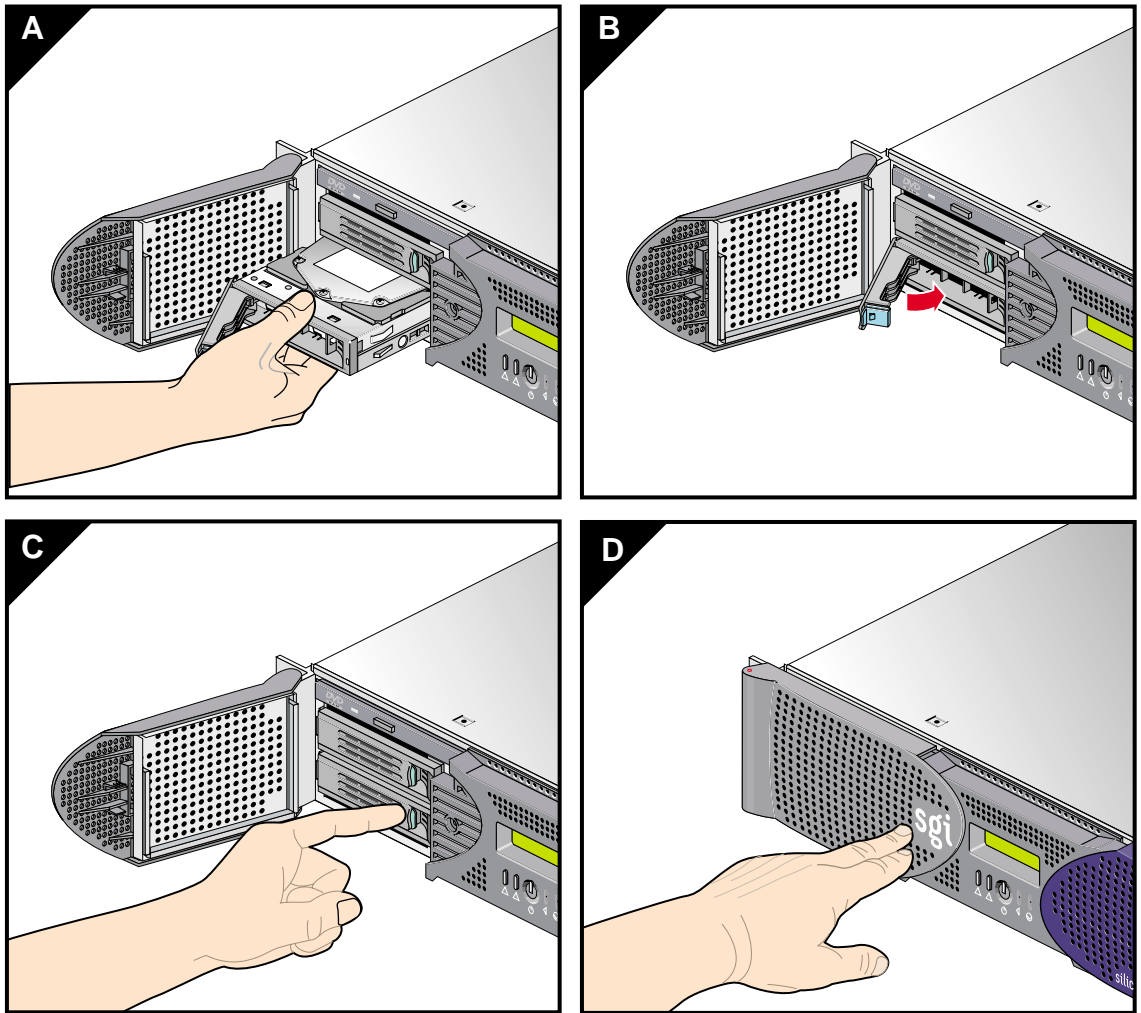


Figure 3-13 Installing a Disk Drive

## Removing a Disk Drive

To remove a disk drive, follow these steps:

1. If you are replacing a data drive, ensure that the drive has spun down before you remove it.
2. If you are replacing the system drive, you must first halt the operating system using a command such as `/etc/shutdown` or `/etc/halt` and then power off the system.
3. Open the bezel door located on the left side of the front panel of the enclosure as shown in Figure 3-14A. (Make sure that you open the door as far as it will open.)
4. Remove the drive by depressing the locking handle with your forefinger (see Figure 3-14B) and swing open the locking handle away from the chassis until the handle disengages the drive connector from the backplane connector (see Figure 3-14C).

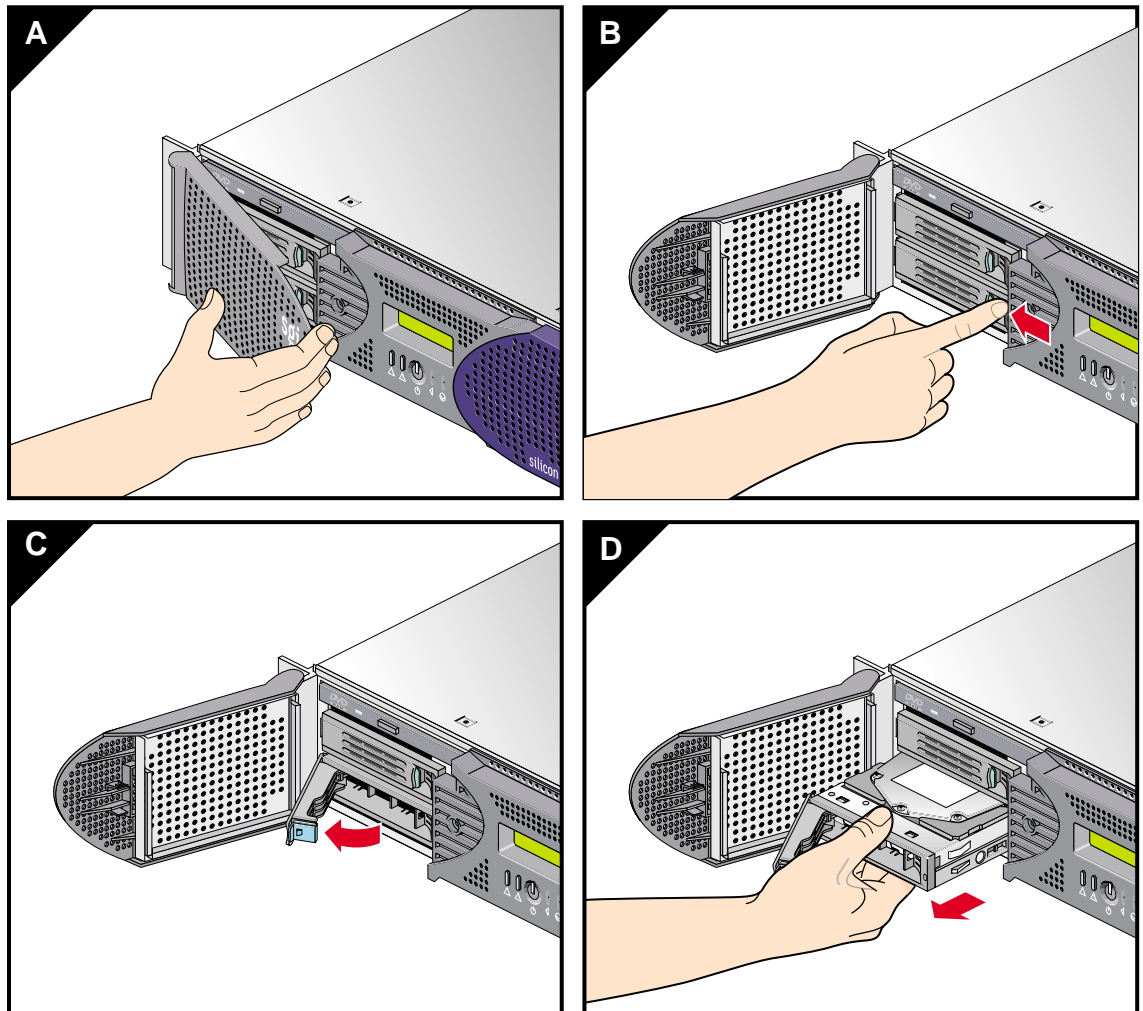
---

**Note:** If you will have only one disk drive, it should be located in the bottom-most slot.

---

5. Carefully slide the drive out of the bay (see Figure 3-14D) and gently place it on a flat ESD-safe surface. (Do not use the handle to pull the drive out of the bay.)
6. If you are replacing the disk drive, proceed to “Installing a Disk Drive” on page 52, for installation instructions. (After you have replaced the disk drive, return to step 8 for instructions to power on your system.) If you are not replacing the disk drive, proceed to the next step.
7. Close the bezel door.
8. Power on the system.





**Figure 3-14** Removing a Disk Drive

## Memory

Memory is contained on cards that are referred to as DIMMs (dual inline memory modules). Each workstation enclosure can contain two, four, six, or eight DIMMs. The DIMMs are installed in eight slots located on the system node board.

These eight DIMM slots are organized into a group of even-numbered slots 0, 2, 4, and 6 and a group of odd-numbered slots 1, 3, 5, and 7, as shown in Figure 3-15 on page 57.

DIMMs are installed one per DIMM slot, and two at a time, so that the two DIMMs installed provide local memory for the same pair of banks. For example, you can install a DIMM in slot 0 and another in slot 1 (this adds memory to bank pairs 0 and 1). Table 3-1 lists the DIMM slots and the corresponding bank pairs to which local memory is provided when DIMMs are installed:

**Table 3-1** DIMMs and Bank Pairs

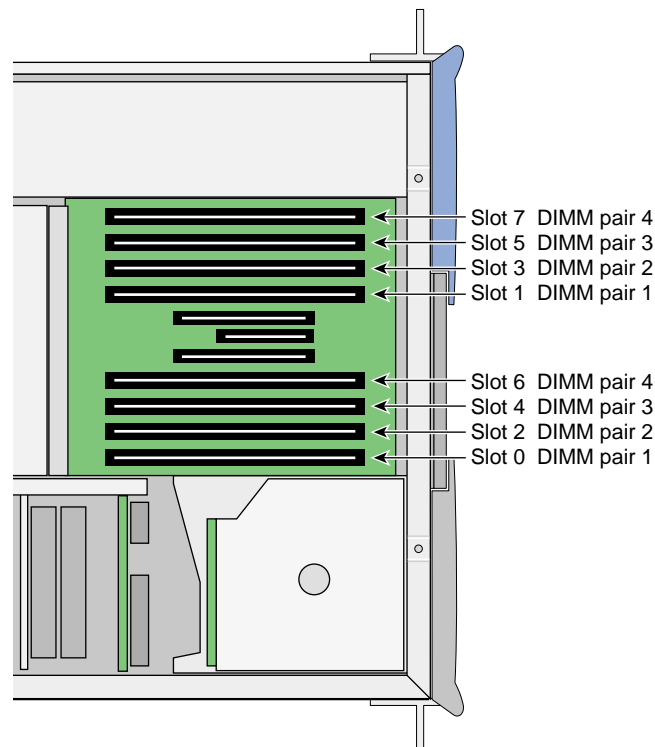
DIMM in Slot Number	Provides Local Memory for Bank Pair Numbers
0 <sup>a</sup>	0 and 1
1	0 and 1
2	2 and 3
3	2 and 3
4	4 and 5
5	4 and 5
6	6 and 7
7	6 and 7

a. The first two DIMMs must be installed in DIMM slot 0 and DIMM slot 1.

When installing DIMMs, you must follow these guidelines:

- Memory is increased or decreased in two-DIMM increments only.
- The two DIMMs that make up a bank pair must be the same memory size; however, each pair of DIMMs can be a different memory size from another pair.

- The first two DIMMs must be installed in DIMM slot 0 and DIMM slot 1. Subsequent DIMM pairs can be installed in any order, but for consistency they should be installed in the next available DIMM slots.
- The DIMMs used in the rack-mountable workstation are not compatible with the DIMMs used in Origin 200, SGI 2000 series, Onyx2, or Octane systems.
- The workstation supports the following memory kits:
  - 512-MB kit with integrated directory memory.
  - 1-GB kit with integrated directory memory.
  - 2-GB kit with integrated directory memory.



**Figure 3-15** Layout of DIMM Slots and Local Memory Banks



---

**Caution:** Electronic equipment can be irreparably damaged by electrostatic discharge (ESD). Always follow these preventive measures when you handle a system component:

- Remove a component from its antistatic bag only when you are ready to install it.
  - If you handle a component before installation, do not place it on surfaces that produce ESD (carpeting, for example) or near devices that create static electricity.
  - Attach a static wrist strap to a grounded connection on your system when you install or remove a component.
- 

## Installing a DIMM

To install a DIMM, follow these steps:

1. Power off the system. For instructions on how to power off the system, see “Using the Workstation” in Chapter 1.
2. Disconnect all of the cables at the rear of the system.
3. Remove the two screws that secure the enclosure to the rear of the rack.



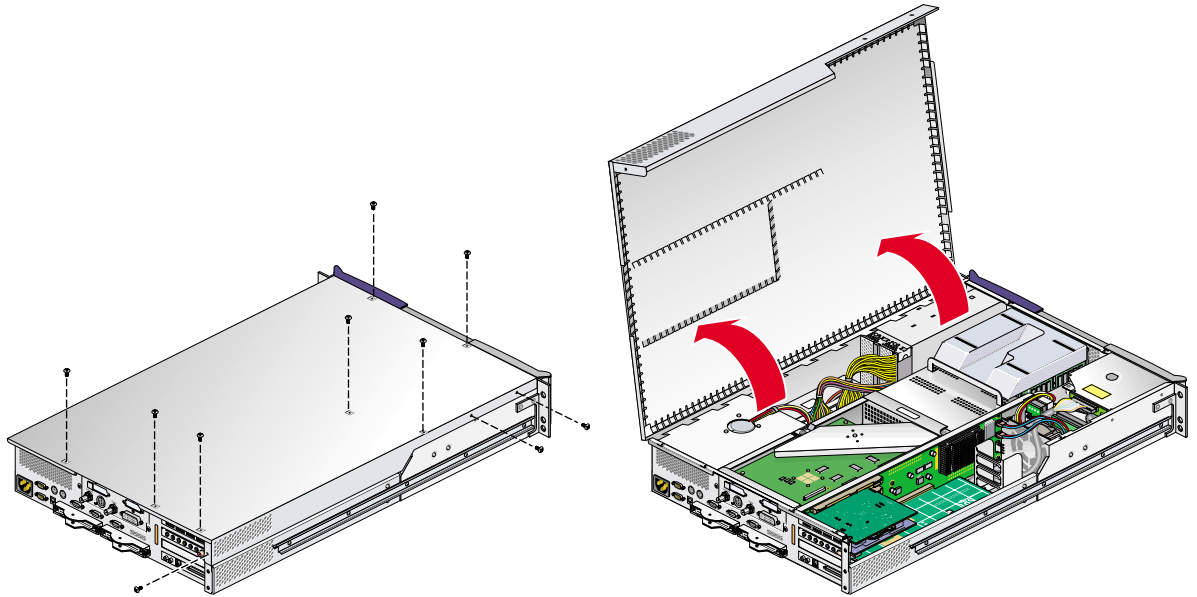
---

**Warning:** Components may be hot. To avoid injury, allow the components to cool for approximately 5 minutes before you proceed with these instructions.

---

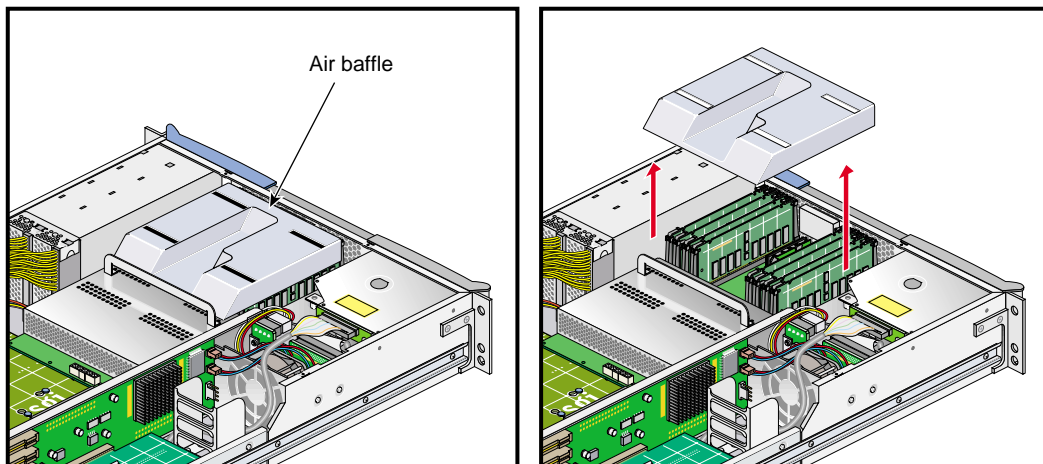
4. Remove the two screws that secure the enclosure to the front rails of the rack.
5. Using two people, pull the enclosure from the rack and move it to a tabletop or other sturdy work surface.

- To access the DIMMs, remove the ten Phillips screws shown in Figure 3-16 and lift and open the hinged cover.



**Figure 3-16** Opening the Enclosure Cover to Install DIMMs

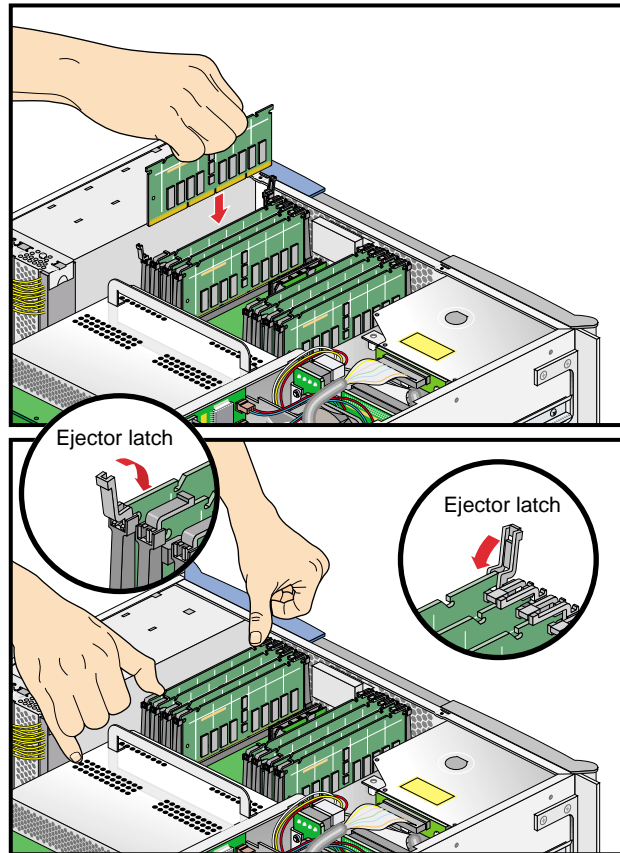
7. Remove the plastic air baffle covering the DIMMs as shown in Figure 3-17.



**Figure 3-17** Removing the Plastic Air Baffle

8. Install the DIMM, as follows (see Figure 3-18):
  - a. Open the ejector latches.
  - b. Hold the DIMM only by its edges and remove it from its antistatic package.
  - c. Align the three notches in the bottom edge of the DIMM with the keyed socket.
  - d. Insert the bottom edge of the DIMM into the socket, and then press down on the DIMM until it seats correctly. Use extreme care when you install a DIMM. If you apply too much pressure, you can damage the socket.
  - e. Gently push the plastic ejector latches down to secure the DIMM, as shown in Figure 3-18. When the DIMM is fully seated in the connector, the ejector latches snap into place.
9. Replace the plastic air baffle.
10. Attach the hinged cover and secure it to the with ten Phillips screws.
11. If your system is rackmounted, proceed to the next step. If your system is free-standing, proceed to step 15.
12. Slide the enclosure back into the rack.
13. Install the two screws that secure the enclosure to the front rails of the rack.
14. Install the two screws that secure the enclosure to the rear of the rack.
15. Reconnect all of the cables at the rear of the system.

16. Power on the system. For instructions on how to power on the system, see “Using the Workstation” in Chapter 1.



**Figure 3-18** Inserting a DIMM

## Removing a DIMM

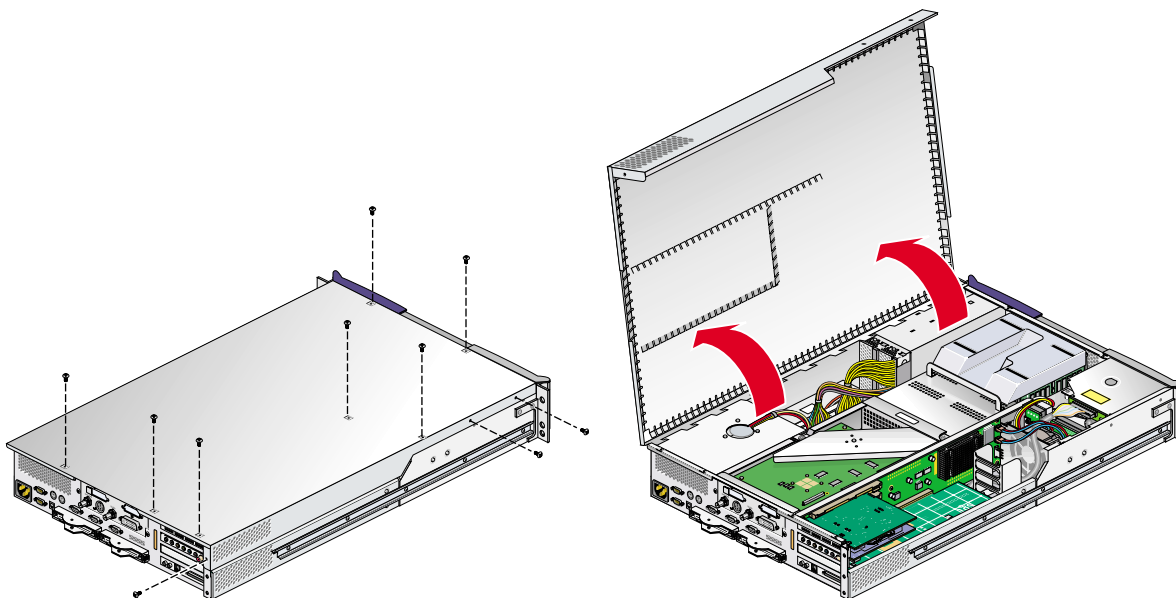
To remove a DIMM, follow these steps:

1. Power off the system. For instructions on how to power off the system, see “Using the Workstation” in Chapter 1.
2. Disconnect all of the cables at the rear of the system.
3. Remove the two screws that secure the enclosure to the rear of the rack.



**Warning:** Components may be hot. To avoid injury, allow the components to cool for approximately five minutes before you proceed with these instructions.

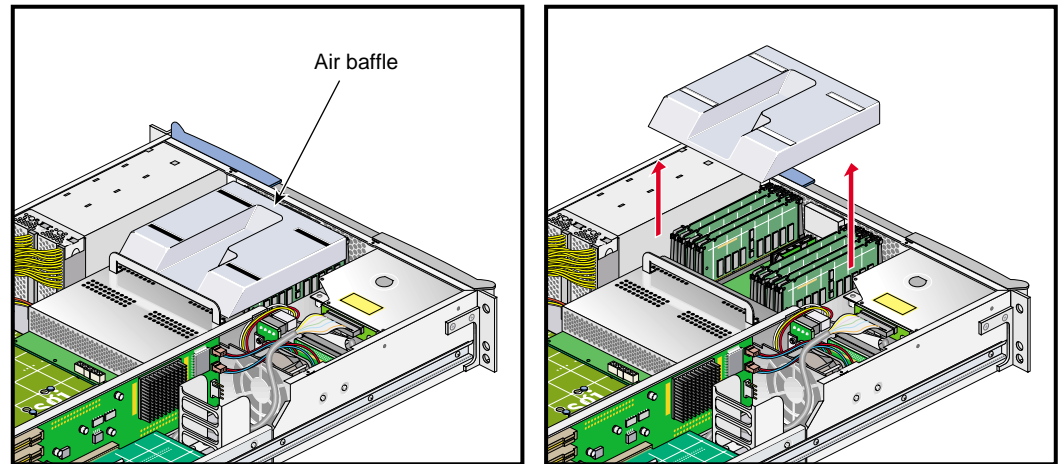
4. Remove the two screws that secure the enclosure to the front rails of the rack.
5. Using two people, pull the enclosure from the rack and move it to a table top or other sturdy work surface.
6. To access the DIMMs, remove the ten Phillips screws shown in Figure 3-19 and open the hinged cover.



**Figure 3-19** Opening the Enclosure



7. Remove the plastic air baffle covering the DIMMs as shown in Figure 3-20.



**Figure 3-20** Removing the Plastic Air Baffle

8. Remove the DIMM, as follows (see Figure 3-21):
  - a. Lift the two ejector latches simultaneously to disengage the DIMM from its connector.
  - b. Carefully grasp the DIMM and pull it up and out of the guide rails.

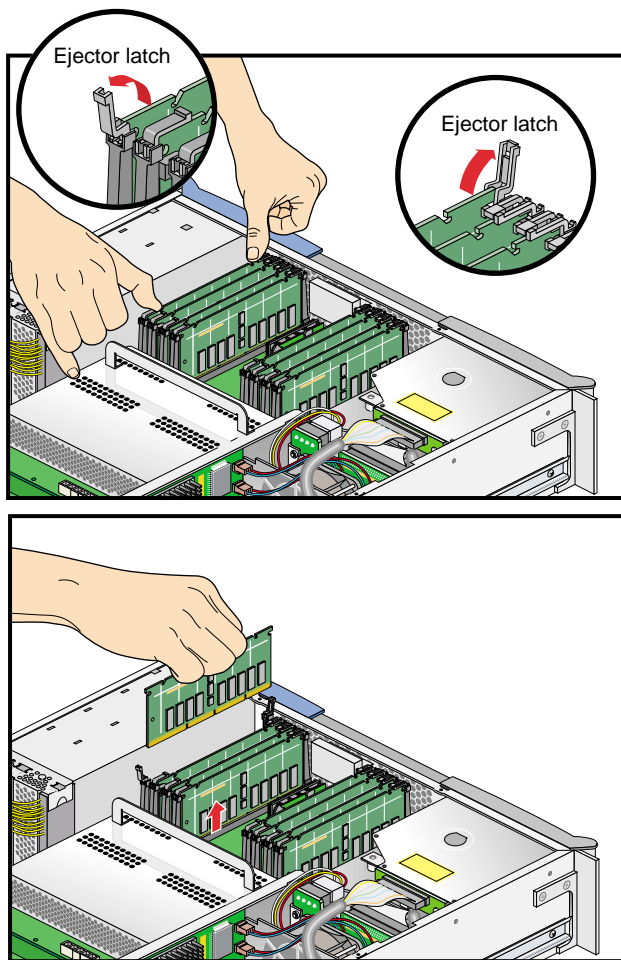
---

**Note:** Hold the DIMM only by its edges. Be careful not to touch its components or gold edge connectors.

---

- c. Place the DIMM on an ESD-safe surface.
9. Insert a new DIMM as described in “Installing a DIMM” on page 58.
10. Replace the plastic air baffle.
11. Attach or close the hinged cover and secure it with the ten Phillips screws.
12. If your system is rackmounted, proceed to the next step. If your system is free-standing, proceed to step 15.
13. Using two people, slide the enclosure back into the rack.
14. Install the two screws that secure the enclosure to the front rails of the rack.
15. Reconnect all of the cables at the rear of the system.

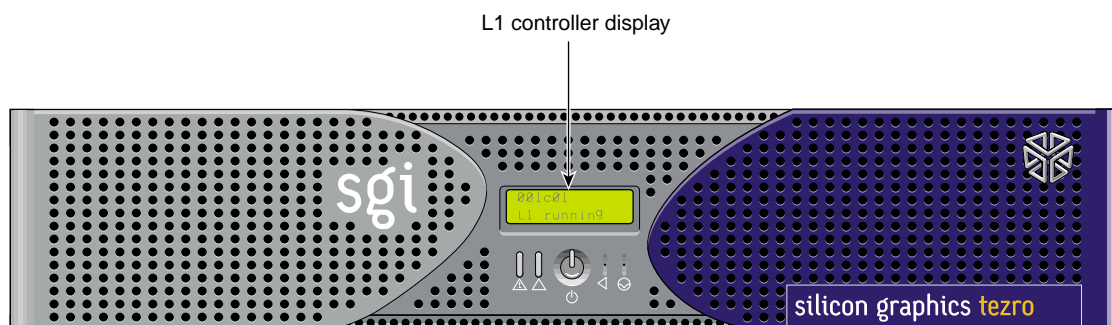
16. Power on the system. For instructions on how to power on the system, see “Using the Workstation” in Chapter 1.



**Figure 3-21** Removing a DIMM

## L1 Controller Display

The L1 controller, which is used to monitor and manage the workstation, has a display located on the front panel as shown in Figure 3-22. Every workstation enclosure is factory shipped with an L1 controller display. This section describes how to replace an L1 controller display panel.



**Figure 3-22** L1 Controller Display on the Front Panel

To replace an L1 controller display, follow these steps:

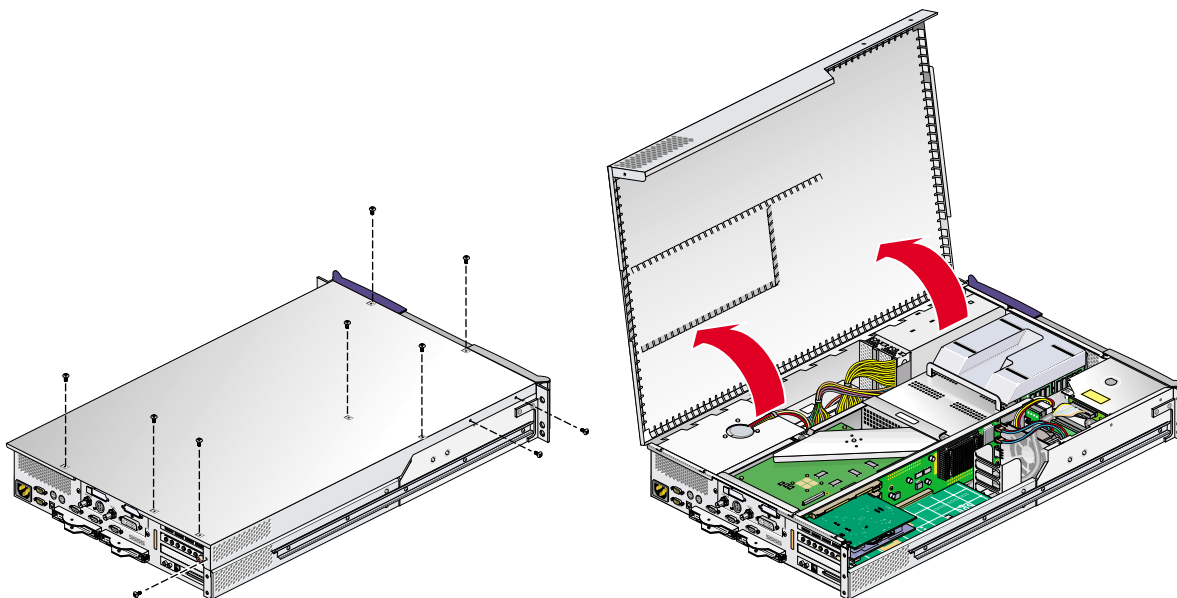
1. Power off the system. For instructions on how to power off the system, see “Using the Workstation” in Chapter 1.
2. Disconnect all of the cables at the rear of the system.



**Warning:** Components may be hot. To avoid injury, allow the components to cool for approximately five minutes before you proceed with these instructions.

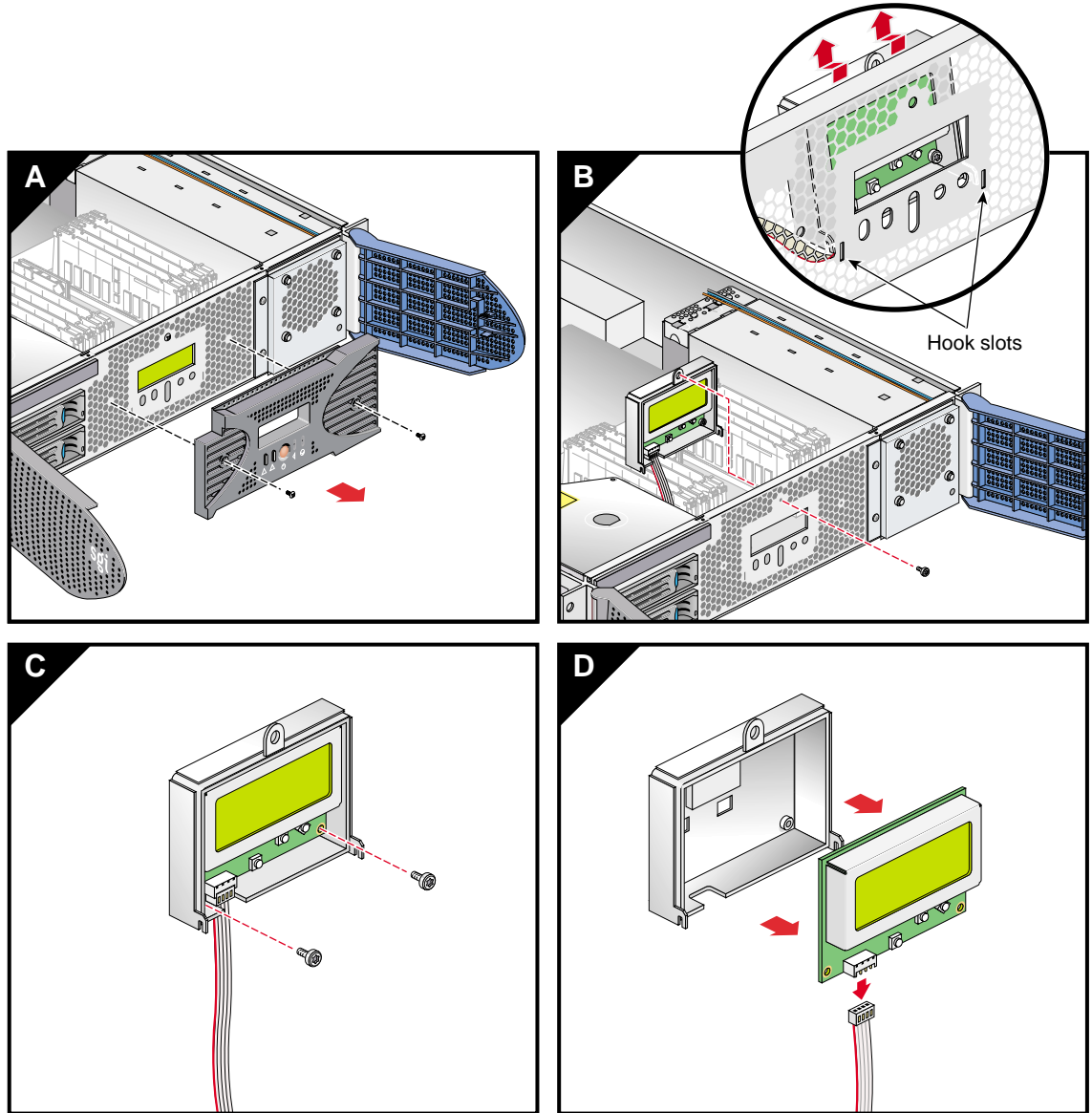
3. Remove the two screws that secure the enclosure to the front rails of the rack.
4. Using two people, pull the enclosure from the rack and move it to a tabletop or other sturdy work surface.

5. To access the area where the L1 display is replaced, remove the ten Phillips screws shown in Figure 3-23 and lift and open the hinged cover.



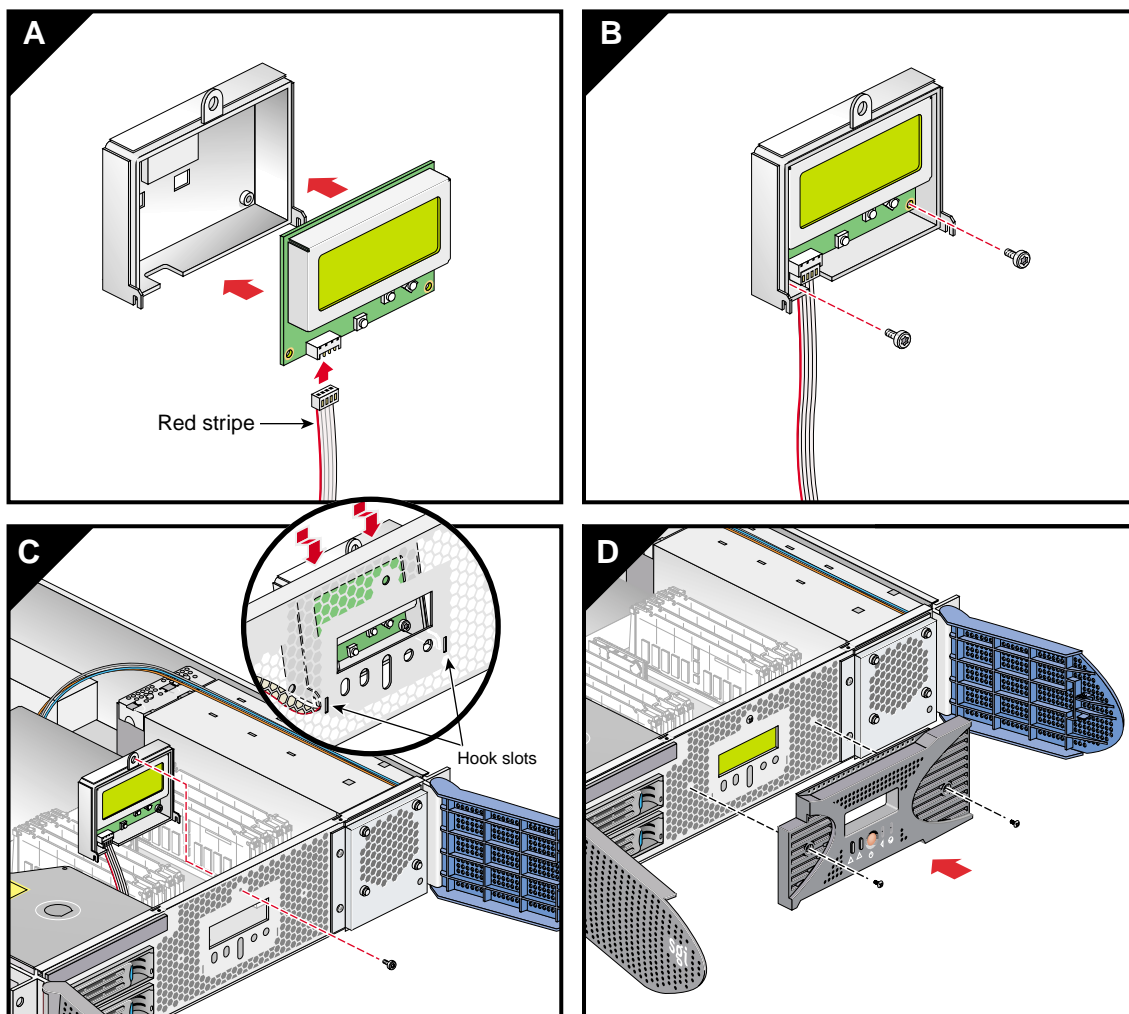
**Figure 3-23** Opening the Enclosure to Access the L1 Controller Display

6. On the front panel of your system, remove the front bezel by unscrewing the two Phillips screws holding the bezel to the chassis, as shown in Figure 3-24A.
7. Holding the L1 display cover with one hand, unscrew the single Phillips screw holding the L1 display cover to the chassis, as shown in Figure 3-24B. Gently unhook and pull away the L1 display cover from the chassis.
8. Unscrew the two Phillips screws holding the L1 controller display panel to the L1 display protective cover, as shown in Figure 3-24C.
9. Gently disconnect the L1 controller cable from the connector on the L1 controller display, as shown in Figure 3-24D.



**Figure 3-24** Removing the L1 Controller Display Panel

10. Connect the L1 controller cable to the connector on the new L1 controller display, making sure that the red stripe is to your left, as shown in Figure 3-25A.
11. Align the two screw holes on the L1 controller display with the holes on the L1 display protective cover, and screw in the two Phillips screws as shown in Figure 3-25B.



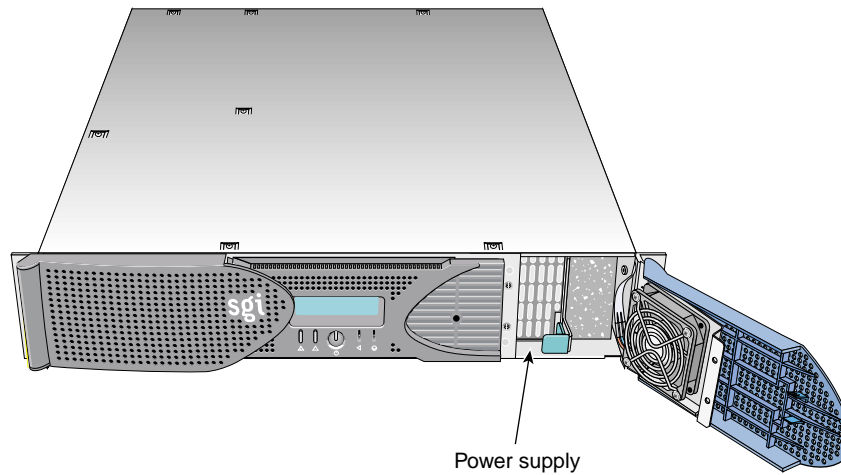
**Figure 3-25** Installing an L1 Controller Display Panel

12. Hook the L1 display protective cover onto the slots on the front chassis, and holding the L1 display cover up against the front chassis, screw in the Phillips screw as shown in Figure 3-25C.
13. Replace the front bezel onto the front of the system by screwing in the two Phillips screws that hold the bezel to the chassis (see Figure 3-25D).
14. Attach the hinged cover and secure it to the enclosure with the ten Phillips screws.
15. If your system is rackmounted, proceed to the next step. If your system is free-standing, proceed to step 18.
16. Using two people, slide the enclosure back into the rack.
17. Install the two screws that secure the enclosure to the front rails of the rack.
18. Install all of the cables at the rear of the system.
19. Power on the system. For instructions on how to power on the system, see “Using the Workstation” in Chapter 1.

## Power Supplies

Each workstation enclosure contains one power supply (see Figure 3-26). This section provides the following information:

- “Reading the Power Supply LEDs” on page 71
- “Replacing the Power Supply” on page 71



**Figure 3-26** Power Supply Location



## Reading the Power Supply LEDs

Use the LED located on the front (towards the top) of the power supply to read the condition of the power supply. Table 3-2 shows the LED status and the power supply condition the LED status indicates.

**Table 3-2** LED Status and Power Supply Condition

LED Status	Power Supply Condition Indicated
Off	This indicates that the power supply is not receiving AC power. Possible causes: the system is not plugged in correctly or a electrical fuse has blown.
Amber	This indicates a fault condition for one of the following reasons: - The voltage limit has been exceeded. - The temperature limit has been exceeded. - The current limit has been exceeded.
Blinking green	The power supply is receiving AC power, but the main primary DC power has not yet activated.
Green	The power supply is operating properly.

## Replacing the Power Supply

To replace the power supply, follow these steps:

1. Power off the system as described in the “Using the Workstation” on page 9.
2. Remove the power supply as follows:
  - a. Swing open the bezel door located on the right side of the front panel. With a Phillips screw driver, unscrew the two screws on the screen cover as shown in Figure 3-27A.
  - b. Swing open the screen cover as shown in Figure 3-27B.
  - c. Disengage the power supply from the power supply bay by pushing the interior release button to the right and pulling up and out on the green-colored handle lock, as shown in Figure 3-27C.
  - d. Gently pull out the power supply from the chassis until it clears the power supply bay, as shown in Figure 3-27D. Place the power supply on an ESD-safe surface.



**Caution:** When pulling out the power supply from the chassis, make sure not to disturb the power supply fan's ribbon cable.

---

3. Install the replacement power supply, as follows:
  - a. Position the power supply in the slot and with the power supply handle pulled up (fully opened), gently push the power supply into the bay as shown in Figure 3-28A.



**Caution:** When installing the power supply, make sure that the power supply does not clip or pinch the power supply fan's ribbon cable.

---

- b. Push in and down on the green-colored handle and snap the power supply into place as shown in Figure 3-28B.
  - c. After you have installed the power supply, swing the screen cover until it closes as shown in Figure 3-28C.



**Caution:** When closing the screen cover, make sure that the cover does not clip or pinch the power supply fan's ribbon cable.

---

- d. Screw in the two Phillips screws that you had removed as shown in Figure 3-28D, and close the bezel door.
4. Power on the system, as described in the "Using the Workstation" on page 9.

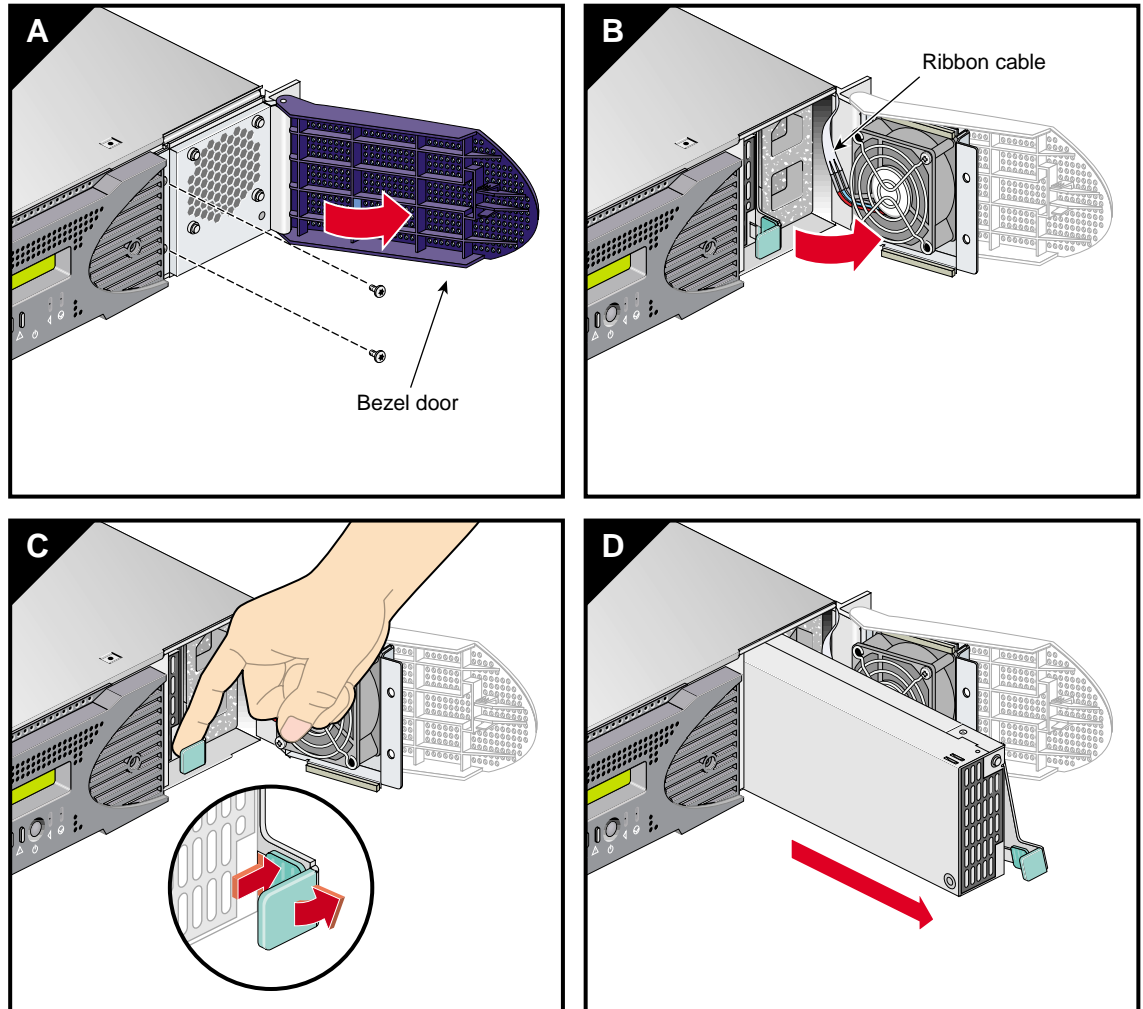
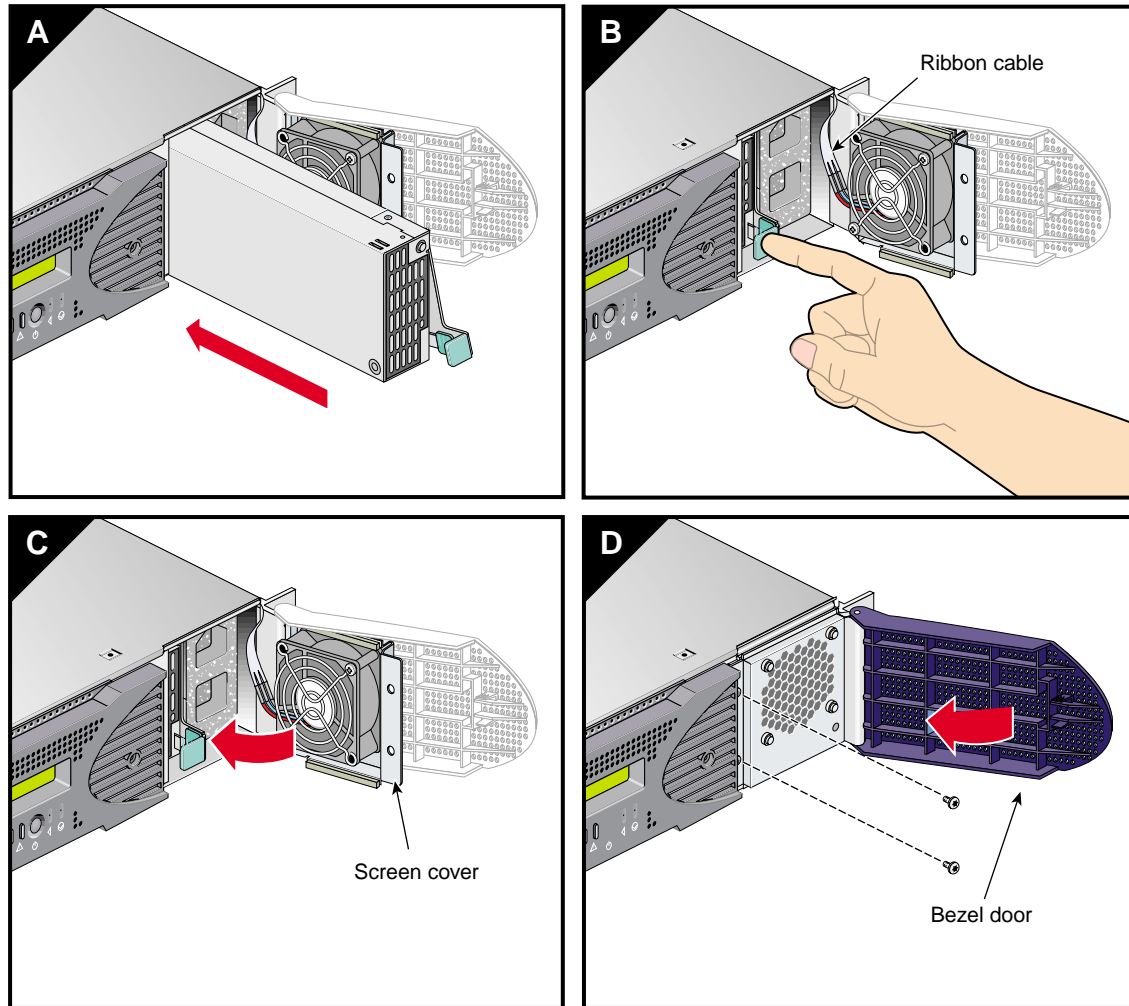


Figure 3-27 Removing the Power Supply



**Figure 3-28** Installing the Power Supply

## Troubleshooting

If you are experiencing problems with your rack-mountable Silicon Graphics® Tezro™ visual workstation, and are unable to resolve them using the information in this chapter, contact your service provider:

- If you are located in North America, contact the Technical Assistance Center at 1 800 800 4SGI. SGI personnel will guide you through the troubleshooting process.
- If you are located outside of North America, contact your local SGI subsidiary or authorized distributor.

This chapter provides the following sections to help you troubleshoot your system:

- “Troubleshooting Chart” on page 76
- “L1 Controller Error Messages” on page 77
- “SGI Electronic Support” on page 79

## Troubleshooting Chart

Table 4-1 lists recommended actions for problems that can occur on your system. For problems that are not listed in this table, use the SGI Electronic Support system (see “SGI Electronic Support” on page 79) or contact your SGI system support engineer (SSE).

**Table 4-1** Troubleshooting Chart

<b>Problem Description</b>	<b>Recommended Action</b>
The system will not power on.	<p>Ensure that the power cord of the PDU is seated properly in the power receptacle.</p> <p>Ensure that the PDU circuit breaker is on.</p> <p>Ensure that the power switch at the rear of the module is on (position 1).</p> <p>Check the power input connection on the rear of the module.</p> <p>View the L1 display; see Table 4-2 if an error message is present.</p> <p>If the L1 controller is not running, contact your SSE.</p>
The system will not boot the operating system.	Contact your SSE.
The service-required LED illuminates on either workstation enclosure.	View the L1 display of the failing enclosure; see Table 4-2 for a description of the error message.
The failure LED illuminates on either workstation enclosure.	View the L1 display of the failing module; see Table 4-2 for a description of the error message.
If the green or yellow LED of the NUMAlink port is not illuminated on a dual-enclosure workstation.	Ensure that the NUMAlink cable is seated properly on the workstation enclosures.
The PWR LED of a populated PCI slot is not illuminated.	Reseat the PCI card.
The fault LED of a populated PCI slot is illuminated (on).	Reseat the PCI card. If the fault LED remains on, replace the PCI card.
The amber LED of a disk drive is on.	Replace the disk drive.

## L1 Controller Error Messages

Table 4-2 lists error messages that the L1 controller generates and displays on the L1 display. This display is located on the front of the workstation and expansion module.

**Note:** In Table 4-2, a voltage warning occurs when a supplied level of voltage is below or above the nominal (normal) voltage by 10 percent. A voltage fault occurs when a supplied level is below or above the nominal voltage by 20 percent.

**Table 4-2** L1 Controller Messages

L1 System Controller Message	Message Meaning and Action Needed
<b>Internal voltage messages:</b>	
ATTN: x.xV high fault limit reached @ x.xxV	30-second power-off sequence for the module.
ATTN: x.xV low fault limit reached @ x.xxV	30-second power-off sequence for the module.
ATTN: x.xV high warning limit reached @ x.xxV	A higher than nominal voltage condition is detected.
ATTN: x.xV low warning limit reached @ x.xxV	A lower than nominal voltage condition is detected.
ATTN: x.xV level stabilized @ x.xV	A monitored voltage level has returned to within acceptable limits.
<b>Fan messages:</b>	
ATTN: FAN # x fault limit reached @ xx RPM	A fan has reached its maximum RPM level. The ambient temperature may be too high. Check to see if a fan has failed.
ATTN: FAN # x warning limit reached @ xx RPM	A fan has increased its RPM level. Check the ambient temperature. Check to see if the fan stabilizes.
ATTN: FAN # x stabilized @ xx RPM	An increased fan RPM level has returned to normal.

**Table 4-2** L1 Controller Messages (continued)

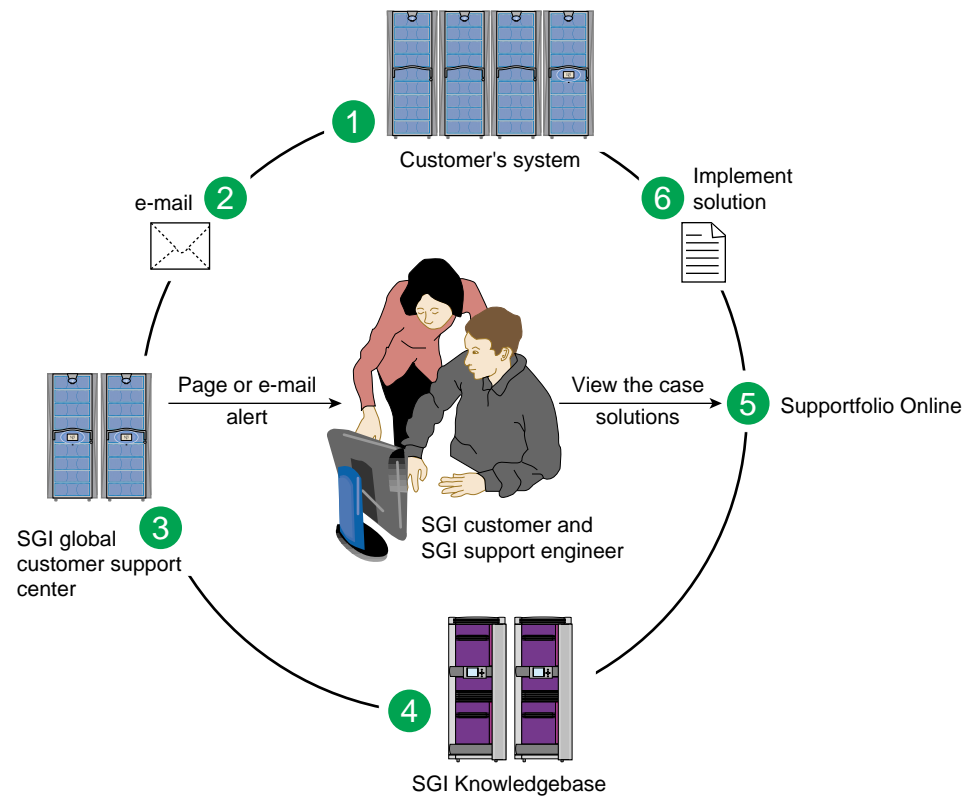
L1 System Controller Message	Message Meaning and Action Needed
<b>Temperature messages: low alt.</b>	
ATTN: TEMP # advisory temperature reached @ xxC xxF	The ambient temperature at the module's air inlet has exceeded 30 °C.
ATTN: TEMP # critical temperature reached @ xxC xxF	The ambient temperature at the module's air inlet has exceeded 35 °C.
ATTN: TEMP # fault temperature reached @ xxC xxF	The ambient temperature at the module's air inlet has exceeded 40 °C.
<b>Temperature messages: high alt.</b>	
ATTN: TEMP # advisory temperature reached @ xxC xxF	The ambient temperature at the module's air inlet has exceeded 27 °C.
ATTN: TEMP # critical temperature reached @ xxC xxF	The ambient temperature at the module's air inlet has exceeded 31 °C.
ATTN: TEMP # fault temperature reached @ xxC xxF	The ambient temperature at the module's air inlet has exceeded 35 °C.
<b>Temperature stable message:</b>	
ATTN: TEMP # stabilized @ xxC/xxF	The ambient temperature at the module's air inlet has returned to an acceptable level.
<b>Power off messages:</b>	
Auto power down in xx seconds	The L1 controller has registered a fault and is shutting down. The message displays every five seconds until shutdown.
Base module appears to have been powered down	The L1 controller has registered a fault and has shut down.



## SGI Electronic Support

SGI Electronic Support provides system support and problem-solving services that function automatically, which helps resolve problems before they can affect system availability or develop into actual failures. SGI Electronic Support integrates several services so they work together to monitor your system, notify you if a problem exists, and search for solutions to the problem.

Figure 4-1 shows the sequence of events that occurs if you use all of the SGI Electronic Support capabilities.



**Figure 4-1** Full Support Sequence

The sequence of events can be described as follows:

1. Embedded Support Partner (ESP) monitors your system 24 hours a day.
2. When a specified system event is detected, ESP notifies SGI via e-mail (plain text or encrypted).
3. Applications that are running at SGI analyze the information, determine whether a support case should be opened, and open a case if necessary. You and SGI support engineers are contacted (via pager or e-mail) with the case ID and problem description.
4. SGI Knowledgebase searches thousands of tested solutions for possible fixes to the problem. Solutions that are located in SGI Knowledgebase are attached to the service case.
5. You and the SGI support engineers can view and manage the case by using Supportfolio Online as well as search for additional solutions or schedule maintenance.
6. Implement the solution.

Most of these actions occur automatically, and you may receive solutions to problems before they affect system availability. You also may be able to return your system to service sooner if it is out of service.

In addition to the event monitoring and problem reporting, SGI Electronic Support monitors both system configuration (to help with asset management) and system availability and performance (to help with capacity planning).

The following three components compose the integrated SGI Electronic Support system:

**SGI Embedded Support Partner (ESP)** is a set of tools and utilities that are embedded in the IRIX operating system. ESP can monitor a single system or group of systems for system events, software and hardware failures, availability, performance, and configuration changes, and then perform actions based on those events. ESP can detect system conditions that indicate potential problems, and then alert appropriate personnel by pager, console messages, or e-mail (plain text or encrypted). You also can configure ESP to notify an SGI call center about problems; ESP then sends e-mail to SGI with information about the event.

**SGI Knowledgebase** is a database of solutions to problems and answers to questions that can be searched by sophisticated knowledge management tools. You can log on to SGI Knowledgebase at any time to describe a problem or ask a question. Knowledgebase searches thousands of possible causes, problem descriptions, fixes, and how-to instructions for the solutions that best match your description or question.

**Supportfolio Online** is a customer support resource that includes the latest information about patch sets, bug reports, and software releases.

The complete SGI Electronic Support services are available to customers who have a valid SGI Warranty, FullCare, FullExpress, or Mission-Critical support contract. To purchase a support contract that allows you to use the complete SGI Electronic Support services, contact your SGI sales representative. For more information about the various support contracts, see the following website:

<http://www.sgi.com/support/customerservice.html>

For more information about SGI Electronic Support, see the following website:

<http://www.sgi.com/support/es>



## Technical Specifications and Pinouts

This chapter contains technical information about the rack-mountable Silicon Graphics® Tezro™ visual workstation. The following topics are covered:

- “Physical and Environmental Specifications” on page 84
- “Power Supply Specifications” on page 85
- “I/O Connector Specifications” on page 86
- “VPro™ Graphics Board I/O Port Specifications” on page 95
- “Rack Specifications” on page 101

## Physical and Environmental Specifications

Table A-1 shows the physical and environmental specifications for the workstation enclosure.

**Table A-1** Physical and Environmental Specifications

Feature	Specification
Dimensions	Height: 8.8 cm (3.44 in.) Width: 43.36 cm (17.06 in.) Depth: 67.05 cm (26.4 in.) (including bezel)
Weight	Minimum: 17.9 kg (39.5 lb) Maximum: 19.3 kg (42.5 lb)
Power requirements	50-60 Hz and 100-120/200-240 VAC
Voltage and frequency	100-240 VAC, 50-60 Hz, 7-3 A, 430 W
Temperature tolerance (operating)	+5 °C (41 °F) to +45 °C (113 °F) 1500 m (5000 ft) ASL or less +5 °C (41 °F) to +35 °C (95 °F) 1500 m (5000 ft) ASL to 3000 m (10,000 ft) ASL
Temperature tolerance (non-operating)	-40 °C (-40 °F) to +60 °C (140 °F)
Relative humidity	10% to 95% RH, non-condensing
Heat dissipation	1900 Btu/hr maximum
Maximum altitude	Sea level to 3,000 m (10,000 ft.)operating Sea level to 12,200 m (40,000 ft.)non-operating
Vibration, sine sweep (operating)	0.25 G, 5-500 Hz
Vibration, sine sweep (non-operating)	0.5 G, 3-200 Hz
Vibration, random (operating)	0.10 Grms for 15 minutes
Vibration, random (non- operating)	1.15 Grms for 15 minutes

**Table A-1** Physical and Environmental Specifications **(continued)**

<b>Feature</b>	<b>Specification</b>
Shock, half-sine wave (operating)	30 G, 3 msec (vertical); 15 G, 3 msec. (horizontal)
Shock, trapezoidal wave (non-operating)	30 G, 200 in./sec.
Sound power	5.6 bels up to +25 °C (77 °F)

## Power Supply Specifications

Table A-2 shows the power supply specification for the rack-mountable workstation

**Table A-2** Power Supply Specification

<b>Feature</b>	<b>Specification</b>
Input voltage rating	120/240 VAC auto-sensing (~563W)

## I/O Connector Specifications

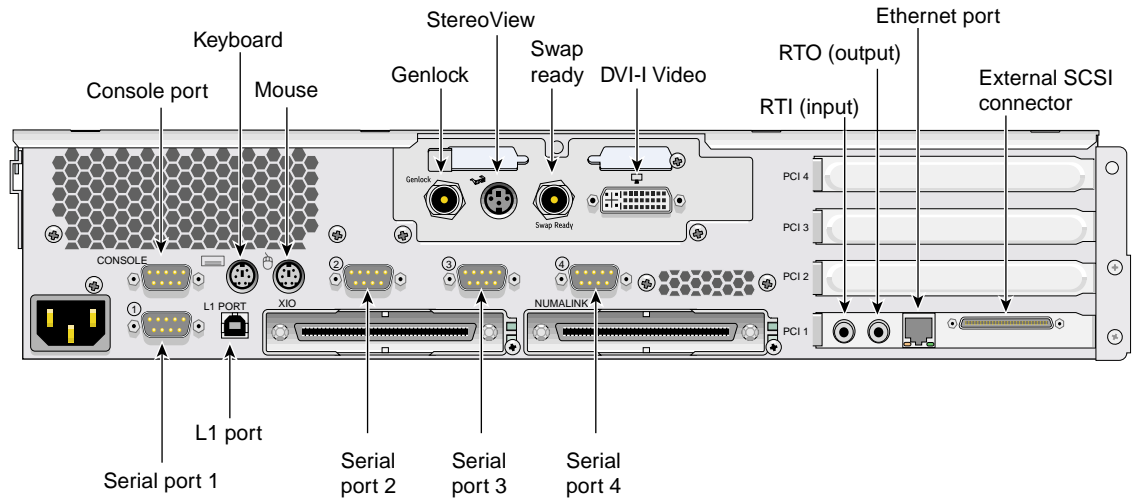
Table A-3 and Figure A-1 list the non-proprietary connectors that are located on the rear panel of the workstation. This section discusses these ports.

**Table A-3** Workstation Connectors

Port	Connector	Pin Assignments
Ethernet port (IO9 only)	RJ-45	See Figure A-2 on page 87
Keyboard and mouse ports	9-pin mini-DIN	See Figure A-3 on page 88 and Table A-5 on page 89
Serial ports 1 through 4 <sup>a</sup>	DB9	See Figure A-4 on page 90
L1 console port	DB9	See Figure A-4 on page 90
External SCSI port (with IO9 only)	SCSI 68-pin VHDCI	See Figure A-5 on page 91 and Table A-7 on page 91
RT interrupt input and output ports (IO9 only)	Stereo jack	See Figure A-6 on page 93 and Table A-8 on page 93
USB-A port on optional USB card	USB-A	See Figure A-7 on page 94 and Table A-9 on page 94

a. Serial ports 2, 3, and 4 and the keyboard and mouse reside on a daughtercard. This daughtercard is only present in the first enclosure of the workstation.

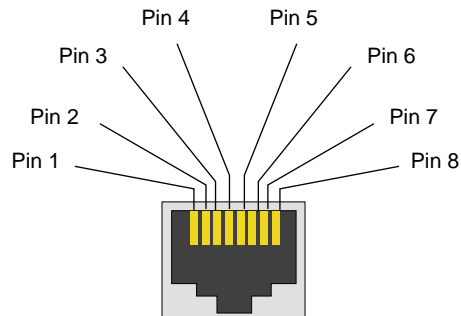




**Figure A-1** Rear Panel Connectors

## Ethernet 10/100/1000BaseT Port

The Ethernet port is located on the IO9 board. The workstation auto-selects the Ethernet port speed and type (duplex vs. half-duplex) when the workstation is booted, based on what it is connected to. Figure A-2 shows the Ethernet port.



**Figure A-2** Ethernet 10/100/1000BaseT Port Pinout

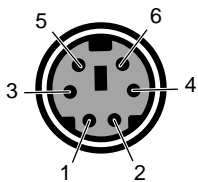
Table A-4 shows the cable pinout assignments for the Ethernet port.

**Table A-4** Ethernet Connector Pin Assignments

10/100BaseT Ethernet Pinouts		1000BaseT Ethernet Pinouts	
Pin	Assignment	Pin	Assignment
1	Transmit +	1	Transmit/Receive 0+
2	Transmit –	2	Transmit/Receive 0–
3	Receive +	3	Transmit/Receive 1+
4	Not used	4	Transmit/Receive 2+
5	Not used	5	Transmit/Receive 2–
6	Receive –	6	Transmit/Receive 1–
7	Not used	7	Transmit/Receive 3+
8	Not used	8	Transmit/Receive 3–

## Keyboard and Mouse Connectors

The workstation uses keyboards and mice that are PS/2-compatible. The combined current draw of the keyboard and mouse is limited to 0.5 A at +5 V. Figure A-3 shows an example of the 6-pin mini-DIN connectors to which the keyboard and mouse connect.



**Figure A-3** PS/2 Keyboard and Mouse Port Pinout

Table A-5 shows the pinout assignment for the keyboard and mouse ports.

**Table A-5** Keyboard and Mouse Port Pinout

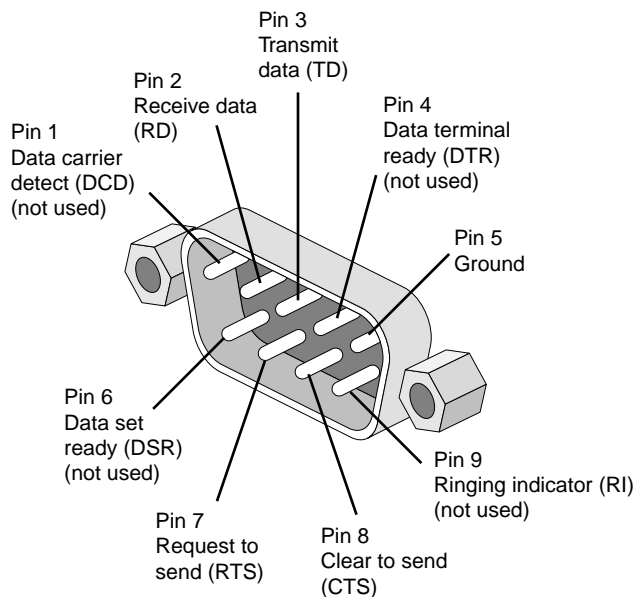
<b>Pin</b>	<b>Assignment</b>
1	Keyboard/mouse data
2	(Reserved)
3	Ground
4	Keyboard/mouse power (+5 V)
5	Keyboard/mouse clock
6	(Reserved)

## Serial Ports

The workstation features four 9-pin serial ports. These ports are capable of transferring data at rates as high as 230 kbps. Other features of the ports include the following:

- Programmable data, parity, and stop bits
- Programmable baud rate and modem control

Figure A-4 shows a serial port.



**Figure A-4** Serial Port Pinouts and Locations

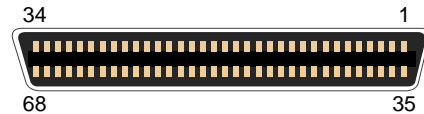
Table A-6 shows pinout assignments for the 9-pin male DB-9 connector.

**Table A-6** Serial Port Pinout

Pin	Assignment	Description
1	DCD	Data carrier detect
2	RXD	Receive data
3	TXD	Transmit data
4	DTR	Data terminal ready
5	GND	Signal ground
6	DSR	Data set ready
7	RTS	Request to send
8	CTS	Clear to send
9	RI	Ring indicator

## External SCSI Port Connector

Figure A-5 shows the external SCSI VHDCI connector pin locations for the external SCSI connector. This connector is used on the IO9 PCI card. Table A-7 lists the pin assignments for this SCSI connector.



**Figure A-5** External SCSI Port Pin Number Locations

**Table A-7** SCSI VHDCI Pin Assignments

Pin Number	Signal Name	Pin Number	Signal Name
1	+DB (12)	35	-DB (12)
2	+DB (13)	36	-DB (13)
3	+DB (14)	37	-DB (14)

**Table A-7** SCSI VHDCI Pin Assignments (**continued**)

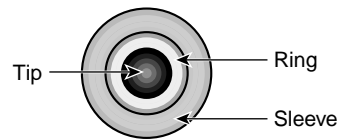
Pin Number	Signal Name	Pin Number	Signal Name
4	+DB (15)	38	-DB (15)
5	+DB (P1)	39	-DB (P1)
6	+DB (0)	40	-DB (0)
7	+DB (1)	41	-DB (1)
8	+DB (2)	42	-DB (2)
9	+DB (3)	43	-DB (3)
10	+DB (4)	44	-DB (4)
11	+DB (5)	45	-DB (5)
12	+DB (6)	46	-DB (6)
13	+DB (7)	47	-DB (7)
14	+DB (P0)	48	-DB (P0)
15	Ground	49	Ground
16	DIFFSENS	50	Ground
17	TERMPWR	51	TERMPWR
18	TERMPWR	52	TERMPWR
19	Reserved	53	Reserved
20	Ground	54	Ground
21	+ATN	55	-ATN
22	Ground	56	Ground
23	+BSY	57	-BSY
24	+ACK	58	-ACK
25	+RST	59	-RST
26	+MSG	60	-MSG
27	+SEL	61	-SEL

**Table A-7** SCSI VHDCI Pin Assignments **(continued)**

Pin Number	Signal Name	Pin Number	Signal Name
28	+CD	62	-CD
29	+REQ	63	-REQ
30	+IO	64	-IO
31	+DB (8)	65	-DB (8)
32	+DB (9)	66	-DB (9)
33	+DB (10)	67	-DB(10)
34	+DB (11)	68	-DB (11)

## Stereo Jack Connector Conductor

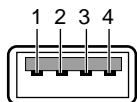
Figure A-6 shows the stereo jack connector conductors that are used for the RT interrupt input and RT interrupt output ports of the IO9 PCI card. Table A-8 lists the conductor assignments for the stereo jack connector.

**Figure A-6** Stereo Jack Connector Conductors**Table A-8** Stereo Jack Connector Conductor Assignments

Conductor	Function
Tip	+5 V
Ring	Interrupt (active low)
Sleeve	Chassis ground and cable shield

## USB Type A Connector

Figure A-7 shows the USB type A connector that is used on the optional USB PCI card. Table A-9 lists the pin assignments.



**Figure A-7** USB Type A Connector Pin Number Locations

**Table A-9** USB Type A Connector Pin Assignments

Signal	Color	Pin Number
VCC	Red	1
-Data	White	2
+Data	Green	3
Ground	Black	4



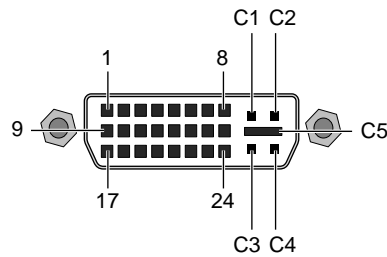
## VPro™ Graphics Board I/O Port Specifications

This section provides specifications for the following ports:

- “DVI-I Video Port” on page 95
- “Stereo View Port” on page 98
- “Genlock Port” on page 99
- “Swap Ready Port” on page 100

### DVI-I Video Port

Figure A-8 shows the DVI-I video port.



**Figure A-8** DVI-I Port Pinout and Location

Table A-10 shows the port pinout assignments for DVI-I port(s).

**Table A-10** DVI-I Video Port Pinout

<b>Pin</b>	<b>Assignment</b>	<b>Pin</b>	<b>Assignment</b>
1	DATA 2-	16	HOT_POWER
2	DATA2+	17	DATA 0-
3	SHIELD 2/4	18	DATA 0+
4	DATA 4-	19	SHIELD 0/5
5	DATA 4+	20	DATA 5-
6	DDC_CLOCK	21	DATA 5+
7	DDC_DATA	22	SHIELD CLOCK
8	VSYNC	23	CLOCK -
9	DATA 1-	24	CLOCK +
10	DATA1+	C1	A_RED
11	SHIELD 1/3	C2	A_GREEN
12	DATA 3-	C3	A_BLUE
13	DATA 3+	C4	HYNSC
14	DDC_POWER	C5	A_GROUND2
15	A_GROUND1	C6	A_GROUND3

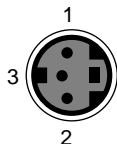
Table A-11 lists the resolutions and frequencies supported by the graphics board.

**Table A-11** Supported VPro Graphics Board Scan Rates

<b>Resolution</b>	<b>Refresh Rate</b>
1024x768	60 Hz, 75 Hz, and 96 Hz-stereo
1280x1024	59, 60, 72, 75, 85 Hz, and 96 Hz-stereo
1280x1024	100 Hz Stereo (also through DCD-2)
1280x720	60 and 72 Hz
1280x1024	30 Hz interlaced
1280x960	30 Hz interlaced
1600x1024	83 Hz
1600x1200	60, 72, and 75 Hz
1920x1035	30 Hz interlaced
1920x1080	30 Hz interlaced
1920x1200	60 Hz
1920x1200	25 and 30 Hz

## Stereo View Port

The following diagram shows the Stereo View port.



**Figure A-9** Stereo View Port Pinout

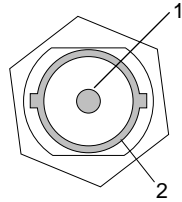
Table A-12 shows the cable pinout assignments for the Stereo View port on the graphics board.

**Table A-12** Stereo View Pinout Assignments

Pin	Assignment
1	+12 VDC output to Stereo View device
2	Ground
3	Stereo left/right Eye signal (1=left, 0=right) (STEREO_LEFT)

## Genlock Port

The following diagram shows the Genlock port.



**Figure A-10** Genlock Port Pinout

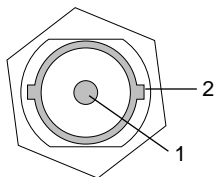
Table A-13 shows the cable pinout assignments for the Genlock port on the graphics board.

**Table A-13** Genlock Pinout Assignments

Pin	Assignment
1	Genlock input/output video or 3.3-V TTL signal levels
2	Signal - return ground

## Swap Ready Port

The following diagram shows the Swap Ready port.



**Figure A-11** Swap Ready Port Pinout

Table A-14 shows the cable pinout assignments for the Swap ready port on the graphics board.

**Table A-14** Swap Ready Pinout Assignments

Pin	Assignment
1	Swapbuffer gang sync open Collector I/O
2	Signal return ground

## Rack Specifications

The workstation can be mounted in any industry-standard 19-in. rack. The following specification are for short (17U) and tall (39U) SGI racks.

---

**Note:** One U is 1.75 in. (4.45 cm).

---

Table A-15 lists the specifications of the short rack.

**Table A-15** Short Rack Specifications

Characteristic	Specification
Height	36.06 in. (916 mm)
Width	25.38 in. (645 mm)
Depth	40.63 in. (1032 mm)
Weight (maximum)	488 lb (221 kg)
Shipping weight (maximum)	563 lb (255 kg)

Table A-16 lists the specifications of the tall rack.

**Table A-16** Tall-rack Specifications

Characteristic	Specification
Height	75.82 in. (1925.83 mm)
Width	23.62 in. (599.95 mm)
Depth	41.25 in. (1048 mm)
Weight (maximum)	1,100 lb (499 kg)
Shipping weight (maximum)	1,281 lb (581 kg)





---

## Rackmounting Rail Installation Instructions

This appendix provides instructions for installing your rack-mountable Silicon Graphics® Tezro™ visual workstation in a rack in the following sections:

- “Space Requirements” on page 103
- “Rackmounting Hardware” on page 104
- “Preparing the Slide Rail Assemblies” on page 105
- “Preparing the Module” on page 108
- “Determining Where to Attach the Slide Rail in the Rack” on page 109
- “Attaching the Slide Rail to the Rack” on page 110
- “Installing Clip Nuts in Rack Rails” on page 113
- “Installing Modules in the Rack” on page 114
- “Adjusting the Position of the Rackmounted Module” on page 116

### Space Requirements

Table B-1 specifies the space requirements for the workstation when it is installed in a 19-inch rack.

**Table B-1** Space Requirements

<b>Feature</b>	<b>Specification</b>
Height	3.46 in. (8.79 cm)
Width	19.0 in. (48.3 cm)
Depth	27.0 in. (68.6 cm)
Required front clearance for module	8.25 in. (20.96 cm)

**Table B-1** Space Requirements **(continued)**

Feature	Specification
Required rear clearance for module	10.00 in. (25.40 cm)
Required front clearance for rack	36 in. (91 cm)
Required rear clearance for rack	36 in. (91 cm)

---

**Note:** The measurements listed in Table B-1 are for a single-enclosure workstation.

---

## Rackmounting Hardware

Table B-2 lists the hardware that you will need to mount the module in a 19-in. rack.

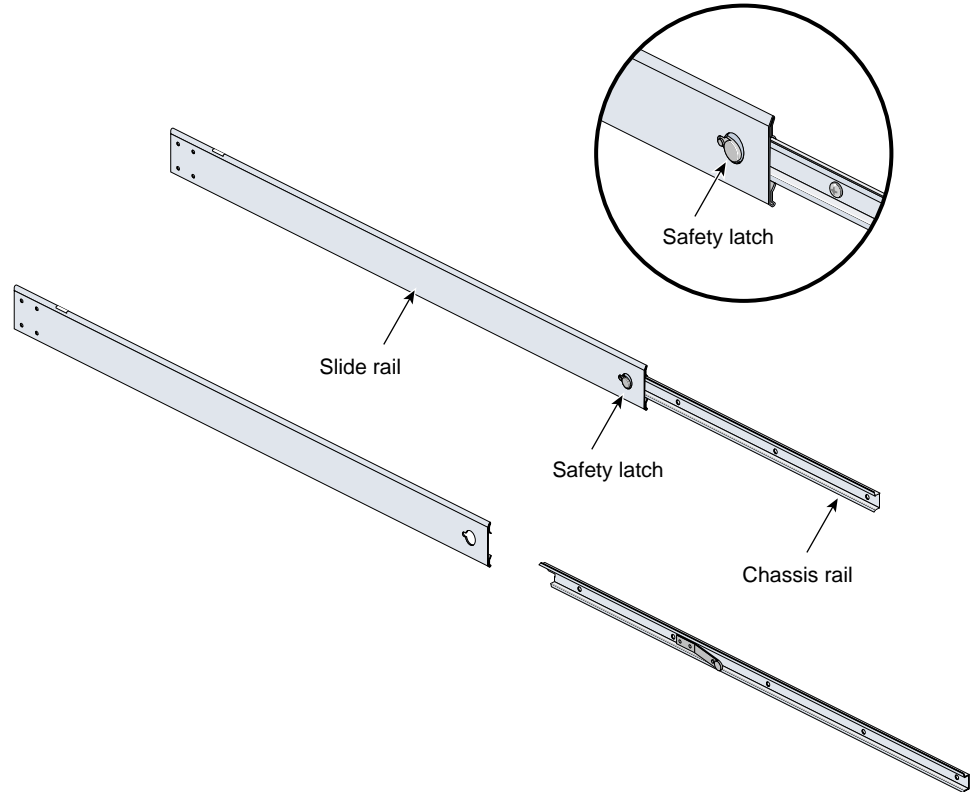
**Table B-2** Rackmounting Hardware

Hardware Type	Quantity (per enclosure)	Usage
Slide rail assembly (includes chassis rail)	2	Allows the enclosure to slide in and out of rack. (The left and right slides are identical.)
2-in. rear mounting bracket	2	Mounts the slide rails to the rear rack rails. (The left and right brackets are identical.)
10-24 x 1/4-in. Phillips screw	10	Secures the chassis rails to the module.
10-32 x 1/2-in. Phillips screw	8	Secures the slide rails to the rack rails.
Shoulder washer	8	
Bar nut	4	
10-32 x 1/2-in. Phillips screw	4	Secures the slide rails to their mounting brackets.
Bar nut	2	
10-32 clip nut	2	Provides a threaded hole for fastening the module front panel to the rack rails.
10-32 x 1/2-in. Phillips screw	2	Fastens the module front panel to the clip nut.

## Preparing the Slide Rail Assemblies

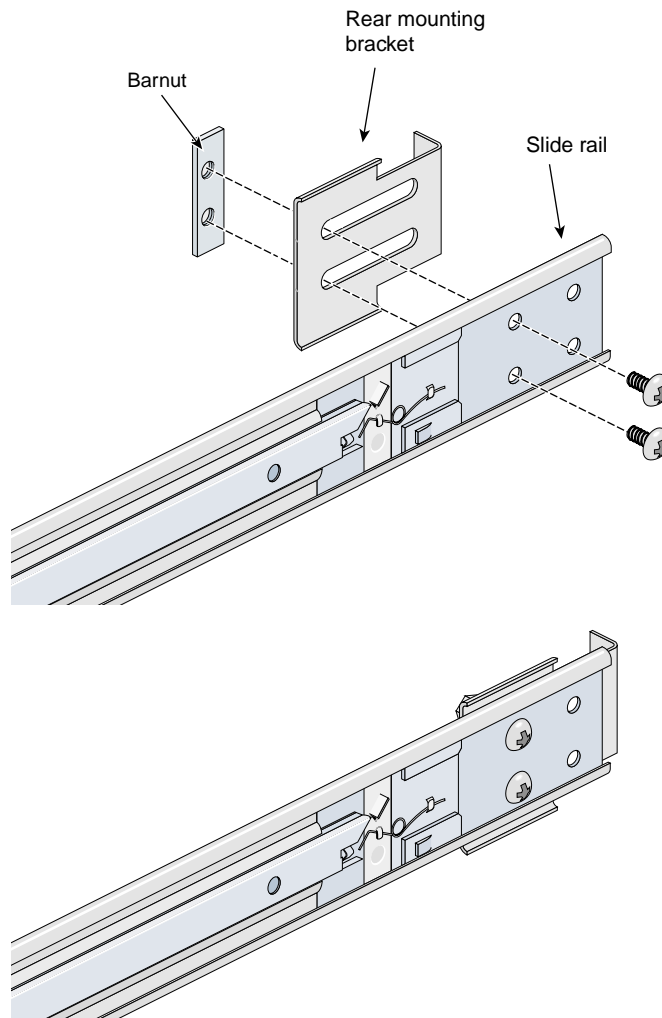
The slide rail assembly consists of a chassis rail and a slide rail. You need to separate the chassis rail from the slide rail so that you can install a mounting bracket to the slide rail and attach the chassis rail to the module chassis (see “Preparing the Module” on page 108). To separate the chassis rail from the slide rail, follow these steps:

1. Remove the two slide rail assemblies and the rear mounting brackets from the shipping container.
2. Extend each slide rail assembly until the safety latch snaps into place.
3. Press the safety latch and remove the chassis rail from the slide rail, as shown in Figure B-1.



**Figure B-1** Separating the Chassis Rail from the Slide Rail

4. Place one of the mounting brackets on the back of the slide rail, as shown in Figure B-2. Adjust the position of the mounting bracket on the slide rail according to the depth of the rack.
5. Place a bar nut behind the mounting bracket. Secure the mounting bracket to the slide rail by inserting two 10-32 x 1/2-in. screws through the slide rail mounting bracket into the bar nut, as shown in Figure B-2.
6. Repeat steps 4 and 5 to attach a mounting bracket to the other slide rail.



**Figure B-2** Attaching the Rear Mounting Bracket to the Slide Rail

## Preparing the Module

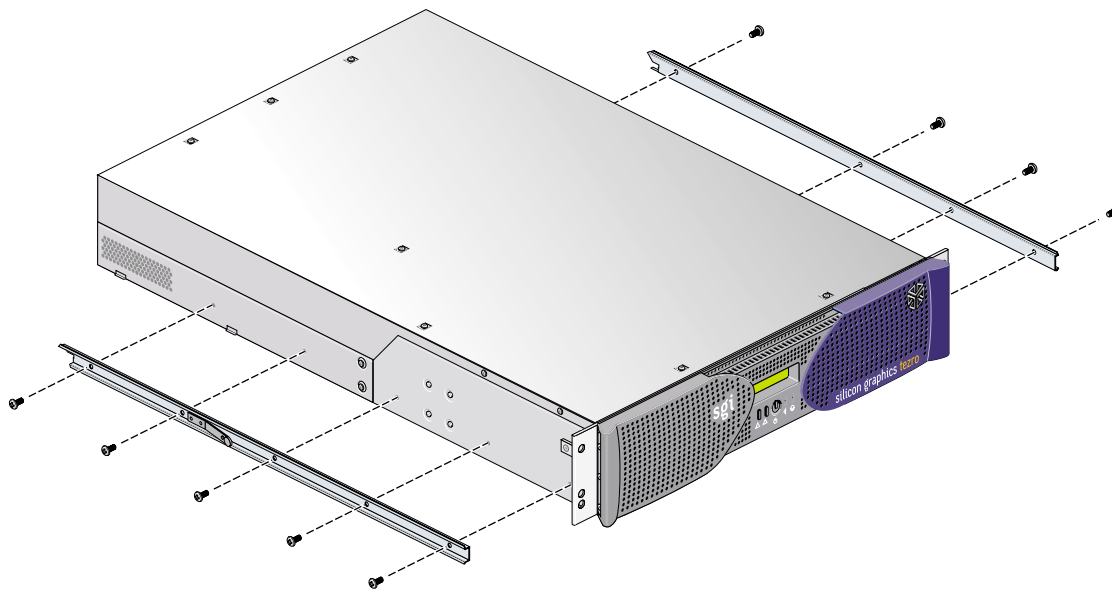
To attach the chassis rails to the module, follow these steps:

1. Place the module on a flat, stable surface.
2. Using five 10-24 x 1/4-in. screws, attach one of the chassis rails to the right side of the module chassis. Ensure that the rail is installed in the correct direction (see Figure B-3).



**Caution:** Use only the 1/4-in. (0.64 cm) length screws. Longer screws damage internal components of the chassis.

3. Repeat Step 2 to mount the second rail to the left side of the module chassis.

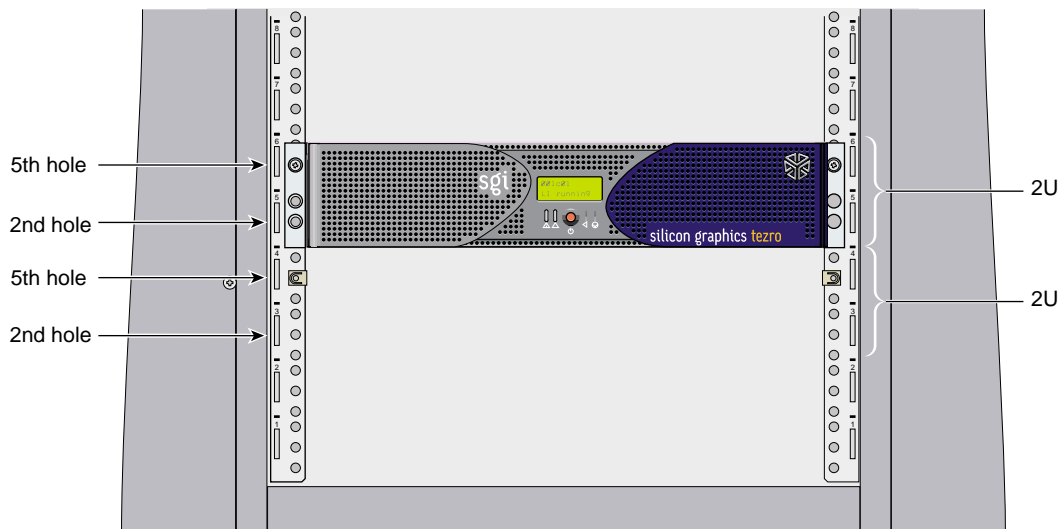


**Figure B-3** Attaching Chassis Rails to the Module Chassis

## Determining Where to Attach the Slide Rail in the Rack

The module requires two units (U) of space within the rack. (One unit is equivalent to 1.75 in. [44.5 cm].) To determine where you should install the slide rails in the rack, you must count mounting holes. Each U contains three mounting holes; therefore, in the 2U of space that the module occupies, there are six mounting holes. The bottom hole of the 2U space is hole 1. The top mounting hole in the 2U space is hole 6. See Figure B-4.

**Note:** Modules in the rack are identified by the lowest U number they occupy. For example, in Figure B-4 the module resides in U4 (the fourth unit within the rack).



**Figure B-4** Mounting Hole Pattern of Rack Vertical Rails

To determine how many mounting holes you must count, use the following formula:  $3 \times (\text{the lowest U number that the module will occupy}) - 2$ . For example, when you want to install the module in locations U9 and U10, count 25 mounting holes ( $3 \times 9 - 2$ ) starting from the bottom of the rack. The 25th hole is the first mounting hole of U9.

## Attaching the Slide Rail to the Rack

To attach the slide rail to the rack, follow these steps:

---

**Tip:** The slide rails must be level in the rack. To ensure that you install the slide rails correctly, carefully count the mounting holes on all of the rack rails (two front rails and two rear rails).

---

1. Locate eight 10-32 x 1/2-in. Phillips screws, eight shoulder washers, and four bar nuts.
2. Place one of the bar nuts inside the rack and align it with the second and third holes of the selected 2U of space (see Figure B-5).

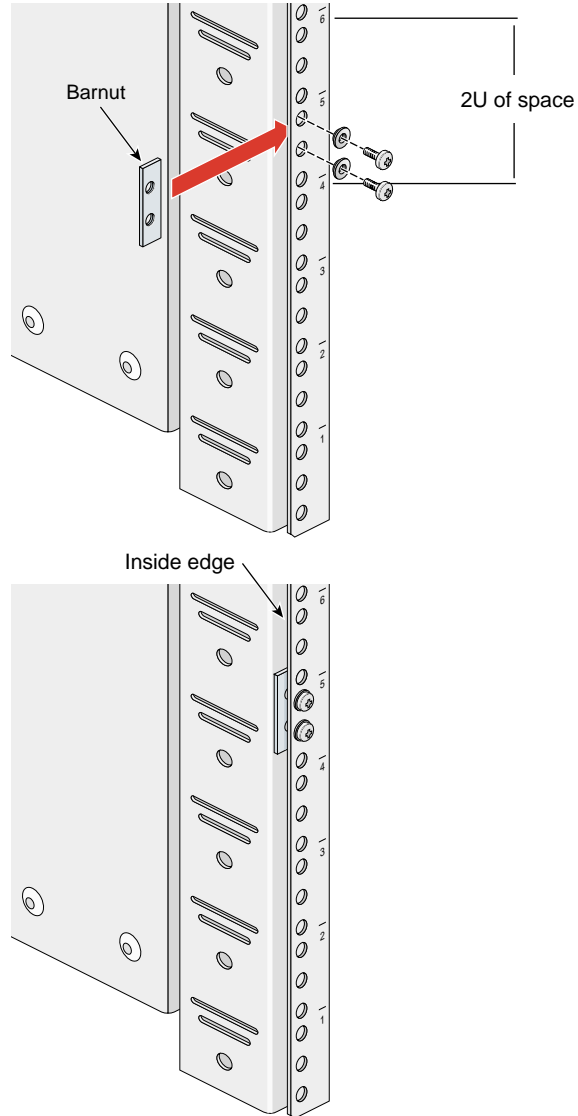
---

**Note:** The holes in the bar nuts are not centered. The bar nuts need to be oriented so that the holes are closest to the inside edge of the rack rails. See Figure B-5.

---

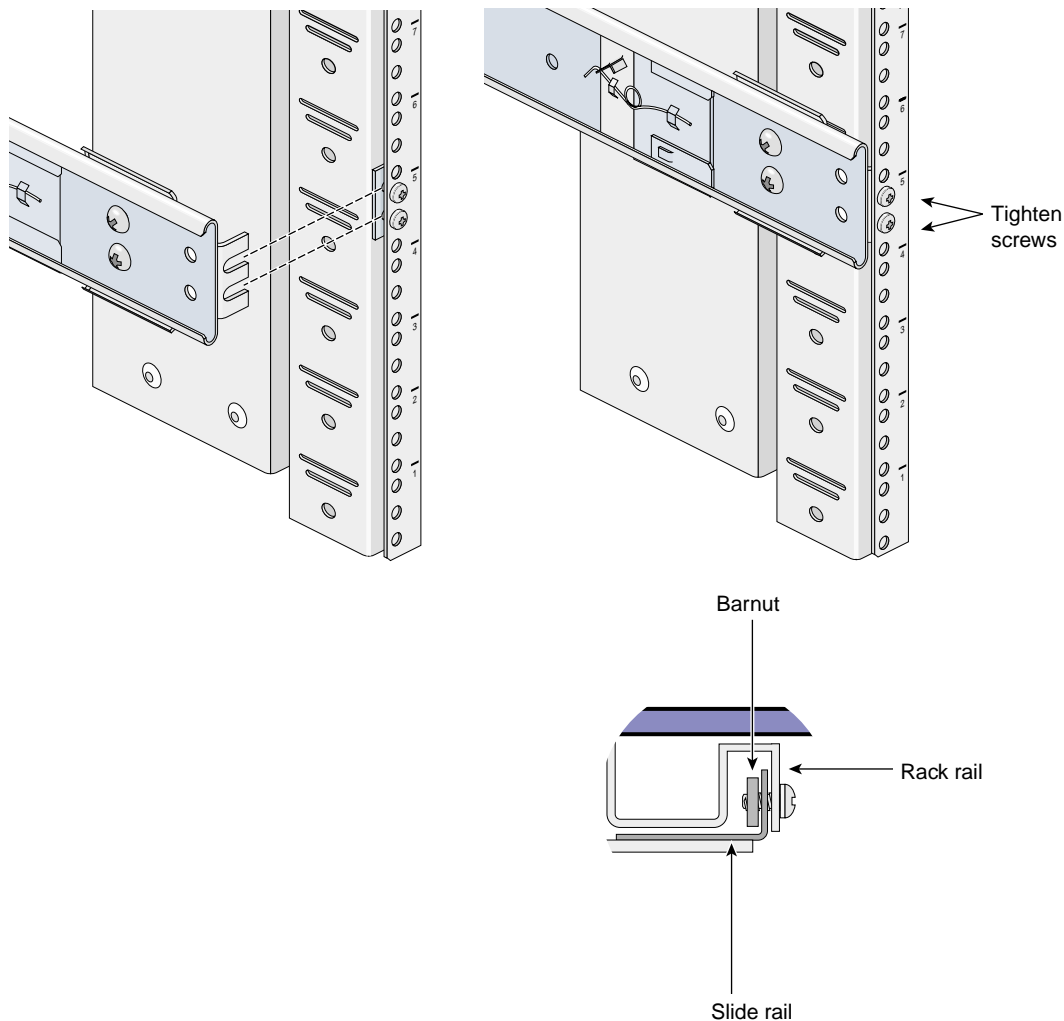
3. Insert two screws with shoulder washers through the rack rail to hold the bar nut in place. Do not be tighten the screws at this time.
4. Repeat Steps 2 and 3 to install the remaining three bar nuts on the other three rack rails (front and rear of rack).





**Figure B-5** Placing the Bar Nuts on the Rack Rails

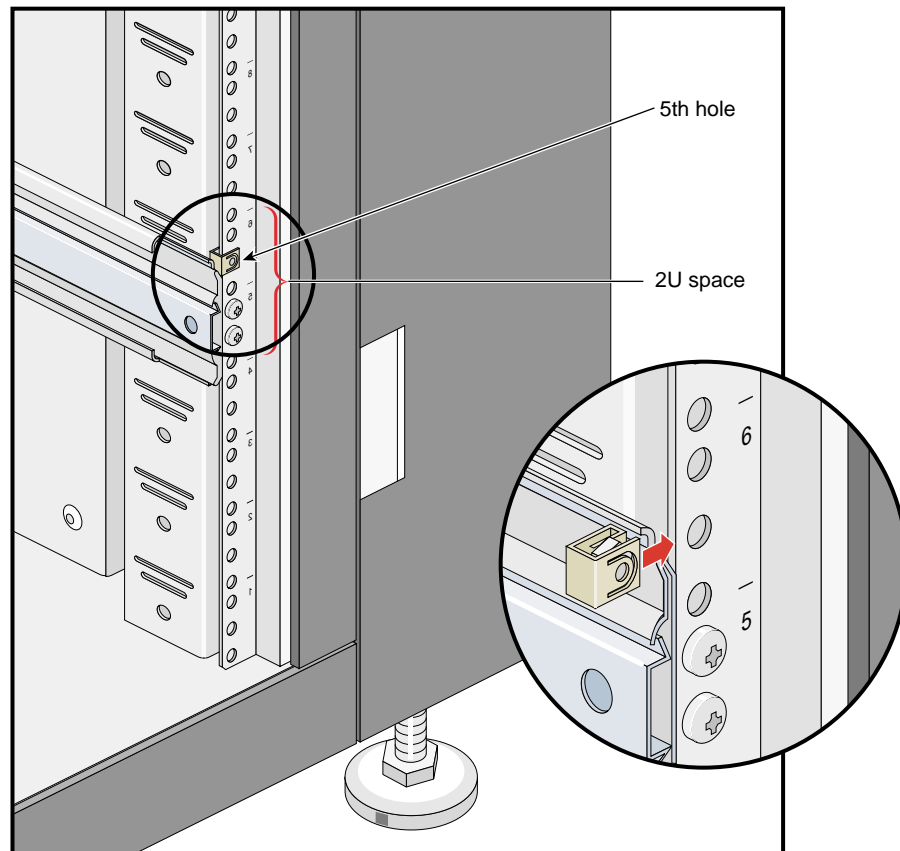
5. Insert the front and rear brackets of one of the slide rails between the rack rails and the bar nuts, as shown in Figure B-6.
6. Tighten the screws on the front- and rear-ends of the rails. Do not tighten firmly at this time, because all screws will be firmly tightened once the module is installed in the rack.
7. Repeat steps 5 and 6 to attach the second slide rail to the other side of the rack.



**Figure B-6** Attaching the Slide Rail to the Rack

## Installing Clip Nuts in Rack Rails

Clip nuts secure the modules to the rack. To install the clip nuts, slide the clip nuts over the fifth hole of the selected 2U of space on each of the front rails. See Figure B-7 for details.



**Figure B-7** Installing Clip Nuts in Rack Rails

## Installing Modules in the Rack

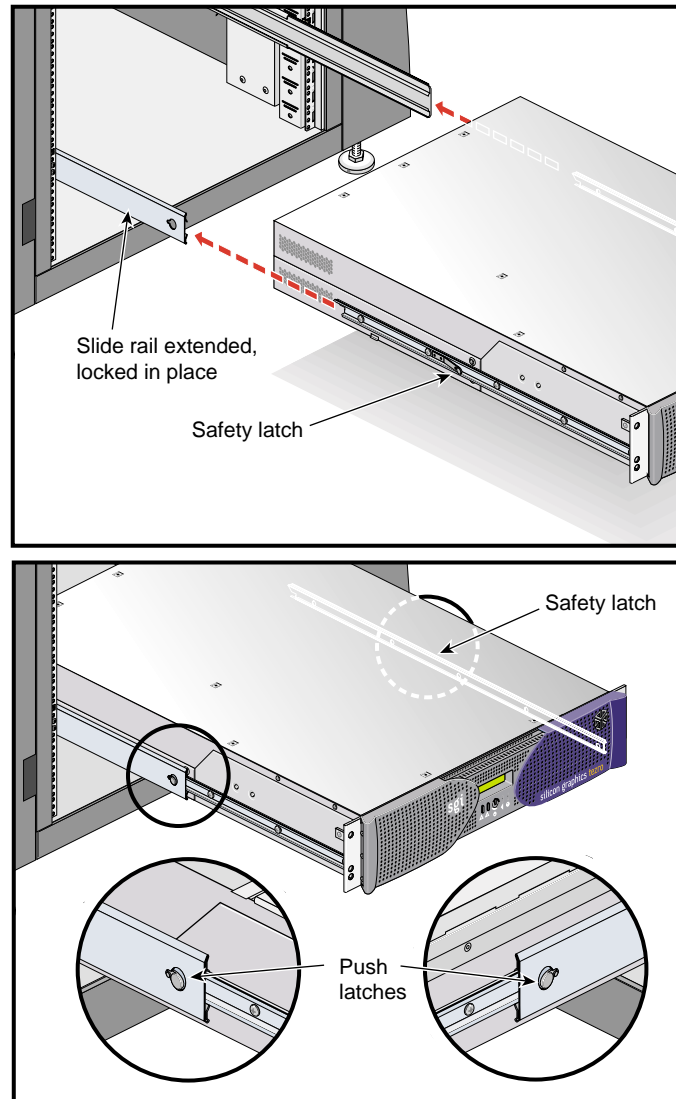
To install a module in the rack, follow these steps:

---

**Note:** Step 2 requires two people.

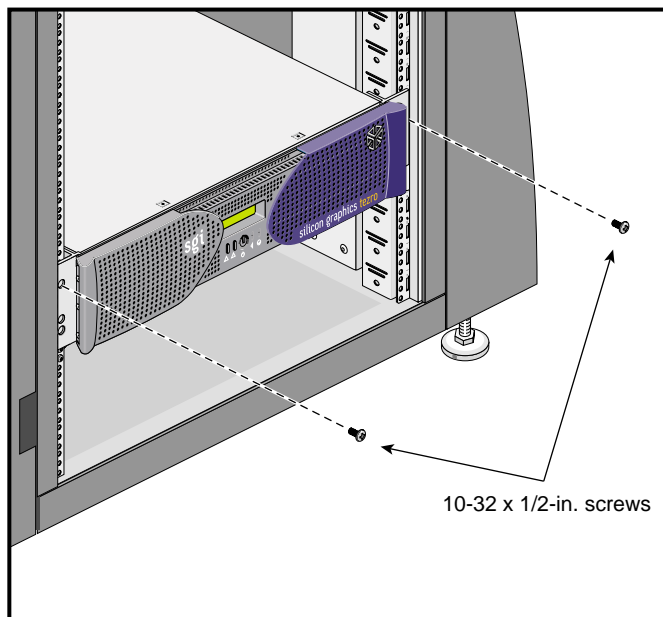
---

1. Fully extend the left and right slide rails from the rack until they lock into place.
2. With one person holding each side of the module, align the chassis rails of the module with the slide rails of the rack.
3. Slide the chassis rails into the slide rails until the chassis rails are stopped by the safety latches.
4. Press the safety latches on both sides of the module to fully seat the chassis rails into the slide rails (see Figure B-8).
5. Firmly tighten all screws (the eight screws that secure the slide rails to the rack rails).



**Figure B-8** Pressing the Safety Latches

- Secure the module to the rack by inserting a 10-32 x 1/2-in. Phillips screw in the top hole of each chassis ear (see Figure B-9).



**Figure B-9** Securing the Module to the Rack

## Adjusting the Position of the Rackmounted Module

Once the module is installed in the rack, you can make minor adjustments to its position in the rack (upward and side-to-side). To adjust the position of the module, loosen the front mounting screws, adjust the module to the desired position, and then tighten the mounting screws.



---

**Caution:** Do not lift the module by its bezel; it is not designed to handle the weight of the module. Instead, use the chassis ears to move the module (see Figure B-10).

---

## Removing a Module from a Rack

To remove a module from the rack, follow these steps:

1. Power off the module. For instructions on how to power off the module, see “Powering Off the Workstation” on page 13.
2. Disconnect all of the cables at the rear of the module.

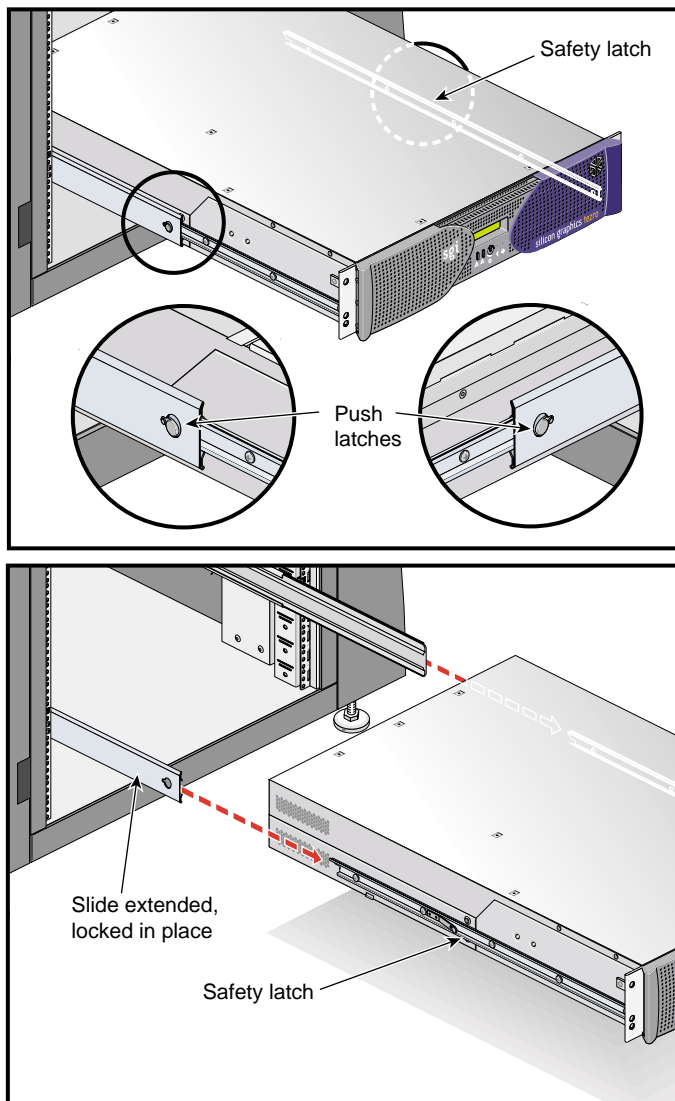


---

**Warning:** Components may be hot. To avoid injury, allow the components to cool for approximately five minutes before you proceed with these instructions.

---

3. Remove the two screws that secure the system to the front rails of the rack.
4. Carefully pull the module out of the rack until it is stopped by the safety latches.
5. With one person holding each side, release the safety latches on both sides of the module and pull it out of the slide rails (see Figure B-10).
6. Place the module on a flat, stable surface.

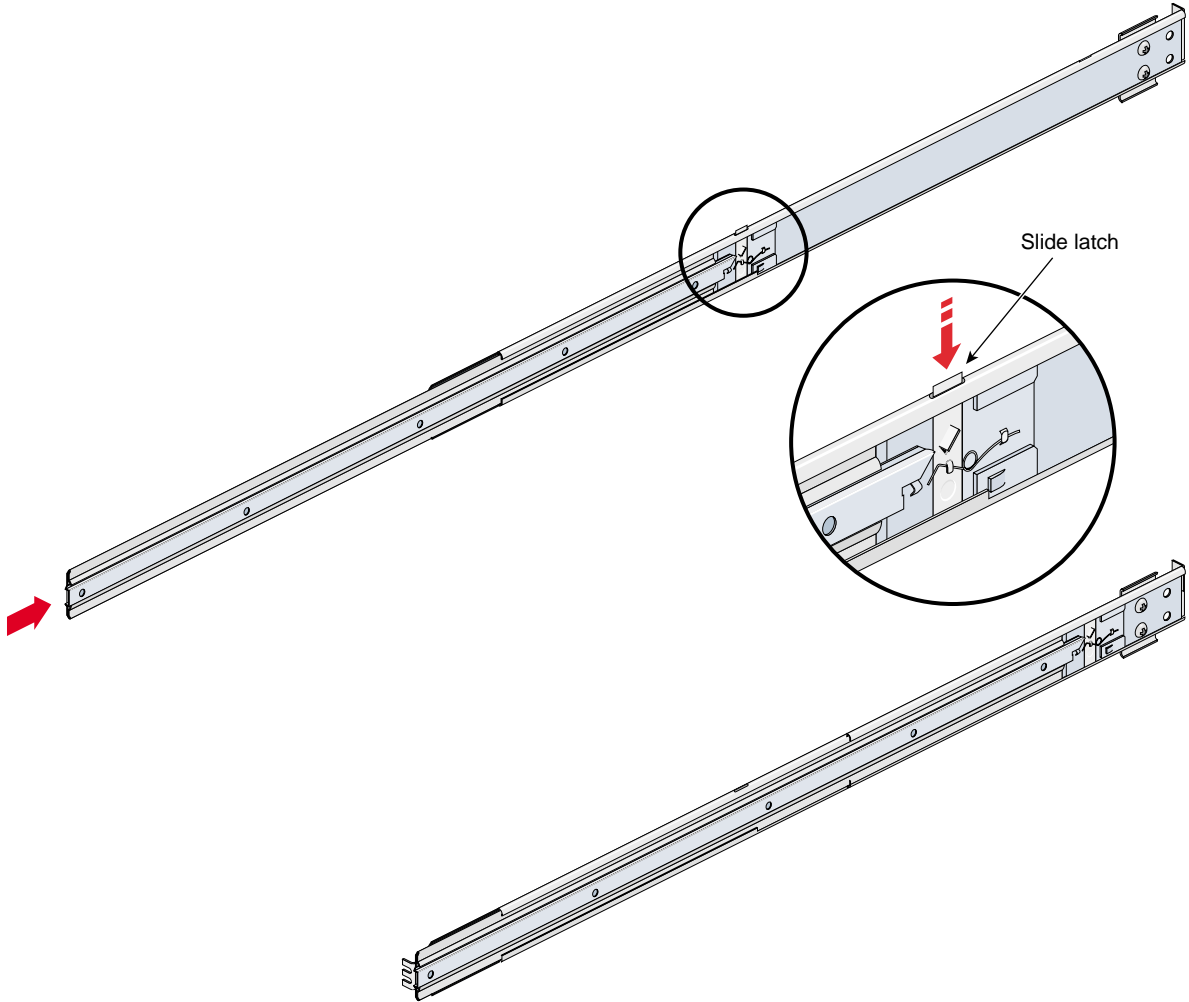


**Figure B-10** Releasing the Safety Latches



- 7. To slide the slide rails back into the rack, push down on the slide latches as shown in Figure B-11.

**Note:** Before you can reinstall a module into the rack, you must fully extend the slide rails from the rack until they lock into place.



**Figure B-11** Releasing the Slide Latches



## Safety and Regulatory Information

The following sections and illustrations present information that may be important to the operation of your rack-mountable Silicon Graphics® Tezro™ visual workstation.

This appendix provides safety information and regulatory specifications for your system in the following sections:

- “General Safety Information” on page 121
- “Manufacturer’s Regulatory Declarations” on page 123
- “System Numbers” on page 123
- “Manufacturer’s Declaration of Conformity” on page 124
- “Manufacturer’s Declaration of Conformity” on page 124
- “CE Notice” on page 124
- “Electromagnetic Emissions Notices” on page 124
- “Shielded Cables” on page 126
- “Electrostatic Discharge” on page 127
- “Lithium Battery Statement” on page 127
- “Laser Compliance Statements” on page 128

### General Safety Information

Read and follow these instructions carefully:

1. Follow all warnings and instructions marked on the product and noted in the documentation included with this product.
2. Unplug this product before cleaning. Do not use liquid cleaners or aerosol cleaners. Use a damp cloth for cleaning.
3. Do not use this product near water.

4. Do not place this product or components of this product on an unstable cart, stand, or table. The product may fall, causing serious damage to the product.
5. Slots and openings in the system are provided for ventilation. To ensure reliable operation of the product and to protect it from overheating, these openings must not be blocked or covered. This product should never be placed near or over a radiator or heat register, or in a built-in installation, unless proper ventilation is provided.
6. This product should be operated from the type of power indicated on the marking label. If you are not sure of the type of power available, consult your dealer or local power company.
7. Do not allow anything to rest on the power cord. Do not locate this product where persons will walk on the cord.
8. Never push objects of any kind into this product through cabinet slots as they may touch dangerous voltage points or short out parts that could result in a fire or electric shock. Never spill liquid of any kind on the product.
9. Do not attempt to service this product yourself except as noted in this guide. Opening or removing covers of node and switch internal components may expose you to dangerous voltage points or other risks. Refer all servicing to qualified service personnel.
10. Unplug this product from the wall outlet and refer servicing to qualified service personnel under the following conditions:
  - If the power cord or plug is damaged or frayed.
  - If liquid has been spilled into the product.
  - If the product has been exposed to rain or water.
  - If the product does not operate normally when the operating instructions are followed. Adjust only those controls that are covered by the operating instructions since improper adjustment of other controls may result in damage and will often require extensive work by a qualified technician to restore the product to normal condition.
  - If the product has been dropped or the cabinet has been damaged.
  - If the product exhibits a distinct change in performance, indicating a need for service.

11. Replace the lithium batteries on the PCI boards only with the same type or an equivalent type recommended by the manufacturer. Discard used batteries according to the manufacturer's instructions. There is a danger of explosion if the battery is incorrectly replaced.
12. Use only the proper type of power supply cord set (provided with the system) for this unit.
13. Do not attempt to move the system alone. Always use at least two people to move a rack.
14. Keep all system cables neatly organized in the cable management system. Loose cables are a tripping hazard that cause injury or damage the system.

## Manufacturer's Regulatory Declarations

The rack-mountable Silicon Graphics® Tezro™ visual workstation conforms to several national and international specifications and European Directives listed on the "Manufacturer's Declaration of Conformity." The CE insignia displayed on each device is an indication of conformity to the European requirements.



**Caution:** Each SGI system has several governmental and third-party approvals, licenses, and permits. Do not modify this product in any way that is not expressly approved by SGI. If you do, you may lose these approvals and your governmental agency authority to operate this device.

---

## System Numbers

The CMN (model) number for the system is shown on the system label on the unit. The series number is on the serial number label on the back of the system. You may need both the series number and CMN number to obtain the Manufacturer's Declaration of Conformity from SGI.

## Manufacturer's Declaration of Conformity

Look at the regulatory label on the system to determine your CMN (model) number. The serial number label determines your series number. You may need both of these numbers to identify your Manufacturer's Declaration of Conformity.

To obtain the Manufacturer's Declaration of Conformity from SGI, you must either provide the CMN number to your local SGI sales representative or contact the Technical Assistance Center at 1 800 800 4SGI.

## CE Notice

The "CE" symbol indicates compliance of the device to directives of the European Community. A "Declaration of Conformity" in accordance with the standards has been made and is available from SGI upon request.

## Electromagnetic Emissions Notices

This equipment has been tested and found to comply with the limits of a Class A device, pursuant to Part 15 of the FCC Rules. Operation is subject to the following two conditions:

- This device may not cause harmful interference.
- This device must accept any interference received, including interference that may cause undesired operation.

---

**Note:** These Class A limits are designed to provide reasonable protection against harmful interference when the equipment is operated in a commercial environment. This equipment generates, uses, and can radiate radio frequency energy and, if not installed and used in accordance with the instruction manual, may cause harmful interference to radio communications. Operation of this equipment in a residential area is likely to cause harmful interference, in which case users will be required to correct the interference at their own expense.

---

If this equipment does cause harmful interference to radio or television reception, which can be determined by turning the equipment off and on, try to correct the interference with one or more of the following measures:

- Reorient or relocate the receiving antenna.
- Increase the separation between the equipment and receiver.
- Connect the equipment to an outlet on a circuit different from that to which the receiver is connected.
- Consult the dealer or an experienced radio/TV technician for help.



**Caution:** Changes or modifications to the equipment not expressly approved by the party responsible for compliance could void the user's authority to operate the equipment.

This device also complies with Class A electromagnetic emissions limits of C.I.S.P.R. Publication 22, Limits and Methods of Measurement of Radio Interference Characteristics of Information Technology Equipment.

### Industry Canada Notice (Canada Only)

This Class A digital apparatus meets all requirements of the Canadian Interference-Causing Equipment Regulations.

Cet appareil numérique n'émet pas de perturbations radioélectriques dépassant les normes applicables aux appareils numériques de Classe A prescrites dans le Règlement sur les interférences radioélectriques établi par le Ministère des Communications du Canada.

### VCCI Notice (Japan Only)

この装置は、情報処理装置等電波障害自主規制協議会 (VCCI) の基準に基づくクラス A 情報技術装置です。この装置を家庭環境で使用すると電波妨害を引き起こすことがあります。この場合には使用者が適切な対策を講ずるよう要求されることがあります。

## Chinese Class A Regulatory Notice

### 警告使用者：

這是甲類的資訊產品，在居住的環境中使用時，可能會造成射頻干擾，在這種情況下，使用者會被要求採取某些適當的對策。

## Korean Class A Regulatory Notice

이 기기는 업무용으로 전자파적합등록을 한 기기이오니 판매자 또는 사용자는 이 점을 주의하시기 바라며 만약 잘못 판매 또는 구입하였을 때에는 가정용으로 교환하시기 바랍니다.

## Shielded Cables

SGI Onyx 350 graphics systems are FCC-compliant under test conditions that include the use of shielded cables between the system and its peripherals. Your system and any peripherals that you purchase from SGI have shielded cables. Shielded cables reduce the possibility of interference with radio, television, and other devices. If you use any cables that are not from SGI, ensure that they are shielded. Telephone cables do not require shielding.

Optional monitor cables that are supplied with your system use additional filtering molded into the cable jacket to reduce radio frequency interference. Always use the cable that is supplied with your system. If your monitor cable becomes damaged, obtain a replacement cable from SGI.



## Electrostatic Discharge

SGI designs and tests its products to be immune to the effects of electrostatic discharge (ESD). ESD is a source of electromagnetic interference and can cause problems that range from data errors and lockups to permanent component damage.

While you are operating the system, it is important that you keep all the covers and doors, including the plastics, in place. The shielded cables that came with the system and its peripherals should be installed correctly, with all thumbscrews fastened securely.

An ESD wrist strap may be included with some products, such as memory or PCI upgrades. Use the wrist strap when you install these upgrades to prevent the flow of static electricity; it is designed to protect your system from ESD damage.

## Lithium Battery Statement

Only qualified service personnel should replace a soldered lithium battery in the Onyx 350 visualization system.



---

**Warning:** Replace the battery with the same or equivalent type as recommended by the manufacturer, or the battery could explode. Discard used batteries according to the manufacturer's instructions.

---



---

**Warning:** Advarsel!: Lithiumbatteri - Eksplosionsfare ved fejlagtig håndtering. Udskiftning må kun ske med batteri af samme fabrikat og type. Léver det brugte batteri tilbage til leverandøren.

---



---

**Warning:** Advarsel: Eksplosjonsfare ved feilaktig skifte av batteri. Benytt samme batteritype eller en tilsvarende type anbefalt av apparatfabrikanten. Brukte batterier kasseres i henhold til fabrikantens instruksjoner.

---



---

**Warning: Varning:** Explosionsfara vid felaktigt batteribyte. Använd samma batterityp eller en ekvivalent typ som rekommenderas av apparattillverkaren. Kassera använt batteri enligt fabrikantens instruktion.

---



---

**Warning: Varoitus:** Pärasto voi räjähtää, jos se on virheellisesti asennettu. Vaihda paristo ainoastaan laitevalmistajan suosittelemaan tyyppiin. Hävitä käytetty paristo valmistajan ohjeiden mukaisesti.

---



---

**Warning: Vorsicht!:** Explosionsgefahr bei unsachgemäßen Austausch der Batterie. Ersatz nur durch denselben oder einen vom Hersteller empfohlenem ähnlichen Typ. Entsorgung gebrauchter Batterien nach Angaben des Herstellers.

---

## Laser Compliance Statements

The CD-ROM or DVD-ROM drive in this computer system is a Class 1 laser product. The drive's classification label is located on the unit.